

2

September 2024

Volume XXIV, Number 2



The Official Journal of the  
International Institute for the Advanced Studies of Psychotherapy and Applied Mental Health  
(IIAS of PAMH)

# JOURNAL OF EVIDENCE-BASED PSYCHOTHERAPIES

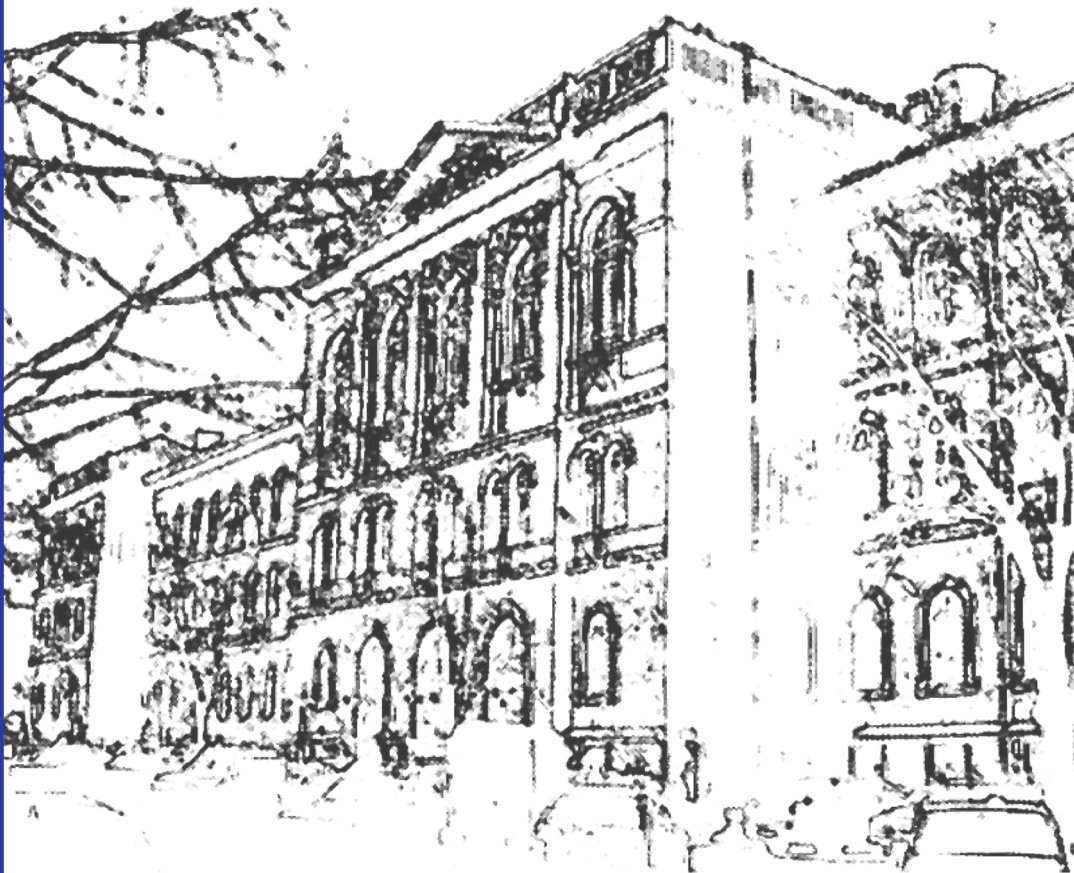

Presă Universitară Clujeană

**Journal of Evidence-Based Psychotherapies** is the successor of the Journal of Cognitive and Behavioral Psychotherapies (2001-2013) and is published biannually (in March and September) in one volume per year by the International Institute for the Advanced Studies of Psychotherapy and Applied Mental Health. The journal is devoted to the advancement of the clinical theory and practice of evidence-based psychotherapies (EBP) (e.g., evidence-based psychological assessments, evidence-based psychological treatments). The journal publishes original papers dealing with EBP and psychology, psychiatry, the medical and mental specialties, and allied areas of science. Submissions include (1) articles referring to clinical and experimental studies, discussions of theory, and systematic reviews for inclusion in Article Section, (2) articles referring to clinical discussions/developments for inclusion in the Clinical Forum Section, and (3) commentaries, letters to the editor, reviews and abstracts of books, tapes, and films, salient findings in EBP, and other information relevant to the journal's goal for inclusion in the Development and Resources Section. Finally, the journal seeks to publish special issues devoted to topics of particular interest, suggestions for which are welcomed by the Editor.

**Indexed in:** (1) **Abstracted:** Thomson ISI Web of Science/SSCI; SCOPUS; PsycINFO; and International Bibliography of Social Science; (2) **Full text:** EBSCO, ERIH+, and ProQuest

#### **CHIEF EDITOR:**

**Oana A. David**, Ph.D., Babeş-Bolyai University, Cluj-Napoca, Romania (2019-Present)

#### **ASSOCIATE EDITOR:**

**Irving Kirsch**, Ph.D., Harvard Medical School, USA/ Plymouth University, UK (2019-Present)

#### **FOUNDING EDITOR:**

**Daniel David**, Ph.D., Babeş-Bolyai University, Cluj-Napoca, Romania/Icahn School of Medicine at Mount Sinai, New York, USA

#### **PAST EDITORS:**

**Daniel David**, Ph.D., Babeş-Bolyai University, Cluj-Napoca, Romania

**Aurora Szentagotai Tătar**, Ph.D., Babeş-Bolyai University, Cluj-Napoca, Romania (2009-2013)

**Ioana-Alina Cristea**, Ph.D., Babeş-Bolyai University, Cluj-Napoca, Romania (2014-2019)

**Dr. David Barlow**,  
*Boston University, USA*

**Dr. Pim Cuijpers**,  
*VU University Amsterdam, The Netherlands*

**Dr. Frank Dattilio**,  
*Harvard Medical School, USA*

**Dr. Raymond DiGiuseppe**,  
*St. John's University, USA*

**Dr. Windy Dryden**,  
*London University, UK*

**Dr. Michael Eysenck**,  
*London University, UK*

**Dr. Michael First**,  
*Columbia University, USA*

**Dr. Joshua Fogel**,  
*City University of New York, USA*

**Dr. David Haaga**,  
*American University, USA*

**Dr. Steven Hayes**,  
*University of Nevada, USA*

**Dr. Phillip Kendall**,  
*Temple University, USA*

**Dr. Scott Lilienfeld**,  
*Emory University, USA*

**Dr. Elisabeth Loftus**,  
*University of California-Irvine, USA*

**Dr. Steven Jay Lynn**,  
*SUNY at Binghamton, USA*

**Dr. Richard McNally**,  
*Harvard University, USA*

**Dr. Donald Meichenbaum**,  
*Waterloo University, Canada*

**Dr. Michael Nash**,  
*Tennessee University, USA*

**Dr. Pietro Pietrini**,  
*University of Pisa, Italy*

**Dr. Ann Vernon**,  
*Albert Ellis Institute, USA*

**Dr. Jeffrey Young**,  
*Columbia University, USA*

#### **ACTING EDITORIAL BOARD**

**Daniel David**,  
*Babeş-Bolyai University, Romania/  
Icahn School of Medicine at Mount Sinai,  
New York, USA*

**Anca Dobrea**, Ph.D.,  
*Babeş-Bolyai University, Romania*

**Dan Lucian Dumitraşcu**, M.D., Ph.D.,  
*Iuliu Hatieganu University of Medicine  
and Pharmacy, Romania*

**Claudio Gentili**, M.D., Ph.D  
*Univeristy of Padua, Italy*

**Irina Holdevici**, Ph.D.,  
*Titu Maiorescu University, Romania*

**Viorel Lupu**, M.D., Ph.D.,  
*Iuliu Hatieganu University of Medicine  
and Pharmacy, Romania*

**Simona Stefan**, Ph.D.,  
*Babeş-Bolyai University, Romania*

**Aurora Szentagotai Tatar**, Ph.D.,  
*Babeş-Bolyai University, Romania*

**Bogdan Voinescu**, Ph.D.,  
*Babeş-Bolyai University, Romania*

#### **CONSULTING EDITORS**

**Richard Brown**, Ph.D.,  
*Institute of Neurology, London, UK*

**László Tringer**, Ph.D.,  
*Semmelweis University, Hungary*

**Guy Montgomery**, Ph.D.,  
*Icahn School of Medicine at Mount Sinai,  
New York, USA*

**Cristina Pojoga**, M.D.,  
*Babeş-Bolyai University, Romania*

**Simona Popa**, Ph.D.,  
*Oradea University, Romania*

**Agnieszka Popiel**, M.D.,  
*Medical University of Warsaw, Poland*

**Jan Prasko**, M.D., Ph.D.,  
*3rd Medical Faculty, Charles  
University, Czech Republic*

**Adrian Rosan**, Ph.D.,  
*Babeş-Bolyai University, Romania*

**Dan Octavian Rusu**, Ph.D.,  
*Babeş-Bolyai University, Romania*

**Mihaela Stănculete**, M.D.,  
*Adult Clinical Hospital, Romania*

**Mehmet Z. Sungur**, M.D., Ph.D.,  
*Medical School of  
Marmara University, Turkey*

**Jezdimir Zdravkovic**, Ph.D.,  
*University of Nis, Serbia*

#### **Statistical Consultant**

**Silviu Matu**, Ph.D.,  
*Babeş-Bolyai University, Romania*

#### **Scientific Secretary**

**Vasile Sîrbu**, MA  
*Babeş-Bolyai University, Romania*

#### **Journal's Website Administrator**

**Răzvan Antonescu**,  
*Cluj-Napoca, Romania*

CONTENTS

ARTICLES SECTION

- Temporal Dynamics of Stress, Affect, and Abdominal Pain in IBS: Insights from a Clinical Sample..... 1**  
 SANDA PLETIKOSIĆ TONČIĆ, MARKO TONČIĆ, TAJANA JANČEC
- Evaluation of a Schema Therapy-Based Prevention Group Program for Children and Their Parents ..... 23**  
 ROZA LAIOUS, EVANGELIA P. GALANAKI, AIKATERINI AGGELI, CHARA TZAVARA, EFTYCHIA ARGALIA, DARIA BAKOURINI, VASSILIKI KOUTRAFOURI, AIKATERINI MARINI, AND IOANNA SINTILA
- Psychometric Properties of the Italian Version of the Interpersonal Sensitivity Measure (IPSM) ..... 53**  
 COMPARE LISA, CANSU ALSANCAK-AKBULUT, GIOVANNI TUMMINARO, MARTINA SMORTI, OLIVIA BERNINI, FRANCESCA RAVAGLI, CARMEN BERROCAL MONTIEL
- The Effectiveness of Compassionate Mind Training (CMT) for Undergraduate Students..... 69**  
 TÜNDE PÓKA AND ANDREA BARTA
- Impaired Emotional Processing in Major Depressive Disorder. Accuracy versus Processing Speed ..... 105**  
 BOGDAN NEMEŞ, HORIA G. COMAN, DANA C. HERȚA, RALUCA N. TRIFU, DOINA M. C. COZMAN
- Loneliness and Cognitive Vulnerability Factors: A Systematic Review Focused on Maladaptive Cognitions ..... 117**  
 LIA-ECATERINA OLTEAN, MIRUNA-GABRIELA CANACHE, ANDREI PATRICHI, RALUCA IOANA RÎMBU, DARIA ȘINTOMA, ANDREI C. MIU, AURORA SZENTÁGOTAI-TĂTAR
- Adaptation and Validation of the Meteoropathy Questionnaire to the Turkish Sample..... 139**  
 CENNET YASTIBAŞ-KAÇAR, İMRAN GÖKÇEN YILMAZ-KARAMAN, MARIANNA MAZZA
- Loneliness and Mental Health During the First Covid-19 Lockdown in Romania..... 155**  
 A. HOPULELE-PETRI, S.A. MATU, O. CAPATINA, M. MANEA
- Potential Mechanisms Underlying Reappraisal Strategies: An Exploratory Study .. 177**  
 KAROL J. WILD, BIANCA MACAVEI, ADRIAN N. OPRE
- Psychometric Properties and Factor Structure of the Disgust Scale-Revised (DS-R) for the Romanian population..... 201**  
 SIMONA A. PASCAL

The International Institute for the Advanced Studies of Psychotherapy and Applied Mental Health (IIAS of PAMH) is a research Institute of the Babes-Bolyai University (BBU), located in Cluj-Napoca, Romania. Babes-Bolyai University is one of the oldest, most prestigious, and influential academic settings in Romania and in the Eastern-Central Europe (<http://www.ubbcluj.ro>). It has been almost four centuries since the beginnings of this university of Cluj-Napoca. The first project to set up a higher education institution in Cluj-Napoca was recorded in 1565, and in 1581 it was set up an academic college, organized and run by Jesuits. Since then, Babes-Bolyai University has become a modern institution which acquired a remarkable fame by its long-time achievements at national and international level. The Institute will invite as affiliates/partners prestigious organizations involved in the development of psychotherapy and applied mental health interventions. IIAS of PAMH aims to promote advanced study and scholarship in applied mental health by research.

The Faculty of IIAS of PAMH will have strategic and consultative responsibilities. It is composed of prestigious professionals in the area of Psychotherapy and Applied Mental Health Interventions:

Dr. David Barlow Boston University, USA  
Dr. Pim Cuijpers, VU University Amsterdam,  
The Netherlands  
Dr. Frank Dattilio, Harvard Medical School, USA  
Dr. Raymond DiGiuseppe, St. John's University, USA  
Dr. Windy Dryden, London University, UK  
Dr. Michael Eysenck, London University, UK  
Dr. Michael First, Columbia University, USA  
Dr. Joshua Fogel, City University of New York, USA  
Dr. David Haaga, American University, USA  
Dr. Steven Hayes, University of Nevada, USA

Dr. Phillip Kendal, Temple University, USA  
Dr. Scott Lilienfeld, Emory University, USA  
Dr. Elisabeth Loftus, University of California-Irvine, USA  
Dr. Steven Jay Lynn, SUNY at Binghamton, USA  
Dr. Richard McNally, Harvard University, USA  
Dr. Donald Meichenbaum, Waterloo University, Canada  
Dr. Michael Nash, Tennessee University, USA  
Pietro Pietrini, M.D., Ph.D., University of Pisa, Italy  
Dr. Ann Vernon, Albert Ellis Institute, USA  
Dr. Jeffrey Young, Columbia University, USA

Specific information and more detailed information about IIAS of PAMH may be obtained by visiting our website at: <http://www.psychotherapy.ro> or by emailing us to [internationalinstitute@psychology.ro](mailto:internationalinstitute@psychology.ro)

ISSN: 2360 – **0853**  
ISSN-L: 2360 – **0853**

© 2024, The Editors.

Universitatea Babeş-Bolyai  
Presa Universitară Clujeană  
Director: Codruța Săcelean  
Str. Hasdeu nr. 51  
400371 Cluj-Napoca, România  
Tel./Fax: (+40)-264-597.401  
E-mail: [editura@ubbcluj.ro](mailto:editura@ubbcluj.ro)  
<http://www.editura.ubbcluj.ro>

---

## TEMPORAL DYNAMICS OF STRESS, AFFECT, AND ABDOMINAL PAIN IN IBS: INSIGHTS FROM A CLINICAL SAMPLE

---

*Sanda Pletikosić Tončić<sup>1\*</sup>, Marko Tončić<sup>2</sup>, and Tajana Jančec<sup>3</sup>*

---

<sup>1</sup> University of Rijeka, Faculty of Humanities and Social Sciences, Department of Psychology, <https://orcid.org/0000-0002-9152-0380>

<sup>2</sup> University of Rijeka, Faculty of Humanities and Social Sciences, Department of Psychology, <https://orcid.org/0000-0002-0898-3115>

<sup>3</sup> Varaždin County Public Health Institute

---

### Abstract

Irritable bowel syndrome (IBS) has a complex aetiology involving biological and psychological alterations. Among others, stress seems to be a relevant factor for IBS symptom onset and exacerbation. Affective changes can be related to symptom severity and stressful experiences and may be valuable for therapeutic purposes. The aim of this study was to examine temporal dynamics of affect, stress, and symptom severity (specifically abdominal pain) in a sample of IBS patients.

Thirty-two outpatients kept a diary with a set of short questionnaires (Affect scale, Symptom severity scale, and Daily stress measure) once a day, in the evening, for 14 days.

Abdominal pain was modeled as a function of between-person, concurrent and lagged within-person effect of stress and affect controlling for autoregressive pain effects. Positive and negative affect exhibited concurrent effects on abdominal pain while stress did not. Daily variation in positive affect was associated with a decrease in pain while the opposite was true for negative affect. Positive and negative affect models explained over 40% of the variation in daily abdominal pain. Even though the models had a good fit, the amount of variance explained by positive and negative affect alone was relatively small (~7%) with high interindividual heterogeneity.

It seems that day-to-day stress variations do not have a direct impact on abdominal pain, while affective dynamics appear closely related to pain variations.

**Keywords:** Irritable bowel syndrome, Affect, Symptom severity, Daily stress.

---

\* Correspondence concerning this article should be addressed sent to Sanda Pletikosić Tončić, Faculty of Humanities and Social Sciences, Department of Psychology, Sveučilišna avenija 4, 51000 Rijeka, Croatia.

Email: [spletikosic@ffri.uniri.hr](mailto:spletikosic@ffri.uniri.hr)

Irritable bowel syndrome (IBS) is one of the most common functional gastrointestinal disorders, characterized by changes in stool frequency and/or appearance accompanied by pain and discomfort (Lacy et al., 2016). Most IBS patients are women (M:F=1:2) and the prevalence rates in developed countries vary from 4.6% to 9.0% (depending on the criteria used) (Palsson et al., 2020). Although IBS has been in the focus of research for several decades, some aspects of the disorder remain unknown.

The predominating theoretical framework used to describe IBS and its aetiology is the biopsychosocial model of health and disease (Van Oudenhove et al., 2016). In line with the model, IBS is the result of life-long interactions of genetically determined traits (eg. personality traits, hypothalamic-pituitary-adrenal (HPA) axis reactivity) and environmental factors (exposure to pathogens, early adverse events) (Hauser et al., 2014). This interaction results in short-term and/or long-term changes in brain-gut communication, which are enabled via several mechanisms (central top-down connections, HPA axis, autonomic system, immune system) (Kennedy et al., 2012). Genes and early experiences shape specific brain-gut phenotypes which express different responses to external influences in adulthood (Mayer et al., 2023). Research shows that this brain-gut-microbiota axis has bidirectional connections, meaning that a change in any component of the axis can lead to global dysregulation and symptoms such as those in IBS (Martin et al., 2018).

Although much remains to be elucidated regarding the aetiology of IBS, findings have provided relatively consistent data regarding some of its aspects. For example, most models attempting to describe the aetiology of IBS and maintenance of its symptoms include some aspects of stress (Mayer et al., 2023, Qin et al., 2014; Van Oudenhove et al., 2016). Some focus on stressful life events, others include stress related personality traits (neuroticism) or states (anxiety). Early life stress is also viewed as a significant factor for the development of the brain-gut axis, and thereby IBS. And finally, the impact of everyday stressors on symptom exacerbation is considered, along with coping strategies, cognitions and behaviours IBS patients use to deal with these stressors (Hauser et al., 2014; Kennedy et al., 2012; Martin et al., 2018; Mayer et al., 2023).

Research indicates that stress most probably does have an impact on symptoms via various mechanisms within the brain-gut (-microbiota) axis (Martin et al., 2018). Different aspects and measures of stress have been related to IBS patients' functioning. Even though there seem to be no differences between IBS patients and inflammatory bowel disease (IBD) patients, or healthy controls on reports of major life events (Blanchard et al., 2008; Kovács et al., 2007; Levy et al., 1997), it seems that IBS patients report a greater number of negative stressful events (Halpert et al., 2005; Parker et al., 2019; Van Oudenhove et al., 2016) and a lower number of positive events (Drossman et al., 1988). IBS patients also show a higher reactivity to stress (Mayer et al., 2001), report higher levels of perceived stress

(Weaver et al., 2018) and experience elevated levels of daily stress compared to healthy controls (Blanchard et al., 2008; Hertig et al., 2007).

There are multiple mechanisms of stress action, possibly involving HPA axis dysregulation - reflected in altered cortisol levels (Chang et al., 2009; Kennedy et al., 2014), autonomic dysfunction (Mazurak et al., 2012; Van Oudenhove et al., 2016), maladaptive coping strategies, and altered cognitions and behaviours (Lackner et al., 2022).

Research shows that even prenatal stress in mothers has an impact on the development of the brain-gut-microbiota axis in infants. Infants of mothers reporting higher stress and anxiety had reduced diversity of microbiota species as well as lower quantity of beneficial microbiota species. Animal models have shown that prenatal stress in the mother can lead to visceral hypersensitivity in the offspring (Zhou et al., 2023). Emotional abuse, physical punishment and general trauma in childhood are associated with a greater risk for developing IBS later in life, as well as a variety of other medical conditions (Rahal et al., 2020), including anxiety and depression. This is one of several overlapping characteristics of IBS patients and people suffering from affective disorders.

IBS patients have elevated levels of anxiety and depression compared to healthy persons (Lee et al., 2017) and compared to patients with similar diseases with clear organic pathology (Henningsen et al., 2003). They also tend to have comorbid psychiatric diagnoses, such as generalized anxiety disorder or major depressive disorder (Gros et al., 2009; Henningsen et al., 2003), however their anxiety and depression levels are lower than those found in psychiatric populations (Creed et al., 2006; Hood et al., 2008). A recent meta-analysis showed that IBS patients have three-fold increased chances of having anxiety or depression, compared to healthy controls (Zamani et al., 2019).

The possible impact of anxiety and depression on IBS is diverse. For example, anxiety and depression could mediate the relationship between stress and GI symptoms, which was proposed by Hertig et al. (2007) when they demonstrated that this relationship becomes non-significant after controlling for levels of anxiety and depression. Furthermore, anxiety could lead to changes in cognitive interpretations of GI sensations, which could cause an attentional shift towards bowel sensations. Focusing attention on the abdomen in combination with worry and anxiety could exacerbate symptoms, reinforcing anxiety and thus closing the vicious circle (Deary et al., 2007). Compared to those without, IBS patients with anxiety and depression have altered ANS function, higher somatic symptoms, visceral hypersensitivity and higher visceral (GI-specific) anxiety (Midenfjord et al., 2019).

IBS patients usually report daily stressful events as triggers of symptom exacerbation, however the symptoms themselves can also act as stressors (Qin et al., 2014). Most research on daily stress and symptoms provides evidence for such a reciprocal relationship. There seems to be some support for concurrent, and to a

lesser degree, delayed effects of stress on symptom severity and vice versa (Pletikosić et al., 2016). Results obtained by Levy et al. (1997) show a positive relationship between same-day stress and symptoms, but also an increase in these correlations when multiple-day data are averaged. Several other studies (Blanchard et al., 2008; Chan et al., 2019; Pletikosić et al., 2016) also reported delayed effects of daily stress on symptoms (and vice versa), but some were unable to replicate those results and found only concurrent effects (Vork et al., 2020). The inconsistencies in obtained results could be attributed to variations in methodology, with some researchers using weekly data (Blanchard et al., 2008), others using end-of-day diaries (Dancey et al., 1998; Levy et al., 1997) and more recent studies (Chan et al., 2019; Vork et al., 2020) employing experience sampling methodology (ESM). In some studies, different patterns of the stress-symptom relationship are reported for subsets of patients (Levy et al., 1997; Pletikosić et al., 2016). Most of them reported only concurrent effects, while others (Hertig et al., 2007; Suls et al., 1994) found no significant relationship between daily stress and symptoms.

Most studies on stress and mood in IBS use retrospective patient reports, which limits the interpretation of their relationship with symptoms and quality of life. Temporal dynamics of mood have been the focus of research only recently. Research shows that low psychological well-being is related to unstable, more variable, and inert emotions (Houben et al., 2015). Findings suggest that compared to healthy controls, anxious individuals experience greater variability and instability of anxious mood following negative events (Lamers et al., 2018). Compared to patients in remission and healthy controls, patients currently experiencing anxiety or depression have the highest affect instability in positive and negative affect (Schoevers et al., 2021). Considering that anxiety is a characteristic of IBS patients, it is reasonable to wonder whether these altered dynamical patterns are also present in IBS patients.

Disentangling the stress-mood-symptom relationship could be relevant for psychological interventions. However, to our knowledge, there is a single study exploring this relationship in IBS patients (Chan et al., 2019), which has shown that an increase in daily stress predicts a subsequent decrease in symptoms, while symptom severity predicts an increase in negative affect and daily stress. The counterintuitive relationship between stress and symptom severity was also found in a subset of patients in one of our previous studies (Pletikosić et al., 2016), however Vork et al. (2020) only reported significant concurrent associations between stress and symptoms. This study aims to expand and reexamine the findings by Chan et al. (2019) in several ways. First, we included patients with all predominating subtypes, not only IBS-D. Second, in order to avoid missing data which is typical for momentary assessment and leads to uneven intervals between consecutive measurement points, we chose a larger time interval between measurements, ensuring that participants have enough time and the proper surroundings to complete

the diary scales. Finally, we used validated questionnaires for measuring positive and negative mood in order to increase the validity of the measurement. Accordingly, the goal of this preliminary report was to examine the effects of mood and stress on abdominal pain in a small sample of IBS patients.

## Method

### *Participants*

In this study, we recruited outpatients from two medical centres: the Clinical Hospital Center in Rijeka (Department of Gastroenterology) and Clinical Hospital Center “Sveti Duh” in Zagreb (Referral centre for functional gastrointestinal diseases). A total of 40 patients diagnosed with IBS (Rome III) participated in the study, however due to incomplete diary data ( $n=4$ ), psychiatric comorbidities ( $n=2$ ), and no variability in one of the measured variables ( $n=2$ ) analyses were performed on data obtained from 32 participants (81.5% female). Their age range was 21 to 80 ( $M=50,76$ ;  $SD=14,51$ ), most of them were married (55,3%), currently employed (55,3%) and had a high school (50,00%) or University education (36,8%).

### *Measures*

#### *Affect scale*

Affect was measured using an abbreviated version of the Mood scale (Kardum et al., 1992) which has 15 items and measures two factors (positive and negative affect). Positive affect (PA) contains the following adjectives: benevolent, lively, active, happy, tolerant, cheerful, satisfied. The negative affect factor comprises the following: melancholy, fearful, rejected, isolated, scared, irritable, sad, angry. The participants’ task was to mark the degree in which they feel a certain way (e.g. isolated) from zero (not at all) to four (I feel that way completely). By calculating the average response for items of each subscale (PA and NA), two final scores are obtained.

#### *Symptom severity scale*

The Symptom severity scale was constructed based on the Gastrointestinal Symptom Diary (Blanchard, 2001). The scale has eight symptoms (diarrhoea, constipation, abdominal pain, abdominal tenderness, nausea, belching, bloating and flatulence), and the participants’ task is to rate the severity of each symptom from zero (absent) to four (debilitating). In this paper, only data for abdominal pain was used.

*Daily stress*

Daily stress was measured using a single-item measure, modified from Larsson et al. (2015) (sleep disturbances were left out of the description and the time frame was modified to suit the needs of the study): “Stress means a situation when a person feels tense, restless, nervous, or anxious. Have you experienced such a situation today? Mark how stressful the situation was (0 – I haven’t experienced such a situation today; 4 – extremely stressful).

*Procedure*

The study was conducted from February to April of 2018, in the Clinical Hospital Center in Rijeka and the Clinical Hospital Center “Sveti Duh” in Zagreb. Participants took part in a larger study and completed a series of questionnaires and computerized tasks during two sessions. Between those sessions, participants kept diaries once a day, in the evening, for a total of 14 days. Measurements were taken once a day as a means of capturing day-to-day variations, but also minimizing the burden of continuous two-week measurements on participants. This paper focuses solely on the prospective diary data. Participants were provided with booklets containing the Symptom severity scale, Affect scale and Daily stress. Prior to the beginning of the two-week monitoring period, participants were individually given detailed instructions. Participants were explicitly instructed not to retrospectively input data if they missed a measurement point. They were also provided with a phone number and an email address where they could reach out at any time with questions or other inquiries.

*Analytic approach*

The main goal was to estimate the relationship of daily stress and affect with abdominal pain perception, as well as their temporal dependency. Because of the nested structure of the data (measurement points nested within individuals/participants), analyses were made within a hierarchical linear modeling approach using the ‘lme4’ package (Bates et al., 2015) for the R statistical environment (R Core Team, 2020). With this approach we can estimate the variance that can be attributed to participant diversity, and at the same time we can estimate the effects of specific ratings (stress and affect) at each measurement point.

Due to a low subject number, separate models were fitted for daily stress, positive and negative affect respectively. To separate between-person and within-person effects of daily stress and affect, daily PA, NA and stress ratings were decomposed into individual level mean (i.e. between-person effects) and by-subjects deviation from the specific individual level mean (i.e. within-person effects) (Little et al., 2006). Temporal dependency of daily stress, affect and abdominal pain perception, was tested using lagged terms. To control for possible pain perseveration,

an autoregressive abdominal pain term was included in all models. The fitted models were compared to the unconditional model containing only random (by-subject) intercepts via likelihood ratio test while the estimates' confidence intervals were calculated using a bootstrap procedure with 5000 samples. To help compare model estimates with usual regression results, standardized parameters, conditional and marginal  $R^2$  estimates (Nakagawa et al., 2017) were calculated.

### Sample size estimation

The sample size was estimated by means of power analysis corrected for multilevel data (Cohen, 1992; Hox, 2010). For an approximate effect size of trait (0.50) (Blanchard et al., 2008; Pletikosić & Tkalčić, 2016) and state (0.30) (Dancey et al., 1998; Vork et al., 2020), a power of 0.80 and a two-tailed alpha of .05, the minimum  $N$  was 28.25 at level 2 (trait) and 84.07 at level 1 (state). After level 1  $N$  was corrected for nestedness (14 ratings per participant and an  $ICC$  of 0.30), the resulting number of ratings (level 1  $N$ ) was 411.60. The sample used in the study consisted of  $N=32$  (level 2) and  $N=448$  (level 1).

## Results

Correlations were estimated using hierarchical linear modeling. Reliabilities for all measures were estimated with variance components for the unconditional model extracted via hierarchical linear modeling as suggested by Revelle and Wilt (2017). Descriptives, correlations and estimated person-level reliabilities are presented in Table 1.

**Table 1.** Between- and Within-Person Descriptives for Daily Stress, Positive and Negative Affect and Abdominal Pain.

Variable	Between-person			$r$				Within-person	
	RkRN	Mean	$SD$	1	2	3	4	Mean	$SD$
1. PA	.91	2.43	0.45	-	-.51**	-.39*	-.20*	0.00	0.49
2. NA	.83	0.83	0.47	-.33*	-	.45**	.17*	0.00	0.47
3. Daily stress	.79	1.06	0.55	.16*	.55**	-	.04	0.00	0.87
4. AP severity	.91	1.16	0.79	.01	.24*	.18*	-	0.00	0.76

PA: positive affect; NA: negative affect; AP: abdominal pain; RkRN: Reliability over k Random Nested days, reliability was averaged over time; Correlations below the diagonal are between individuals, and correlations above the diagonal are within-individuals. \*  $p < .05$ ; \*\*  $p < .01$

Pain severity was characterized by relatively low intensity and high variability between and within-individuals. Between-person averages of daily stress and negative affect were relatively low as well, while the within-person variability

of daily stress was quite pronounced (high *SD*). Despite the high within-person variability, daily stress and abdominal pain severity were not significantly related within-person. Positive affect showed a higher within-person than between-person correlation with other measures.

To predict abdominal pain severity, separate models were fitted and their global fit indicators, as well as comparisons with an unconditional null model, are presented in Table 2.

**Table 2.** Fit Indices of The Tested Models (Stress; PA and NA) and Significance Testing Compared to the Null-Model

Models	<i>df</i>	<i>AIC</i>	<i>BIC</i>	log-likelihood	$\chi^2$ (vs. null-model)	<i>df</i> ( $\chi^2$ )	<i>p</i>
Null-model	3	1143.30	1155.61	-568.65			
Stress model	8	787.18	817.13	-385.59	366.12	5	<.001
PA model	8	873.79	904.70	-428.89	279.51	5	<.001
NA model	8	868.12	898.94	-426.06	285.18	5	<.001

The inclusion of abdominal pain autoregressive term and respective predictors (stress, PA, NA, respectively) significantly increased the model fit above mere pain inter-individual differences. The parameters of specific models are presented in Table 3.

All models exhibited a fair fit (Conditional  $R^2 < 0.40$ ) even though the estimated effect of fixed parameters was relatively low (Marginal  $R^2 \sim 0.07$ ). Autoregressive pain effects were significant with an estimated effect of 0.17 (a one-point increase in pain above the person mean has a carry-over effect of 0.17 to the next day). Although the stress model was significant as a whole, no significant stress-related estimates were found and most of the model fit is to be attributed to autoregressive pain effects. It must be noted though, that the between-person stress estimates were close to significance suggesting that it might be possible that individuals with higher mean stress levels have higher pain levels as well. Positive affect showed a significant concurrent within-person effect with no significant lagged effects. An increase in daily PA is associated with a -0.31 decrease in abdominal pain severity. The between-person estimates were small (close to zero). At the same time, negative affect exhibited a significant positive concurrent within-person effect on abdominal pain severity (0.27) with no significant lagged effects. Similar to the stress model, the between-person estimates were marginally higher than other NA estimates ( $p \sim 0.10$ ) potentially suggesting a possible between-person effect on abdominal pain.

**Table 3.** Estimated Coefficients, Bootstrap 95% Confidence Intervals, and Variance Components of Stress, Positive and Negative Affect Models

	Estimate	S.E.	Bootstrap 95% C.I.	Std. Estimate	t	variance	
Stress	Intercept	0.58	0.27	0.05 : 1.13		2.13	0.3677
	Autoregressive term	0.15	0.06	0.04 : 0.25	0.15	2.65	
	Between-person effects	0.39	0.22	-0.05 : 0.84	0.19	1.74	
	Within-person effects	0.04	0.05	-0.06 : 0.14	0.03	0.73	
	Lagged effects (-1)	-0.05	0.05	-0.16 : 0.05	-0.04	-1.09	
	Lagged effects (+1)	0.03	0.05	-0.06 : 0.13	0.03	0.66	
	Residual						0.5692
				Conditional R <sup>2</sup>		0.44	
				Marginal R <sup>2</sup>		0.08	
	Estimate	S.E.	Bootstrap 95% C.I.	Std. Estimate	t	variance	
Positive affect	Intercept	0.93	0.66	-0.37 : 2.24		1.41	0.4120
	Autoregressive term	0.17	0.05	0.06 : 0.28	0.17	3.25	
	Between-person effects	0.03	0.27	-0.50 : 0.54	0.01	0.10	
	Within-person effects	-0.31	0.08	-0.46 : -0.14	-0.14	-3.80	
	Lagged effects (-1)	0.04	0.08	-0.12 : 0.20	0.02	0.52	
	Lagged effects (+1)	0.01	0.08	-0.15 : 0.17	0.01	0.09	
	Residual						0.5475
				Conditional R <sup>2</sup>		0.46	
				Marginal R <sup>2</sup>		0.06	
	Estimate	S.E.	Bootstrap 95% C.I.	Std. Estimate	t	variance	
Negative affect	Intercept	0.75	0.24	0.27 : 1.22		3.08	0.3904
	Autoregressive term	0.16	0.05	0.06 : 0.27	0.16	3.05	
	Between-person effects	0.32	0.25	-0.17 : 0.80	0.14	1.26	
	Within-person effects	0.27	0.09	0.09 : 0.45	0.11	2.93	
	Lagged effects (-1)	-0.10	0.09	-0.28 : 0.09	-0.04	-1.04	
	Lagged effects (+1)	-0.01	0.09	-0.19 : 0.17	-0.01	-0.14	
	Residual						0.5564
				Conditional R <sup>2</sup>		0.46	
				Marginal R <sup>2</sup>		0.07	

## **Discussion**

This study examined the concurrent and delayed effects of affect and stress on abdominal pain in IBS patients. The obtained results show that concurrent levels of positive and negative mood are related to pain intensity. Positive mood was negatively related to concurrent abdominal pain, while a positive association was found for negative mood. Those concurrent effects of positive and negative affect were relatively balanced in intensity. The mentioned results suggest that the impact of positive and negative affect on abdominal pain on a day-to-day basis is similarly important. No significant association was found between daily stress and abdominal pain, neither for concurrent nor for delayed effects. As already mentioned in the Results section, the between-person effects of stress on abdominal pain were higher than the other stress related model parameters and close to formally significant, suggesting a possible relation of average stress levels with interindividual differences in abdominal pain (people with higher stress levels tend to experience more abdominal pain).

To our knowledge, repeated assessment of positive and negative affect has previously been reported only in one prospective study in IBS patients (Chan et al., 2019), making this the second study exploring such temporal dynamics of affect. We obtained several noteworthy findings. First, we found significant negative correlations between concurrent positive and negative affect, which was also described by Chan et al. (2019). This has previously been reported for healthy subjects (Diener et al., 1984), especially in the context of momentary assessment. Even when measured retrospectively, positive and negative affect are increasingly more related as the respective time frames become shorter. This could imply that even though positive and negative affect can be unrelated on a general level, it is unlikely one can feel both positive and negative affect at the same moment, especially at a high intensity (Diener et al., 1984).

Our data also indicated that negative and positive affect were significantly associated with abdominal pain, similar to results provided by Chan et al. (2019). Higher negative and lower positive affect were related to higher abdominal pain. Unlike Chan et al. (2019) who reported that pain and other GI symptoms were related to affective states in subsequent time points, we found significant concurrent effects, while delayed effects were not significant. This is probably due to the fact that Chan et al. (2019) used momentary assessment and their time points were, at most, separated by several hours, while ours were measured at daily intervals. Taken together, these findings suggest that the association between mood and pain is temporally limited to several hours, which is reflected in significant within-day effects, but not in delayed cross-correlations of end-of day diary scores. Regardless

of the temporal relationship, this shows that abdominal pain has a significant impact on daily psychological functioning and wellbeing of IBS patients.

In the present study, significant concurrent associations of daily stress and mood were obtained. More precisely, as daily stress levels rose, IBS patients reported lower positive and higher negative mood. This was true for intraindividual as well as interindividual effects. Similar results were reported by the abovementioned study by Chan et al. (2019), however they only presented data for stress and negative mood. Findings obtained using end-of day diary data on healthy persons revealed the same associations for positive and negative affect with stress (Richardson, 2017). The correlation between stress and negative affect is well known and is especially pronounced in persons with high trait neuroticism, as their reactions to negative and stressful events tend to be more intense and aversive (Mroczek et al., 2004). It is well established that IBS patients represent one such group of people with high trait neuroticism (Hauser et al., 2014).

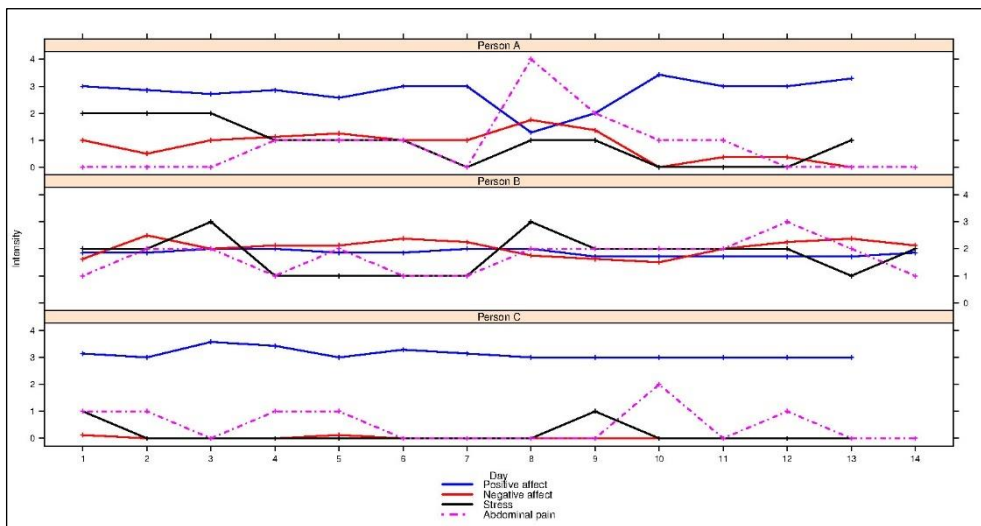

**Figure 1.** Positive and Negative Affect, Stress, and Abdominal Pain Severity on 14 Days for Three IBS Patients.

Note: Patient A shows a relatively high variability and a visible association of affect, stress, and abdominal pain. Patient B shows a lower variability with lower and less clear associations of affect, stress, and abdominal pain. Patient C exhibits a low variability with an almost non-existent correlation of affect, stress, and abdominal pain.

The results of the present study do not support a significant relationship between daily stress and abdominal pain. We found no significant effects of stress on pain, neither concurrent nor delayed ones. This contrasts with findings by Chan

et al. (2019), who reported significant delayed effects, and Vork et al. (2020), who reported significant concurrent effects of stress on pain. In both of those studies, data were measured using momentary assessment, unlike our data which was reported retrospectively at the end of the day. It could be argued that stress and pain have an in-the-moment association, or a temporally limited association which is no longer significant when dealing with assessments for the experiences of an entire day. Mujagic et al. (2015) have shown that end-of-day diary abdominal pain scores are higher than scores obtained by momentary assessment, which could alternatively be the cause of these differing results. Perhaps the tendency of patients to overestimate pain intensity (which is a characteristic of persons with high neuroticism) leads to a distortion of the stress-symptom relationship, which is not the case for momentary assessment. Some previous studies which also used end-of-day diaries have reported significant associations of stress and pain in IBS patients. One study found correlations between symptoms and a combination of same-day and previous-day stress scores (Levy et al., 1997) and another found correlations between symptoms and a combination of stress scores from the preceding 4 days (Dancey et al., 1998). Both studies resorted to aggregated measures of stress, used small samples of IBS patients ( $n=26$  and  $n=31$ ) and reported significant associations in only 38% (Levy et al., 1997) and 43% (Dancey et al., 1998) of their participants. Similarly, Hertig et al. (2007) reported significant stress-symptom associations in around 30% of their sample ( $n=181$ ), however these associations were substantially reduced after controlling for daily anxiety and depression. Their interpretation was that this relationship may be mediated by psychological distress, which we didn't measure directly in the present study, but it could be reflected in high negative and low positive affect. Thus, even though we did not find significant stress-symptom correlations, we did find significant stress-mood associations as well as mood-pain correlations, which supports the possible mediating effect of psychological distress in the stress-symptom relationship. Another marginally non-significant effect is worth mentioning, especially considering the limited size of our sample – the average bi-weekly stress level reflected in interindividual variations of stress was marginally related to abdominal pain ( $p=0.18$ ). This average of daily assessments could be viewed as a measure of chronic stress, which would imply that IBS daily symptoms are most dominantly impacted by long-term or chronic exposure to daily stress.

In line with our findings, Suls et al. (1994) reported no significant effects of daily stress on symptoms after controlling for autocorrelation of symptoms, but they found significant stress-symptom correlations of weekly aggregates. Similarly, Blanchard et al. (2008) also analysed weekly data and concluded that most of the evidence supports a reciprocal relationship between stress and symptoms, rather than a causal one. They offered a very plausible explanation as to why patients so often report stress as a precursor to symptom exacerbation: one cannot separate the concurrent stress-symptoms effects, from the delayed stress-stress and symptoms-

symptoms effects, and by integrating them into one experience, it seems as if stress precedes and exacerbates symptoms. Whether or not stress and symptoms have a causal relationship, remains to be elucidated. Perhaps the answer will not be straightforward – we might find that such a relationship exists not for all, but for some of the patients, or not consistently, but some of the time. Such heterogeneity in the magnitude of associations between stress and abdominal pain between participants was present in our data. It was also reported by previous studies (Vork et al., 2020), and evident from stress-symptom correlations having been reported only for subsets of IBS samples (Dancey et al., 1998; Hertig et al., 2007; Levy et al., 1997). In the present study this heterogeneity was illustrated in Figure 1 which presents data from 3 IBS patients with different affect and stress-pain associations over the 14-day period. The observed heterogeneity could be the result of several different factors, for example differences in how people experience stress (physiologically and psychologically) and how they cope with the stress they have experienced. First, patients who are physiologically less responsive to stressful stimuli may not experience a significant effect of those stimuli on their abdominal symptoms. Reported variations in findings on autonomic and HPA axis functioning in IBS patients offer evidence of such interindividual differences (Böhmelt et al., 2005; Kennedy et al., 2014; Mazurak et al., 2012). Secondly, considering that we did not measure physiological stress, but rather perceived stress, we must acknowledge that there are differences in what people report as stressful (Mroczek et al., 2004). Third, interindividual differences in how people deal with the experience of stress are best described using coping strategies. Findings reported by Lackner et al. (2010) indicate that IBS patients who employ more effective coping strategies could in effect be buffering the effects of stress on their symptoms, or specifically, their abdominal pain. And finally, there are different types of stressors which can have different effects on symptom generation and perpetuation (Mayer et al., 2001), which we did not control for in the present study.

The main limitations of this study are its correlational nature, which does not allow for making causal inferences on the nature of the stress-symptom relationship and the relatively small sample size. Also, end-of day retrospective diary assessment might not be the most appropriate method for capturing stress-symptom associations. Considering all of the above, the conclusions of this study are limited. However, prospective studies of this type are rare due to the level of engagement which is required from the patients and the time it takes for data collection, thus the contribution from this clinical sample might be valuable for directing future research.

Clinical implications of this study are in line with previous research, despite the small sample size. Although the results indicate that there are no correlations between day-to-day stress and abdominal pain in IBS patients, and only point to a marginal effect of average stress on average pain scores, this does not mean that stress is irrelevant for IBS. On the contrary, research indicates that the impact of

stress on IBS outcomes (quality of life, burden of illness, symptom severity) is more indirect than direct - through cognitive and behavioural processes which maintain symptoms. For example, it seems that maladaptive coping strategies (rigid coping style accompanied by problem focused strategies) related to cognitive alterations (impaired cognitive flexibility and problem solving) and negative mood (worry, anxiety, catastrophizing) are especially important for IBS. Cognitive-behavioural therapies (CBT) which focus on these mechanisms seem to be most effective and have a long-lasting impact on the improvement of IBS symptoms (Lackner et al., 2022). Meta-analyses show that psychotherapy in general is effective for reducing various psychosocial symptoms in IBS patients, including anxiety, depression, and catastrophizing, but most importantly, psychotherapy leads to a reduction in GI symptoms (Black et al., 2020; Hetterich & Stengel, 2020). CBT interventions (specifically minimum contact CBT, standard CBT and group CBT) have the most consistent effects, and have been shown to be more effective than active control programs (such as psychoeducation) which also have some positive effects on treatment outcomes (Black et al., 2020). In addition to symptom reduction, CBT results in significant improvements in psychosocial functioning of IBS patients, including quality of life, visceral anxiety and negative cognitions (Craske et al., 2011; Ljótsson et al., 2011).

Specific therapeutic techniques which simultaneously lead to improvements in psychosocial outcomes (stress, quality of life) and symptom-related outcomes (pain, bowel dysfunction, symptom severity), some of which are utilized in CBT, include: support or empathy, symptom self-monitoring, self-monitoring of cognitions, finding associations between symptoms and cognitions, providing feedback, problem solving, encouraging rehearsal. It also seems that explaining the working mechanisms of an intervention improves its effectiveness (Henrich et al., 2015, Hetterich & Stengel, 2020). For detailed information on CBT for IBS, see Lackner (2020).

From the CBT perspective, it is the interpretation of events, not the events themselves, which increases the intensity of negative emotions and feelings, negative thoughts, and physical symptoms such as pain. Teaching patients how to employ effective cognitive strategies in order to challenge their beliefs and attitudes about their own health leads to a change in the way patients interpret information. This is important especially for patients experiencing heightened stress, who see themselves as vulnerable and unable to cope with stressful events, which consequently leads to excessive worry about future events (for example, having bowel-related accidents in public). Worrying about events which are unlikely to happen is negatively reinforced by the events not occurring – which further increases worrying in the future. This vicious cycle of stress, negative emotions, symptoms and behaviour can be broken by challenging beliefs about future events, specifically by training patients to monitor and evaluate their own thoughts and feelings (Lackner, 2020). Our results

point to a marginally significant between-subject effect of stress on pain, in other words we found that patients with higher average stress levels seem to experience more pain. Based on the CBT approach, these patients may be interpreting their pain more intensely because of limited psychological resources and stress-related changes in mood (lower positive and higher negative mood). Applying CBT techniques based on the obtained results would indicate, for example, combining symptom self-monitoring (in order to detect what precedes symptoms and if any patterns exist) with relaxation training (with the aim of reducing physiological arousal) and flexible problem solving (teaching patients adaptive coping strategies – problem oriented in the case of controllable problems and emotion-oriented for uncontrollable problems) in order to reduce patients' stress levels, and consequently the level of reported pain. On a day-to-day level, the obtained results underline the significance of low positive mood and high negative mood, which are both related to increased daily stress and increased daily pain levels. It could be proposed that employing emotion (and cognition) self-monitoring, combined with symptom self-monitoring, and making connections between the two, could be effective in pain reduction, and possibly daily stress alleviation in IBS patients (Henrich et al., 2015).

### Authors' Notes

**Funding:** This study was financially supported by University of Rijeka (Grant Number 13.04.1.3.1).

**Competing interests:** The authors declare that there are no potential conflicts of interest associated with this publication, and that any financial support has been noted in the Acknowledgment section.

**Ethics approval:** This study was performed in line with APA ethical standards and the principles of the Declaration of Helsinki. Approval was granted by the Ethics Committees of Clinical Hospital Centre Rijeka (February 6th, 2018.; Class 003-05/18-1/11, Reg. No. 2170-29-02/15-18-2) and Clinical Hospital Sv. Duh Zagreb (January 25th, 2018.; Reg. No. 01-384).

**Consent:** Informed consent was obtained from all participants included in the study.

### References

- Bates, D. M., Mächler, M., Bolker, B., & Walker, S. (2015). Fitting Linear Mixed-Effects Models Using lme4. *Journal of Statistical Software*, 67(1), 1–48. <https://doi.org/10.18637/jss.v067.i01>

- Black, C. J., Thakur, E. R., Houghton, L. A., Quigley, E., Moayyedi, P., & Ford, A. C. (2020). Efficacy of psychological therapies for irritable bowel syndrome: systematic review and network meta-analysis. *Gut*, 69(8), 1441–1451. <https://doi.org/10.1136/gutjnl-2020-321191>
- Blanchard, E. B. (2001). *Irritable bowel syndrome: Psychosocial assessment and treatment*. Washington, D.C.: American Psychological Association.
- Blanchard, E. B., Lackner, J. M., Jaccard, J., Rowell, D., Carosella, A. M., Powell, C., et al. (2008). The role of stress in symptom exacerbation among IBS patients. *Journal of Psychosomatic Research*, 64(2), 119–128. <https://doi.org/10.1016/j.jpsychores.2007.10.010>
- Böhmelt, A. H., Nater, U. M., Franke, S., Hellhammer, D. H., & Ehlert, U. (2005). Basal and stimulated hypothalamic-pituitary-adrenal axis activity in patients with functional gastrointestinal disorders and healthy controls. *Psychosomatic Medicine*, 67(2), 288–294. <https://doi.org/10.1097/01.psy.0000157064.72831.ba>
- Chan, Y., So, S. H., Mak, A. D. P., Siah, K. T. H., Chan, W., & Wu, J. C. Y. (2019). The temporal relationship of daily life stress, emotions, and bowel symptoms in irritable bowel syndrome—Diarrhea subtype: A smartphone-based experience sampling study. *Neurogastroenterology & Motility*, 31(3), e13514. <https://doi.org/10.1111/nmo.13514>
- Chang, L., Sundaresh, S., Elliott, J., Anton, P. A., Baldi, P., Licudine, A., et al. (2009). Dysregulation of the hypothalamic-pituitary-adrenal (HPA) axis in irritable bowel syndrome. *Neurogastroenterology & Motility*, 21(2), 149–159. <https://doi.org/10.1111/j.1365-2982.2008.01171.x>
- Chen, H.-H., Hung, C.-H., Kao, A.-W., & Hsieh, H.-F. (2021). Exploring Quality of Life, Stress, and Risk Factors Associated with Irritable Bowel Syndrome for Female University Students in Taiwan. *International Journal of Environmental Research and Public Health*, 18(8), 3888. <https://doi.org/10.3390/ijerph18083888>
- Cohen, J. (1992). A power primer. *Psychological Bulletin*, 112(1), 155–159. <https://doi.org/10.1037/0033-2909.112.1.155>
- Craske, M. G., Wolitzky-Taylor, K. B., Labus, J., Wu, S., Frese, M., Mayer, E. A., & Naliboff, B. D. (2011). A cognitive-behavioral treatment for irritable bowel syndrome using interoceptive exposure to visceral sensations. *Behaviour research and therapy*, 49(6-7), 413–421. <https://doi.org/10.1016/j.brat.2011.04.001>
- Creed, F. H., Levy, R. L., Bradley, L., Drossman, D. A., Francisconi, C., Naliboff, B. D., & Olden, K. W. (2006). Psychosocial aspects of functional gastrointestinal disorders. In D. A. Drossman, E. Corazziari, M. Delvaux, R. C. Spiller, N. J. Talley, W. G. Thompson, & W. E. Whitehead (Eds.), *Rome III: The functional gastrointestinal disorders* (pp. 295–368). McLean, VA: Degnon Associates Inc.

- Dancey, C. P., Taghavi, M., & Fox, R. J. (1998). The relationship between daily stress and symptoms of irritable bowel: a time-series approach. *Journal of Psychosomatic Research*, 44(5), 537–545. [https://doi.org/10.1016/S0022-3999\(97\)00255-9](https://doi.org/10.1016/S0022-3999(97)00255-9)
- Deary, V., Chalder, T., & Sharpe, M. (2007). The cognitive behavioural model of medically unexplained symptoms: A theoretical and empirical review. *Clinical Psychology Review*, 27(7), 781–797. <https://doi.org/10.1016/j.cpr.2007.07.002>
- Diener, E., & Emmons, R. A. (1984). The independence of positive and negative affect. *Journal of Personality and Social Psychology*, 47(5), 1105–1117. <https://doi.org/10.1037/0022-3514.47.5.1105>
- Drossman, D. A., & Hasler, W. L. (2016). Rome IV—Functional GI Disorders: Disorders of Gut-Brain Interaction. *Gastroenterology*, 150(6), 1257–1261. <https://doi.org/10.1053/j.gastro.2016.03.035>
- Drossman, D. A., McKee, D. C., Sandler, R. S., Mitchell, C. M., Cramer, E. M., Lowman, B. C., & Burger, A. L. (1988). Psychosocial Factors in the Irritable Bowel Syndrome. *Gastroenterology*, 95(3), 701–708. [https://doi.org/10.1016/S0016-5085\(88\)80017-9](https://doi.org/10.1016/S0016-5085(88)80017-9)
- Gros, D. F., Antony, M. M., McCabe, R. E., & Swinson, R. P. (2009). Frequency and severity of the symptoms of irritable bowel syndrome across the anxiety disorders and depression. *Journal of Anxiety Disorders*, 23(2), 290–296. <https://doi.org/10.1016/j.janxdis.2008.08.004>
- Halpert, A., & Drossman, D. (2005). Biopsychosocial Issues in Irritable Bowel Syndrome. *Journal of Clinical Gastroenterology*, 39(8), 665–669. <https://doi.org/10.1097/01.mcg.0000174024.81096.44>
- Hauser, G., Pletikosić, S., & Tkalčić, M. (2014). Cognitive behavioral approach to understanding irritable bowel syndrome. *World Journal of Gastroenterology*, 20(22), 6744. <https://doi.org/10.3748/wjg.v20.i22.6744>
- Heitkemper, M., Burr, R. L., Jarrett, M., Hertig, V., Lustyk, M. K., & Bond, E. F. (1998). Evidence for autonomic nervous system imbalance in women with irritable bowel syndrome. *Digestive Diseases and Sciences*, 43(9), 2093–2098. <https://doi.org/10.1023/A:1018871617483>
- Henningsen, P., Zimmermann, T., & Sattel, H. (2003). Medically Unexplained Physical Symptoms, Anxiety, and Depression. *Psychosomatic Medicine*, 65(4), 528–533. <https://doi.org/10.1097/01.PSY.0000075977.90337.E7>
- Henrich, J. F., Knittle, K., De Gucht, V., Warren, S., Dombrowski, S. U., & Maes, S. (2015). Identifying effective techniques within psychological treatments for irritable bowel syndrome: a meta-analysis. *Journal of psychosomatic research*, 78(3), 205–222. <https://doi.org/10.1016/j.jpsychores.2014.12.009>
- Hertig, V. L., Cain, K. C., Jarrett, M. E., Burr, R. L., & Heitkemper, M. M. (2007). Daily Stress and Gastrointestinal Symptoms in Women With Irritable Bowel

- Syndrome. *Nursing Research*, 56(6), 399–406. <https://doi.org/10.1097/01.NNR.0000299855.60053.88>
- Hetterich, L., & Stengel, A. (2020). Psychotherapeutic Interventions in Irritable Bowel Syndrome. *Frontiers in psychiatry*, 11, 286. <https://doi.org/10.3389/fpsy.2020.00286>
- Hood, S. D., Shufflebotham, J. Q., Hendry, J., Hince, D. A., Rich, A. S., Probert, C. S. J., & Potokar, J. (2008). Irritable Bowel Syndrome Patients Exhibit Depressive and Anxiety Scores in the Subsyndromal Range. *The Open Psychiatry Journal*, 2(1), 12–22. <https://doi.org/10.2174/1874354400802010012>
- Houben, M., Van Den Noortgate, W., & Kuppens, P. (2015). The relation between short-term emotion dynamics and psychological well-being: A meta-analysis. *Psychological Bulletin*, 141(4), 901–930. <https://doi.org/10.1037/a0038822>
- Hox, J. J. (2010). Quantitative methodology series. Multilevel analysis: Techniques and applications (2nd ed.). Routledge/Taylor & Francis Group.
- Kardum, I., & Bezinović, P. (1992). Metodološke i teorijske implikacije pri konstrukciji skale za mjerenje emocionalnog doživljavanja. *Godišnjak zavoda za psihologiju*, 1, 53–60.
- Kennedy, P. J., Clarke, G., Quigley, E. M. M., Groeger, J. A., Dinan, T. G., & Cryan, J. F. (2012). Gut memories: Towards a cognitive neurobiology of irritable bowel syndrome. *Neuroscience and Biobehavioral Reviews*, 36(1), 310–340. <https://doi.org/10.1016/j.neubiorev.2011.07.001>
- Kennedy, P. J., Cryan, J. F., Quigley, E. M. M., Dinan, T. G., & Clarke, G. (2014). A sustained hypothalamic–pituitary–adrenal axis response to acute psychosocial stress in irritable bowel syndrome. *Psychological Medicine*, 44(14), 3123–3134. <https://doi.org/10.1017/S003329171400052X>
- Kovács, Z., & Kovács, F. (2007). Depressive and Anxiety Symptoms, Dysfunctional Attitudes and Social Aspects in Irritable Bowel Syndrome and Inflammatory Bowel Disease. *The International Journal of Psychiatry in Medicine*, 37(3), 245–255. <https://doi.org/10.2190/PM.37.3.a>
- Lackner, J. M. (2020): Skills over pills? A clinical gastroenterologist’s primer in cognitive behavioral therapy for irritable bowel syndrome, *Expert Review of Gastroenterology & Hepatology*, <https://doi.org/10.1080/17474124.2020.1780118>
- Lackner, J. M., Brasel, A. M., Quigley, B. M., Keefer, L., Krasner, S. S., Powell, C., et al. (2010). The ties that bind: perceived social support, stress, and IBS in severely affected patients. *Neurogastroenterology & Motility*, 22(8), 893–900. <https://doi.org/10.1111/j.1365-2982.2010.01516.x>
- Lackner, J. M., Gudleski, G. D., Radziwon, C. D., Krasner, S. S., Firth, R. S., Naliboff, B. D., Vargovich, A. M., Borden, A. B., & Mayer, E. A. (2022). Cognitive flexibility improves in cognitive behavioral therapy for irritable

- bowel syndrome but not nonspecific education/support. *Behaviour research and therapy*, 154, 104033. <https://doi.org/10.1016/j.brat.2022.104033>
- Lacy, B. E., Mearin, F., Chang, L., Chey, W. D., Lembo, A. J., Simren, M., & Spiller, R. (2016). Bowel Disorders. *Gastroenterology*, 150(6), 1393-1407.e5. <https://doi.org/10.1053/j.gastro.2016.02.031>
- Lamers, F., Swendsen, J., Cui, L., Husky, M., Johns, J., Zipunnikov, V., & Merikangas, K. R. (2018). Mood reactivity and affective dynamics in mood and anxiety disorders. *Journal of Abnormal Psychology*, 127(7), 659–669. <https://doi.org/10.1037/abn0000378>
- Larsson, U. F., Brink, E., Grankvist, G., Jonsdottir, I. H., & Alsen, P. (2015). The Single-Item Measure of Stress Symptoms after Myocardial Infarction and Its Association with Fatigue. *Open Journal of Nursing*, 05(04), 345–353. <https://doi.org/10.4236/ojn.2015.54037>
- Lee, C., Doo, E., Choi, J. M., Jang, S., Ryu, H.-S., Lee, J. Y., et al. (2017). The Increased Level of Depression and Anxiety in Irritable Bowel Syndrome Patients Compared with Healthy Controls: Systematic Review and Meta-analysis. *Journal of Neurogastroenterology and Motility*, 23(3), 349–362. <https://doi.org/10.5056/jnm16220>
- Levy, R. L., Cain, K. C., Jarrett, M., & Heitkemper, M. M. (1997). The relationship between daily life stress and gastrointestinal symptoms in women with irritable bowel syndrome. *Journal of behavioral medicine*, 20(2), 177–93. <https://doi.org/10.1023/a:1025582728271>
- Little, T. D., Slegers, D. W., & Card, N. A. (2006). A Non-arbitrary Method of Identifying and Scaling Latent Variables in SEM and MACS Models. *Structural Equation Modeling: A Multidisciplinary Journal*, 13(1), 59–72. [https://doi.org/10.1207/s15328007sem1301\\_3](https://doi.org/10.1207/s15328007sem1301_3)
- Ljótsson, B., Hedman, E., Andersson, E., Hesser, H., Lindfors, P., Hursti, T., Rydh, S., Rück, C., Lindefors, N., & Andersson, G. (2011). Internet-delivered exposure-based treatment vs. stress management for irritable bowel syndrome: a randomized trial. *The American journal of gastroenterology*, 106(8), 1481–1491. <https://doi.org/10.1038/ajg.2011.139>
- Martin, C. R., Osadchiy, V., Kalani, A., & Mayer, E. A. (2018). The Brain-Gut-Microbiome Axis. In CMGH (Vol. 6, Issue 2, pp. 133–148). Elsevier Inc. <https://doi.org/10.1016/j.jcmgh.2018.04.003>
- Mayer, E. A., Naliboff, B. D., Chang, L., & Coutinho, S. V. (2001). V. Stress and irritable bowel syndrome. *American Journal of Physiology-Gastrointestinal and Liver Physiology*, 280(4), G519–G524. <https://doi.org/10.1152/ajpgi.2001.280.4.G519>
- Mayer, E. A., Ryu, H. J., & Bhatt, R. R. (2023). The neurobiology of irritable bowel syndrome. In *Molecular Psychiatry* (Vol. 28, Issue 4, pp. 1451–1465). Springer Nature. <https://doi.org/10.1038/s41380-023-01972-w>

- Mazurak, N., Seredyuk, N., Sauer, H., Teufel, M., & Enck, P. (2012). Heart rate variability in the irritable bowel syndrome: A review of the literature. *Neurogastroenterology and Motility*, 24(3), 206–216. <https://doi.org/10.1111/j.1365-2982.2011.01866.x>
- Midenfjord, I., Polster, A., Sjövall, H., Törnblom, H., & Simrén, M. (2019). Anxiety and depression in irritable bowel syndrome: Exploring the interaction with other symptoms and pathophysiology using multivariate analyses. *Neurogastroenterology and Motility*, 31(8), 1–14. <https://doi.org/10.1111/nmo.13619>
- Mroczek, D. K., & Almeida, D. M. (2004). The Effect of Daily Stress, Personality, and Age on Daily Negative Affect. *Journal of Personality*, 72(2), 355–378. <https://doi.org/10.1111/j.0022-3506.2004.00265.x>
- Mujagic, Z., Leue, C., Vork, L., Lousberg, R., Jonkers, D. M. A. E., Keszthelyi, D., et al. (2015). The Experience Sampling Method - a new digital tool for momentary symptom assessment in IBS: an exploratory study. *Neurogastroenterology & Motility*, 27(9), 1295–1302. <https://doi.org/10.1111/nmo.12624>
- Nakagawa, S., Johnson, P. C. D., & Schielzeth, H. (2017). The coefficient of determination  $R^2$  and intra-class correlation coefficient from generalized linear mixed-effects models revisited and expanded. *Journal of The Royal Society Interface*, 14(134), 20170213. <https://doi.org/10.1098/rsif.2017.0213>
- Ng, C., Malcolm, A., Hansen, R., & Kellow, J. (2007). Feeding and colonic distension provoke altered autonomic responses in irritable bowel syndrome. *Scandinavian Journal of Gastroenterology*, 42(4), 441–446. <https://doi.org/10.1080/00365520600965749>
- Palsson, O. S., Whitehead, W., Törnblom, H., Sperber, A. D., & Simren, M. (2020). Prevalence of Rome IV Functional Bowel Disorders Among Adults in the United States, Canada, and the United Kingdom. *Gastroenterology*, 158(5), 1262–1273.e3. <https://doi.org/10.1053/j.gastro.2019.12.021>
- Parker, C. H., Naliboff, B. D., Shih, W., Presson, A. P., Videlock, E. J., Mayer, E. A., & Chang, L. (2019). Negative Events During Adulthood Are Associated With Symptom Severity and Altered Stress Response in Patients With Irritable Bowel Syndrome. *Clinical Gastroenterology and Hepatology*, 17(11), 2245–2252. <https://doi.org/10.1016/j.cgh.2018.12.029>
- Pletikosić, S., & Tkalčić, M. (2016). The Role of Stress in IBS Symptom Severity. *Psychological Topics*, 25(1), 29–43.
- Revelle, W., & Wilt, J. (2019). Analyzing dynamic data: A tutorial. *Personality and Individual Differences*, 136(August 2017), 38–51. <https://doi.org/10.1016/j.paid.2017.08.020>
- Qin, H.-Y., Cheng, C.-W., Tang, X.-D., & Bian, Z.-X. (2014). Impact of psychological stress on irritable bowel syndrome. *World Journal of Gastroenterology*, 20(39), 14126. <https://doi.org/10.3748/wjg.v20.i39.14126>

- R Core Team. (2020). R: A Language and Environment for Statistical Computing. Vienna, Austria. <https://www.r-project.org/>
- Rahal, H., Videlock, E. J., Icenhour, A., Shih, W., Naliboff, B., Gupta, A., Mayer, E. A., & Chang, L. (2020). Importance of trauma-related fear in patients with irritable bowel syndrome and early adverse life events. *Neurogastroenterology and Motility*, 32(9). <https://doi.org/10.1111/nmo.13896>
- Richardson, C. M. E. (2017). Emotion regulation in the context of daily stress: Impact on daily affect. *Personality and Individual Differences*, 112, 150–156. <https://doi.org/10.1016/j.paid.2017.02.058>
- Schoevers, R. A., van Borkulo, C. D., Lamers, F., Servaas, M. N., Bastiaansen, J. A., Beekman, A. T. F., et al. (2021). Affect fluctuations examined with ecological momentary assessment in patients with current or remitted depression and anxiety disorders. *Psychological Medicine*, 51(11), 1906–1915. <https://doi.org/10.1017/S0033291720000689>
- Suls, J., Wan, C. K., & Blanchard, E. B. (1994). A multilevel data-analytic approach for evaluation of relationships between daily life stressors and symptomatology: Patients with irritable bowel syndrome. *Health Psychology*, 13(2), 103–113. <https://doi.org/10.1037/0278-6133.13.2.103>
- van Orshoven, N. P., Andriessse, G. I., van Schelven, L. J., Smout, A. J., Akkermans, L. M. A., & Oey, P. L. (2006). Subtle involvement of the parasympathetic nervous system in patients with irritable bowel syndrome. *Clinical Autonomic Research*, 16(1), 33–39. <https://doi.org/10.1007/s10286-006-0307-x>
- Van Oudenhove, L., Levy, R. L., Crowell, M. D., Drossman, D. A., Halpert, A. D., Keefer, L., et al. (2016). Biopsychosocial Aspects of Functional Gastrointestinal Disorders: How Central and Environmental Processes Contribute to the Development and Expression of Functional Gastrointestinal Disorders. *Gastroenterology*, 150(6), 1355-1367.e2. <https://doi.org/10.1053/j.gastro.2016.02.027>
- Vork, L., Keszthelyi, D., van Kuijk, S. M. J., Quetglas, E. G., Törnblom, H., Simrén, M., et al. (2020). Patient-Specific Stress–Abdominal Pain Interaction in Irritable Bowel Syndrome: An Exploratory Experience Sampling Method Study. *Clinical and Translational Gastroenterology*, 11(7), e00209. <https://doi.org/10.14309/ctg.0000000000000209>
- Weaver, K. R., Melkus, G. D., Fletcher, J., & Henderson, W. A. (2018). Perceived Stress, Its Physiological Correlates, and Quality of Life in Patients With Irritable Bowel Syndrome. *Biological Research For Nursing*, 20(3), 312–320. <https://doi.org/10.1177/1099800418756733>
- Zamani, M., Alizadeh-Tabari, S., & Zamani, V. (2019). Systematic review with meta-analysis: the prevalence of anxiety and depression in patients with irritable bowel syndrome. In *Alimentary Pharmacology and Therapeutics* (Vol. 50, Issue 2, pp. 132–143). Blackwell Publishing Ltd. <https://doi.org/10.1111/apt.15325>

Zhou, G. Q., Huang, M. J., Yu, X., Zhang, N. N., Tao, S., & Zhang, M. (2023). Early life adverse exposures in irritable bowel syndrome: new insights and opportunities. In *Frontiers in Pediatrics* (Vol. 11). Frontiers Media SA. <https://doi.org/10.3389/fped.2023.1241801>

---

## EVALUATION OF A SCHEMA THERAPY-BASED PREVENTION GROUP PROGRAM FOR CHILDREN AND THEIR PARENTS

---

*Roza Laious<sup>1\*</sup>, Evangelia P. Galanaki<sup>2</sup>, Aikaterini Aggeli<sup>3</sup>,  
Chara Tzavara<sup>4</sup>, Eftychia Argalia<sup>5</sup>, Daria Bakourini<sup>6</sup>, Vassiliki Koutrafour<sup>7</sup>,  
Aikaterini Marini<sup>8</sup>, and Ioanna Sintila<sup>9</sup>*

---

<sup>1</sup> Psychology Laboratory, Department of Pedagogy and Primary Education, School of Education, National and Kapodistrian University of Athens, Greek Society of Schema Therapy, Athens, Greece, and Institute of Behavioral Research and Therapy, Athens, Greece. Email: rozalaious@hotmail.com. ORCID ID: 0009-0006-8397-3239.

<sup>2</sup> Psychology Laboratory, Department of Pedagogy and Primary Education, School of Education, National and Kapodistrian University of Athens. Email: egalanaki@primedu.uoa.gr. ORCID ID: 0000-0002-7519-6146.

<sup>3</sup> Greek Society of Schema Therapy, Athens, Greece and Institute of Behavioral Research and Therapy, Athens, Greece. Email: agelikaterina@gmail.com. ORCID ID: 0000-0002-5889-6933.

<sup>4</sup> School of Medicine, National and Kapodistrian University of Athens, Athens, Greece. Email: htzavara@med.uoa.gr. ORCID ID: 0000-0003-3242-9066.

<sup>5</sup> Greek Society of Schema Therapy, Athens, Greece, and Institute of Behavioral Research and Therapy, Athens, Greece. Email: eargalia@gmail.com. ORCID ID: 0009-0008-3090-3346.

<sup>6</sup> Greek Society of Schema Therapy, Athens, Greece and Institute of Behavioral Research and Therapy, Athens, Greece. Email: dariabak@gmail.com. ORCID ID: 0009-0007-3886-4284.

<sup>7</sup> Greek Society of Schema Therapy, Athens, Greece. E-mail: vkoutrafour@gmail.com. ORCID ID: 0009-0005-2126-4720.

<sup>8</sup> School of Medicine, National and Kapodistrian University of Athens and Greek Society of Schema Therapy, Athens, Greece. Email: kmarini@med.uoa.gr. ORCID ID: 0009-0003-8947-1422.

<sup>9</sup> Greek Society of Schema Therapy, Athens, Greece and Institute of Behavioral Research and Therapy, Athens, Greece. Email: jsintila@hotmail.com. ORCID ID: 0009-0004-1100-8988.

---

### Abstract

Although Schema Therapy has emerged as an effective treatment for a large range of psychopathology, there is limited research on its effectiveness with children and adolescents, especially for preventive purposes, in individual or group settings and with the involvement of parents. Therefore, the aim of this study was to conduct a preliminary evaluation of a newly developed group

---

\* Correspondence concerning this article should be addressed to Roza Laious, Psychology Laboratory, Department of Pedagogy and Primary Education, School of Education, National and Kapodistrian University of Athens, Navarinou 13A, 10680 Athens, Greece, Greek Society of Schema Therapy, Athens, Greece, and Institute of Behavioral Research and Therapy, Athens, Greece. Email: rozalaious@hotmail.com.

prevention program based on Schema Therapy (rationale, principles, and techniques) for children and their parents. It is a psychoeducational, developmentally-appropriate program addressing core emotional needs, early maladaptive schemas, schema modes, coping styles, and parent-child relationship with the aim of preventing the emergence of psychopathology in children. Participants were 90 Greek children (aged 9-13) who attended 16 weekly meetings and their parents who attended 10 biweekly meetings. The effectiveness of the program was evaluated with pre-and-post-intervention assessment (i.e., pre-experimental design). Children's early maladaptive schemas (self-reports) and strengths and difficulties (self- and parent-reports), as well as parents' early maladaptive schemas (self-reports) were assessed. Results showed a significant decrease in most early maladaptive schemas of children and in many early maladaptive schemas of parents. A significant decrease was found in children's emotional symptoms, peer relationship problems and total difficulties score and a significant increase in prosocial behavior. The supporting evidence for the effectiveness of the program and the necessity of evidence-based prevention programs based on Schema Therapy for children and parents are discussed.

**Keywords:** Schema Therapy, prevention, group intervention, core emotional needs, early maladaptive schemas, psychopathology, children, parents.

Schema Therapy is an evidence-based therapeutic approach that was introduced as an effective treatment mostly of personality disorders (Farrell et al., 2014) and chronic, persistent emotional disorders (Bach et al., 2017). It has also been used in group settings (Dickhaut & Arntz, 2014; Farrell et al., 2009, 2014; Skewes et al., 2015), and in couples therapy (Chan & Tan, 2020; Simeone-DiFrancesco et al., 2015). It is an integrative, multi-modal approach that shares essential features with Cognitive Behavioral Therapy, Object Relations Theory, Attachment Theory, Gestalt Therapy, and Transactional Psychoanalysis (Young & Brown, 2003), and has integrated elements from Dialectical Behavioral Therapy, Positive Psychology, and Mentalization-Based Therapy (Lockwood & Shaw, 2012; Montgomery-Graham, 2016; Taylor & Arntz, 2016; Young & Brown, 2003).

Up to date, there are very few Schema Therapy or Schema Therapy-based interventions for children and adolescents (Geerdink et al., 2012). Some of them target only children and adolescents (Alizadeh et al., 2015; Saravi et al., 2020), some others include parents as well (Roelofs et al., 2016; Sabzi et al., 2022; Salehi et al., 2017), whereas others target only parents (Louis & Louis, 2015; Louis et al., 2021). Furthermore, to our knowledge, there is no psychoeducational prevention program based on Schema Therapy that targets both children or adolescents and their parents. Therefore, this study focuses on the evaluation of a newly developed group

prevention program which is based on Schema Therapy and includes both children and their parents.

### *Schema Therapy*

Schema Therapy is based on the premise that all individuals are born with the following *core emotional needs* (Young et al., 2003): (a) secure attachment to others, including safety, stability, nurturance, and acceptance; (b) autonomy, competence, and sense of identity; (c) freedom to express valid needs and emotions; (d) spontaneity and play; and (e) realistic limits and self-control. When these needs are not met or are met excessively, there is an increased risk for the emergence of *early maladaptive schemas*. These schemas develop during childhood and adolescence and are broad and pervasive themes or patterns, comprised of memories, emotions, cognitions, and bodily sensations regarding oneself and one's relationships with others (Farrell et al., 2014; Young et al., 2003). Five *schema domains* have been identified that correspond to the five core emotional needs mentioned above: (a) Disconnection and Rejection, (b) Impaired Autonomy and Performance, (c) Impaired Limits, (d) Other-Directedness, and (e) Overvigilance and Inhibition (Young et al., 2003). For example, some early maladaptive schemas that belong to these schema domains are Mistrust/Abuse, Dependence/Incompetence, Entitlement/Grandiosity, Subjugation, and Negativity/Pessimism, respectively.

Furthermore, early maladaptive schemas are associated with *coping styles* for survival and self-protection, that is, Surrender, Avoidance, and Overcompensation (van Genderen et al., 2012). These coping styles emerge in childhood and are effective ways of dealing with difficulties during that age period, but in the long term they become dysfunctional. Specifically, the Surrender coping style leads individuals to give in to certain early maladaptive schemas and adapt their thoughts and feelings to them. The Avoidance coping style means that individuals avoid situations that trigger certain early maladaptive schemas and the accompanying emotions. The Overcompensation coping style means that individuals behave in a way opposite to certain early maladaptive schemas to prevent their activation.

Although early maladaptive schemas seem rather functional because they ensure survival in less-than-optimal contexts, they put children at risk for psychopathology (Farrell et al., 2014). Early maladaptive schemas that are shaped during childhood constitute the unconditional schemas, whereas those shaped later are regarded as conditional schemas (Roediger et al., 2018; Young et al., 2003). The *unconditional schemas*, such as Emotional Deprivation, Mistrust/Abuse, and Social Isolation/Alienation, are persistent in time and circumstances and are experienced with great intensity (McCarthy & Lumley, 2012; Young et al., 2003). These schemas typically emerge during childhood (McCarthy & Lumley, 2012; Stallard, 2007). The *conditional schemas*, such as Self-Sacrifice, Subjugation, and Emotional Inhibition,

appear later in life as the result of the individual's attempt to avoid the negative consequences of the unconditional schemas and to deal with them (Loose et al., 2013; Young & Brown, 2003).

Moreover, Young and First (2003) introduced the notion of *schema modes* to describe the moment-to-moment fluctuating features of thinking, feeling, and behaving; modes also include activated schemas and coping styles. Schema modes in adults are grouped into the following four categories (Lobbestael et al., 2007; van Genderen et al., 2012): (a) child modes (i.e., Vulnerable Child, Abandoned and Abused Child, Lonely Child, Dependent Child, Angry Child, Enraged Child, Impulsive Child, Undisciplined Child, Happy Child); (b) maladaptive coping modes (i.e., Surrender: Compliant Surrender, Surrender to damaged child modes; Avoidance: Detached Protector, Detached Self-Soother, Avoidant Protector, Angry Protector; Overcompensation: Attention and Approval Seeker, Self-Aggrandizer, Over-controller, Bully and Attack, Conning and Manipulative, Predator); (c) maladaptive parent modes (i.e., Punitive Parent, Demanding Parent); and (d) healthy mode (i.e., Healthy Adult).

Furthermore, in Schema Therapy for children and adolescents, the schema modes are grouped into the following four categories (Loose et al., 2020): (a) child modes (i.e., Vulnerable Child, Angry and Enraged Child, Impulsive Child, Undisciplined Child, Spoiled or Egoistic Child, Happy Child); (b) parental or peer modes (i.e., Punitive Parent/Peer); (c) competent modes (i.e., Competent Child, Internalized Caring Parents, Joined Protectors); and (d) dysfunctional modes (i.e., Surrender: Compliant Surrender, Currying Favour; Avoidance: Detached Protector, Dissociated Protector, Regressive Child, Complaining Protector, Angry Protector, Self-Soother or Stimulator, Hyperactive Protector; Overcompensation: Defiant-Oppositional Child, The Dominator, The Perfect, Excessive Controller, Self-Aggrandizer, Dramatist, Intimidator, Conning Mode, Bully and Attack, Predator).

### *Early Maladaptive Schemas and Children's Psychopathology*

A growing body of research in adults (e.g., Bishop et al., 2021; Janovsky et al., 2020; Peeters et al., 2022; Pilkington et al., 2021) offers substantial evidence that early maladaptive schemas are associated with various types of psychopathology. For children and adolescents, in longitudinal and cross-sectional studies with clinical and community samples, associations were found between early maladaptive schemas and various types of psychopathology in children and adolescents, such as anxiety disorders (Calvete et al., 2013a; Ghamkhar Fard et al., 2014; Hajimirrab et al., 2016; Leung & Poon, 2001; Mousavi et al., 2016; Muris, 2006; Van Vlierberghe et al., 2010), depressive symptoms (Alba et al., 2019; Lumley & Harkness, 2007; Roelofs et al., 2011, 2013), aggressiveness (Calvete, 2008; Calvete & Orue, 2010, 2012; Palmer, 2000), oppositional defiant disorder (Van Vlierberghe et al., 2010), conduct problems (Roelofs et al., 2013; Van Vlierberghe et al., 2010), juvenile

delinquency (Calvete, 2008), internalizing and externalizing problems (Abdolahzadeh Rafi et al., 2017; Tsouvelas et al., 2023; van Wijk-Herbrink et al., 2018; Yiğit et al., 2021), eating disorders and obesity (Muris, 2006; Turner et al., 2005; Van Vlierberghe et al., 2007, 2010), substance abuse (Muris, 2006), and perfectionism (Aghayousefi & Amirpour, 2014). Typically, clinical samples have higher levels of early maladaptive schemas compared to nonclinical samples (Rusinek et al., 2013; Simmons et al., 2006; Van Vlierberghe et al., 2007, 2010).

Furthermore, in a retrospective study (Gong & Chan, 2018), psychological distress in adulthood had significant positive links with childhood early maladaptive schemas, which also had positive links with childhood maltreatment. Finally, a recent meta-analysis (Tariq et al., 2021) indicated that specific early maladaptive schemas, that is, those belonging to the Disconnection and Rejection, Impaired Autonomy and Performance, and Other-directedness domains, were associated with higher levels of depressive symptoms in adolescents and young adults.

It is quite important to note that some of the early maladaptive schemas in childhood are considered as adaptive for this age period (Ghamkhar Fard et al., 2014; Rijkeboer & de Boo, 2010). Such schemas are the Self-Sacrifice schema, because it is regarded as an aspect of prosocial behavior, and the schema of Enmeshment/Undeveloped Self, because it reflects the need for a stronger and warmer relationship with parents, which is a quite normative need in childhood.

In sum, existing research supports the idea that early maladaptive schemas are likely to be at the root of psychopathology. These findings underscore the need to prevent the emergence of early maladaptive schemas in childhood as a way of preventing psychopathology both concurrently and longitudinally.

### *Parents and Early Maladaptive Schemas*

Research evidence indicates that parents' early maladaptive schemas are likely to lead them to dysfunctional parenting practices, such as being aloof, unavailable, or inconsistent, not satisfying their children's core emotional needs, using invalidating or punishing practices, and having excessive demands, among others (Basso et al., 2019; Loose et al., 2020; Louis & Louis, 2015; Maçik et al., 2016; Sójta & Strzelecki, 2023; Young et al., 2003). Moreover, parents' early maladaptive schemas seem to be linked to those of their children (Gibson & Francis, 2019; Sundag et al., 2018; Zeynel & Uzer, 2020; Zonnevrijlle & Hildebrand, 2019) and to the emergence of psychopathology in the latter (Gibson & Francis, 2019). For example, significant positive associations have been found between parents' and adolescents' early maladaptive schemas, especially those schemas belonging to the Impaired Limits and the Disconnection and Rejection domains for parents and early maladaptive schemas belonging to the Disconnection and Rejection and the Impaired Autonomy and Performance domains for adolescents (Zonnevrijlle & Hildebrand, 2019).

In addition, adverse childhood experiences (i.e., emotional, sexual, and physical abuse, physical and emotional neglect) were found in a retrospective study (Alaftar & Uzer, 2022) to significantly mediate the relationship between mothers' and children's early maladaptive schemas, especially those belonging to the domain of Disconnection and Rejection. Similar findings emerged in a cross-sectional study with children and adolescents who had antisocial and depressive symptoms (Van Vlierberghe et al., 2007). Finally, the mother's early maladaptive schemas seem to be negatively associated with mother-child bonding (Zafiropoulou et al., 2014) and even with mother-fetus bonding (Nordahl et al., 2019).

In sum, existing evidence supports the need to target parents' own early maladaptive schemas as well as parenting practices when designing programs aiming at the prevention of early maladaptive schemas and psychopathological symptoms in children.

### *Group Schema Therapy for Children and Adolescents*

As noted above, there are very few studies focusing on group Schema Therapy programs targeting children and/or their parents. More specifically, in a study conducted in Iran (Salehi et al., 2017), group Schema Therapy was implemented in children with insecure attachment and separation anxiety as well as in their parents. The results indicated a significant decrease in children's internalizing and externalizing problems. In another study in Iran (Alizadeh et al., 2015), a group Schema Therapy program was implemented in children with cancer and a significant decrease in their depressive symptoms was found. A third study in Iran (Sabzi et al., 2022) reported findings from the implementation of a group Schema Therapy-based program with mothers (only) who had 8-10-year-old daughters. There was a significant decrease in some early maladaptive schemas in children and in dependency in parent-child relationships, as well as an increase in closeness and positive relationship between parents and children, such as affection and attunement to children's emotions.

Regarding adolescents, a Schema Therapy-based group program in four adolescents with personality disorders or features of personality disorders was implemented in the Netherlands (Roelofs et al., 2016). Adolescents were also in individual therapy. The intervention included biweekly sessions with parents. The results indicated a significant decrease in adolescents' early maladaptive schemas, schema modes, and symptoms of psychopathology, as well as an improvement in their quality of life. The most significant change occurred for adolescents whose parents participated in the therapeutic program. In addition, a Schema Therapy-based group program was designed and implemented in overweight adolescents with binge eating disorder in Iran (Saravi et al., 2020). The program consisted of 13 sessions, with a three-month follow-up. The results showed a decrease in adolescents' eating attitude and an increase in their ability for self-regulation.

Finally, the Good Enough Parenting program (Louis & Louis, 2015; Louis et al., 2021), which is based on Schema Therapy, is a program that includes only parents and addresses their early maladaptive schemas, schema modes, and frustrations with their children, with the aim of improving the parent-child relationship by meeting parents' core emotional needs and increasing the quantity and quality of positive interactions. Louis and Louis (2015) reported that this program has been implemented in many countries worldwide, with very encouraging findings. A relevant qualitative research (Louis et al., 2021) indicated that this program enhanced parents' patience and intentionality and enabled them to provide more emotional support to their children and to set limits in a stable and sensitive way.

### *Aims and Hypotheses of the Current Study*

The aim of this study was to conduct a preliminary evaluation of a newly developed psychoeducational prevention program based on Schema Therapy (with regard to rationale, principles, and techniques), that includes both children and their parents (see also Laious et al., 2020, 2022). As a Schema Therapy-based program, it aims at decreasing children's early maladaptive schemas. This is achieved by facilitating children to become aware of their early maladaptive schemas, schema modes, coping styles, and the accompanying emotions, by encouraging children to realize and express their core emotional needs in order to satisfy them, and by educating children in ways to strengthen the Competent modes, that is, the strong, supportive, clever, and wise modes (Loose, 2011, 2020). The program also aims at facilitating parents to become aware of their own and their children's core emotional needs and early maladaptive schemas and to work on improving their relationship with their children (i.e., secure attachment, warmth, emotional reciprocity, emotional attunement). Parents' involvement in the program is necessary because, as outlined above, existing research data have indicated the interconnection of parents' and children's early maladaptive schemas (Gibson & Francis, 2019; Sundag et al., 2018; Zeynel & Uzer, 2020; Zonnevjlle & Hildebrand, 2019) and the significant impact of parents' schemas on their parenting practices and the overall relationship with their children (Basso et al., 2019; Maçik et al., 2016; Nordahl et al., 2019; Sójta & Strzelecki, 2023; Zafiropoulou et al., 2014). As a result, this program is expected to prevent the emergence of children's psychopathological symptoms (Loose et al., 2013). The fact that early maladaptive schemas appear during childhood and adolescence underlines the importance of prevention and early intervention (Muris, 2006; Young et al., 2003).

More specifically, we hypothesize that after the implementation of the program there will be a significant decrease in children's and parents' early maladaptive schemas. Accordingly, there will be a significant decrease in children's

psychopathological symptoms and a significant increase in children's strengths, as assessed by both children and their parents.

## **Method**

### *Research Design*

This study adopted a pre-experimental research design, with a one-group pre-test and post-test scheme (Shaughnessy et al., 2015). Participants completed the measures both at pre-test, that is, two weeks before the intervention and at post-test, that is, one week after the intervention. The intervention, which consisted of 16 weekly sessions for the children's groups and 10 biweekly sessions for the parents' groups, with 90 minutes duration each, lasted four months. It was delivered by the first author, who also acted as a supervisor, and five female psychologists/psychotherapists (co-authors 5-9), all trained in Schema Therapy in the Greek Society of Schema Therapy, which is accredited by the International Society of Schema Therapy. It is also important to note that children's psychopathological symptoms – the main outcome variable – were assessed by both children and their parents.

### *Participants*

Participants were 90 children ( $M_{age} = 11.2$  years,  $SD = 1.0$ ; 52.2% boys) and their 85 parents ( $M_{age} = 44.6$  years,  $SD = 4.0$ ; 87.1% mothers). Of them, 87 children were from Athens and three children from two large cities of northern and southern Greece. Parents' educational level was medium to high: only primary education 1.2%, only secondary education 22.6%, post-secondary education 21.4%, and tertiary education (bachelor's degree or higher) 54.7%.

The initial sample included a control group which was assessed at pre-test. However, it exhibited a high attrition rate which was mainly due to the disruption caused by the COVID-19 pandemic and the strict lockdown measures in Greece; therefore, it was excluded from the final study.

One of the prerequisites for a child to participate in the program was the participation of at least one of his/her parents, however there were two children whose both parents participated. In addition, there were seven children whose siblings participated as well in the program, though in different children's groups.

It is an ad-hoc sample consisting of individuals who volunteered to participate in the study. They were recruited from six randomly selected primary and secondary schools located in Athens, as well as after an open call via social media and via a one-day conference on parenting and children's mental health, organized by the Psychology Laboratory and held at the University of Athens.

The drop-out rate of the participants was small: 10.9%. Eleven children (6 boys) from the initial sample ( $N = 101$ ) dropped out during the period from the first to the seventh session of the program, mainly because of objective obstacles (e.g., changes in daily family schedule, family relocation due to parents' work duties).

### *Measures*

#### *A. Children*

Children reported their age and gender and completed the Schema Inventory for Children and the Strengths and Difficulties Questionnaire.

**Schema Inventory for Children** (SIC; Rijkeboer & de Boo, 2010). It is a self-report inventory consisting of 40 items which assess early maladaptive schemas of children aged 8-13 (Young, 2003). The schemas are arranged in the following 11 subscales: Mistrust/Abuse, Defectiveness/Shame, Enmeshment/Undeveloped Self, Failure, Self-Sacrifice, Unrelenting Standards/Hypercriticalness, Entitlement/Grandiosity, Insufficient Self-Control/Self-Discipline, Loneliness, Vulnerability to Harm or Illness, and Subjugation. Items are scored on a four-point Likert scale (0 = completely untrue of me, 3 = describes me perfectly). The Greek version of the inventory was used (Aggeli et al., in preparation). The internal consistency reliability (Cronbach's alpha) of the subscales of the Greek version is adequate: .70-.78.

**Strengths and Difficulties Questionnaire** (SDQ; Goodman, 1997). This self-report questionnaire consists of 25 items screening for strengths and psychopathological symptoms of children aged 11-16. It includes five subscales: Emotional Symptoms, Conduct Problems, Hyperactivity/Inattention, Peer Relationship Problems, and Prosocial Behavior. Items are scored on a three-point Likert scale (1 = not true, 3 = certainly true). The Greek version of the questionnaire was used (Bibou-Nakou et al., 2001). The internal consistency reliability (Cronbach's alpha) of the Greek version was adequate: .75 for the total questionnaire and .70-.76 for the subscales.

#### *B. Parents*

Parents reported their age, gender, family status, and educational level. They also completed the Strengths and Difficulties Questionnaire-Parent Version and the Young Schema Questionnaire-Short Form3.

**Strengths and Difficulties Questionnaire-Parent Version** (SDQ; Goodman, 1997). It is the parent-version of the SDQ described previously. The Greek version of the questionnaire was used (Bibou-Nakou et al., 2001). The internal consistency reliability (Cronbach's alpha) of the Greek version was adequate: .71 for the total questionnaire and .70-.76 for the subscales.

**Young Schema Questionnaire-Short Form3** (Young, 2003). It is a self-report questionnaire which evaluates early maladaptive schemas. It consists of 90 items arranged in five domains, each one including specific schemas, as follows:

Disconnection and Rejection (Abandonment/Instability, Mistrust/Abuse, Emotional Deprivation, Defectiveness/Shame, Social Isolation/Alienation), Impaired Autonomy and Performance (Dependence/Incompetence, Vulnerability to Harm or Illness, Enmeshment/Undeveloped Self, Failure), Impaired Limits (Entitlement/ Grandiosity, Insufficient Self-Control/Self-Discipline), Other-Directedness (Subjugation, Self-Sacrifice, Approval-Seeking/Recognition-Seeking), and Overvigilance and Inhibition (Negativity/Pessimism, Emotional Inhibition, Unrelenting Standards/ Hypercriticalness, Punitiveness). Items are scored on a six-point Likert scale (1 = completely untrue of me, 6 = describes me perfectly). The Greek version of the questionnaire was used (Malogiannis et al., 2018). The internal consistency reliability (Cronbach's alpha) of the Greek version is adequate: .92 for the total questionnaire and .70-.85 for the subscales.

### *Procedure*

The first author and the five psychologists (co-authors 5-9) contacted the selected primary and secondary schools to check their availability and willingness to participate. After being informed about the study, the volunteering teachers conducted parent meetings in which they presented the aim and the process of the study and asked for participation. Then, the parents who accepted the invitation provided informed written consent.

The first author and the five psychologists conducted an initial interview with each parent-child dyad. The aim of this interview was to screen for diagnosed developmental and/or mental health problems (e.g., autism, mental disorder) in children and their parents. As there was no such diagnosis, no one was excluded. With this process, 10 children's groups and 10 parents' groups were formed, each with 6 to 10 members.

The pre-test was conducted in-person before the onset of the COVID-19 pandemic. The intervention was also conducted in-person up to, on average, the fourth session with children and parents. Before the onset of the pandemic, the group sessions with primary school students were held in schools (in classrooms or in other suitable rooms) and with high school students were held in the psychologists' private offices, due to the secondary schools' restrictions in the use of classrooms. After the onset of the COVID-19 pandemic (March 2020), which necessitated social distancing and lockdown, the sessions were transferred on-line, after the appropriate modifications in the form and content of the program were made.

The study was conducted with permission by the Institute of Educational Policy of the Greek Ministry of Education and with approval by the Research Ethics Committee of the Department of Pedagogy and Primary Education of the National and Kapodistrian University of Athens, Greece (number of approval: 431/10.10.2019). The study has also complied with the ethical standards of the American Psychological Association regarding treatment of the sample, anonymity and confidentiality of data, respect of the participants' rights to withdraw from the study at any time, respect of the participants' right to be informed about the findings, etc.

*Content of the Program*

The program has two separate but interrelated components: group work with children and group work with their parents. Sixteen weekly sessions with children’s groups and 10 biweekly sessions with parents’ groups were held (in-person and on-line sessions). The program adopted the Schema Therapy rationale and included Schema Therapy activities and techniques, which were tailored to the children’s developmental level. Examples of techniques used are the following: “chair work” for the exploration and change of schema modes; imagery to elicit specific emotions; empathic confrontation of early maladaptive schemas, schema modes and coping styles; and limited-reparenting to facilitate validation and correspondence to children’s core emotional needs.

Techniques based on narrative, drawing, and play therapy are also used. More specifically, a new therapeutic story was constructed to facilitate children identify with the main character of the story and, thus, understand the basic concepts of Schema Therapy, that is, core emotional needs and their fulfillment, schema modes, and coping styles. Drawing was used very frequently, as children were asked to illustrate their various schema modes. Play therapy techniques were also implemented in children’s and parents’ groups. These techniques were based on drawings of the schema modes and on role-playing of schema modes and coping styles.

The structure of the program and the aim and abbreviated content of each session with children’s and parents’ groups are summarized in Tables 1 and 2, respectively.

**Table 1.** Structure and Abbreviated Content (Aims and Techniques) of the Sessions for Children’s Groups

No.	Session Theme	Session Aims and Techniques
1	<b>Acquaintance: “Who am I?”</b>	Getting to know each other and the therapist, discussing about the aim of the group, activating members
2	<b>Acquaintance – Goals – Expectations: “What is this group?”</b>	Sharing the expectations and setting limits concerning the function of the group, group bonding
3	<b>Trust in the group: “Can I trust others in the group?”</b>	Developing safety and trust, group bonding
4	<b>Exploring emotions: “How do I feel?”</b>	Exploring emotions, identifying their verbal and nonverbal expression, identifying emotions that disturb the group, developing trust and support, increasing emotional connection, playing, group bonding
5	<b>Children’s core emotional needs I: “What do I need to feel good?”</b>	Learning about core emotional needs and ways to fulfill them, developing trust and support, increasing emotional connection, playing, group bonding

No.	Session Theme	Session Aims and Techniques
6	<b>Children’s core emotional needs II: “What do I need to feel good?”</b>	Identifying core emotional needs, suggesting ways and individuals to fulfill them, developing creativity, increasing emotional connection and cooperation, playing, group bonding
7	<b>Working with schema modes: “Which are the parts of myself?”</b>	Learning about schema modes, sharing personal experiences, developing trust and support, increasing emotional connection, playing, group bonding
8	<b>Working with the Happy Child mode: “When I feel happy!”</b>	Learning about the Happy Child mode, identifying the needs connected with it and suggesting ways and individuals to empower it, sharing personal experiences, developing trust and support, increasing emotional connection, playing, group bonding
9	<b>Working with the Vulnerable Child mode: “When I feel sad, scared, or lonely”</b>	Learning about the Vulnerable Child mode, identifying the needs connected with it and suggesting ways and individuals to sooth it, empowering the Competent modes, sharing personal experiences, developing trust and support, showing empathy, experiencing emotional relief, increasing emotional connection, playing, group bonding
10	<b>Working with the Angry Child mode: “When I feel very angry!”</b>	Learning about the Angry Child mode, identifying the needs connected with it and suggesting ways and individuals to confront it, psychoeducation on appropriate and functional ways to express anger, empowering the Competent modes, sharing personal experiences, developing trust and support, increasing emotional connection, playing, group bonding
11	<b>Working with the Undisciplined/Impulsive Child mode: “Why do I have to do this? I don’t want to!”</b>	Learning about the Undisciplined/Impulsive Child mode, identifying the needs connected with it and suggesting ways and individuals to confront it, psychoeducation on appropriate and functional ways of expression and on setting limits, empowering the Competent modes, sharing personal experiences, developing trust and support, increasing emotional connection, playing, group bonding
12	<b>Working with the Critical/Demanding Voice: “Those bad thoughts that hover over me!”</b>	Learning about the Critical/Demanding Voice, psychoeducation on coping with this Voice, empowering the Competent modes, sharing personal experiences, developing trust and support, increasing emotional connection, playing, group bonding
13	<b>Integration and regulation of schema modes: “How can I handle my difficult parts?”</b>	Working on the schema modes to increase deep understanding of them, empowering the Competent modes, engaging in creative activities (e.g., story, song), developing trust and support, increasing cooperation and emotional connection, playing, group bonding
14	<b>Identifying coping styles: “How do I respond to difficult situations?”</b>	Identifying coping styles, empowering the Competent modes, sharing personal experiences, developing trust, support, and safety, increasing emotional connection, playing, group bonding
15	<b>Self-reflection on coping styles and their use: “How can I handle and improve my coping styles?”</b>	Working on coping styles to increase deep understanding of them, strengthening functional coping styles, empowering the Competent modes, engaging in creative activities (e.g., story, song), sharing personal experiences, developing trust, increasing cooperation and emotional connection, playing, group bonding
16	<b>Closure – Feedback: “My memories from our group”</b>	Sharing feedback from the participation in the group, connecting with the Happy Child mode, expressing feelings and emotions, connecting with the transitional object

**Table 2.** Structure and Abbreviated Content (Aims and Techniques) of the Sessions for Parents' Groups

No.	Session Theme	Session Aims and Techniques
1	<b>Acquaintance – Goals – Expectations</b>	Getting to know each other and the therapist, discussing the aims of the group and its rules, acknowledging the strengths and difficulties of the parental role, group bonding
2	<b>Identifying emotions: “How do I feel?”</b>	Identifying emotions, identifying difficult emotions triggered by their children, sharing personal experiences, developing trust and support, increasing emotional connection, playing, group bonding
3	<b>Identifying children’s and parents’ psychological needs: “What does my child need and what do I need?”</b>	Learning about Schema Therapy and its basic concepts (e.g., core emotional needs, early maladaptive schemas, and schema modes), identifying their children’s and their own core emotional needs, sharing personal experiences, developing trust and support, increasing emotional connection, group bonding
4	<b>Identifying the core emotional needs for secure attachment, connection, and acceptance: “How close do you feel to me?”</b>	Learning about the core emotional needs for secure attachment, connection, and acceptance, sharing personal experiences, learning functional ways of fulfilling these needs, developing trust and support, increasing emotional connection, playing, group bonding
5	<b>Working on the core emotional needs for secure attachment, connection, and acceptance: “How can we feel close to one another?”</b>	Working on the core emotional needs for secure attachment, connection and acceptance, connecting with parents’ Inner Child and with the Vulnerable Child mode, sharing personal experiences, developing trust and support, increasing emotional connection, group bonding
6	<b>Identifying and working on the core emotional needs for autonomy, competence, and sense of identity: “How do I show you that I trust you?”</b>	Identifying and working on the core emotional needs for autonomy, competence, and sense of identity, learning functional ways of fulfilling these needs, sharing personal experiences, developing trust and support, increasing emotional connection, playing, group bonding
7	<b>Identifying and working on the core emotional need for freedom to express valid needs and emotions: “Do I let you express yourself?”</b>	Identifying and working on the core emotional need for freedom to express valid needs and emotions, learning about the Internalized Critical/Demanding Parent Mode, learning functional ways of fulfilling this need, sharing personal experiences, developing trust and support, increasing emotional connection, playing, group bonding
8	<b>Identifying and working on the core emotional need for realistic limits and self-control: “How and why I set limits?”</b>	Identifying and working on the core emotional need for realistic limits and self-control, learning functional ways of fulfilling this need, sharing personal experiences, developing trust and support, increasing emotional connection, playing, group bonding
9	<b>Identifying and working on the core emotional need for spontaneity and play: “I have so much fun playing with you!”</b>	Identifying and working on the core emotional need for spontaneity and play, learning functional ways of fulfilling this need, sharing personal experiences, developing trust and support, increasing emotional connection, playing, group bonding
10	<b>Closure – Feedback: “My memories from our group”</b>	Sharing feedback from the participation in the group, connecting with the Happy Child mode, expressing feelings and emotions, connecting with the transitional object

*Treatment Fidelity*

Although treatment fidelity or integrity was not measured, certain procedures were implemented for the following treatment fidelity dimensions: content or adherence, quantity (i.e., dosage and exposure), and quality or process (Sanetti et al., 2021). More specifically, the program was designed and implemented by trained psychologists/psychotherapists: the first and the third authors, who also acted as clinical supervisors, are clinical psychologists/psychotherapists (PhD), certified in Cognitive Behavioral Therapy in children, adolescents, and adults by the Institute of Behavioural Research and Therapy (accredited by the European Association for Behavioural and Cognitive Therapies), and in Schema Therapy by the Greek Society of Schema Therapy (accredited by the International Society of Schema Therapy), and are also supervisors and trainers of psychotherapists; the second author, who acted as an academic supervisor, is certified in Cognitive Behavioral Therapy by the same Institute and has also received training in psychoanalytic psychotherapy; and the five psychologists (co-authors 5-9) are certified in Schema Therapy and have received additional training in child and adolescent psychotherapy.

Before the implementation of the program, the five psychologists/psychotherapists received systematic and rigorous training by the first and third authors in it. They studied the manual of the program which includes a detailed description of the aims, structure, content, activities, and techniques of the sessions with children and parents, as well as specific guidelines and several ideas for the promotion of communication and interaction within the groups. During the implementation of the program, eight supervision sessions (twice a month) were conducted by the first author. Discussions focused on the psychologists' emotions and therapeutic stance and skills. Special attention was paid to the interactions between the psychologists and the group members (children, parents) as well as among group members. Any issues arising in the groups were discussed. Through role plays, the psychologists practiced their skills in applying the techniques and implementing the activities of the program. Finally, children's and parents' participation (i.e., frequency and duration) was carefully monitored and it was ensured that all of them exhibited commitment and consistency.

*Data Analysis*

Descriptives ( $M$ ,  $SD$ ) for all variables were calculated. The normality assumption of all variables was violated as indicated by the statistically significant Kolmogorov-Smirnov tests, the inspection of histograms, boxplots, and outliers, as well as the skewness and kurtosis values (Field, 2018). Therefore, Wilcoxon signed-

rank tests were used (instead of paired *t*-tests) to examine differences between pre-test and post-test. Effect sizes were calculated with the formula  $r = z / \sqrt{N}$ , where *N* is the number of pairs for the paired samples, that is, 2 x *N* (Rosenthal, 1994). The effect sizes were evaluated based on Cohen’s (1992) suggestions, as follows: 0.10 = small, 0.30 = moderate, and 0.50 = large effect. All analyses were conducted with SPSS version 28.01.0.

**Results**

Kolmogorov-Smirnov tests were statistically significant for nearly all variables studied, therefore a non-parametric test, that is, Wilcoxon signed-rank test, was used to test for differences between pre-test and post-test.

*Children’s Early Maladaptive Schemas*

Table 3 presents the descriptive statistics, the *z*-values of the Wilcoxon signed-rank tests, and the effect sizes for children’s early maladaptive schemas. Statistically significant decreases emerged at post-test for many early maladaptive schemas as experienced by children themselves, that is, for Loneliness, Vulnerability to Harm or Illness, Mistrust/Abuse, Defectiveness/Shame, Failure, Subjugation, Unrelenting Standards/Hypercriticalness, Self-Sacrifice, Entitlement/Grandiosity, and Insufficient Self-Control/Self-Discipline. In contrast, there was a statistically significant increase at post-test in Enmeshment/Undeveloped Self. The effect sizes were relatively small. The largest effect sizes (> 0.20) were observed for Subjugation, Vulnerability to Harm or Illness, Insufficient Self-Control/Self-Discipline, Loneliness, Failure, Mistrust/Abuse, and Entitlement/Grandiosity.

**Table 3.** Means, Standard Deviations, and Wilcoxon Signed-Rank Tests for Children’s Early Maladaptive Schemas (*N* = 90)

Schema Inventory for Children	Pre-test		Post-test		Change		<i>z</i> -value <sup>1</sup>	Effect size <sup>2</sup>
	<i>M</i>	<i>SD</i>	<i>M</i>	<i>SD</i>	<i>M</i>	<i>SD</i>		
Mistrust/Abuse	0.76	0.72	0.54	0.52	0.22	0.69	-2.63**	-0.21
Defectiveness/Shame	0.36	0.51	0.20	0.41	0.16	0.57	-2.40**	-0.19
Enmeshment/Undeveloped Self	1.82	0.65	1.99	0.65	-0.17	0.63	2.37**	-0.19
Failure	0.47	0.71	0.29	0.50	0.16	0.62	-2.76**	-0.22
Self-Sacrifice	1.68	0.78	1.56	0.67	0.12	0.70	-1.58*	-0.13
Unrelenting Standards/Hypercriticalness	1.52	0.74	1.31	0.67	0.21	0.80	-2.28*	-0.18
Entitlement/Grandiosity	0.45	0.57	0.32	0.47	0.13	0.43	-2.61**	-0.21
Insufficient Self-Control/Self-Discipline	1.11	0.72	0.90	0.60	0.21	0.61	-2.96**	-0.24

Schema Inventory for Children	Pre-test		Post-test		Change		z-value <sup>1</sup>	Effect size <sup>2</sup>
	M	SD	M	SD	M	SD		
Loneliness	0.60	0.63	0.40	0.41	0.20	0.62	-2.85**	-0.23
Vulnerability to Harm or Illness	0.62	0.56	0.46	0.54	0.16	0.44	-3.00**	-0.24
Subjugation	0.61	0.57	0.44	0.45	0.17	0.43	-3.25**	-0.27

Note. Scale 0-3. <sup>1</sup> z-value of the Wilcoxon signed-rank test for the pre-test – post-test comparisons.

<sup>2</sup> Effect size:  $r = z / \sqrt{N}$ , N the number of pairs for the paired samples (2 x N).

\* $p < .05$ ; \*\* $p < .01$ .

### Children’s Strengths and Difficulties – Self-Reports

Table 4 presents the descriptive statistics, the z-values of the Wilcoxon signed-rank tests, and the effect sizes for children’s self-reports on their strengths and difficulties. There were statistically significant decreases at post-test in Emotional Symptoms, Peer Relationship Problems, and in the Total Score. The effect sizes were relatively small (> 0.20 for these three variables).

**Table 4.** Means, Standard Deviations, and Wilcoxon Signed-Rank Tests for Children’s Strengths and Difficulties – Self-Reports (N = 90)

Strengths and Difficulties Questionnaire – Self-Reports	Pre-test		Post-test		Change		z-value <sup>1</sup>	Effect size <sup>2</sup>
	M	SD	M	SD	M	SD		
Emotional Symptoms	0.62	0.44	0.50	0.40	0.12	0.41	-2.63**	-0.21
Conduct Problems	0.54	0.28	0.54	0.29	0.00	0.29	-0.07	-0.01
Hyperactivity/Inattention	0.84	0.39	0.82	0.36	0.02	0.38	-0.81	-0.06
Peer Relationship Problems	0.50	0.45	0.40	0.37	0.10	0.31	-2.76**	-0.22
Prosocial Behavior	1.69	0.33	1.71	0.34	-0.02	0.29	0.62	-0.05
Total Score	0.50	0.22	0.45	0.19	0.05	0.17	-2.81**	-0.22

Note. Scale 0-2. <sup>1</sup> z-value of the Wilcoxon signed-rank test for the pre-test – post-test comparisons.

<sup>2</sup> Effect size:  $r = z / \sqrt{N}$ , N the number of pairs of the paired samples (2 x N).

\* $p < .05$ ; \*\* $p < .01$ ; \*\*\* $p < .001$ .

### Children’s Strengths and Difficulties – Parent-Reports

Table 5 presents the descriptive statistics, the z-values of the Wilcoxon signed-rank tests, and the effect sizes for children’s strengths and difficulties as reported by their parents. There were statistically significant decreases at post-test in Emotional Symptoms and in the Total Score. A statistically significant increase emerged at post-test for Prosocial Behavior. The effect sizes were relatively small. The largest effect sizes (> 0.20) were observed for the Total score and the Emotional Symptoms.

**Table 5.** Means, Standard Deviations, and Wilcoxon Signed-Rank Tests for Children's Strengths and Difficulties – Parent-Reports ( $N = 85$ )

Strengths and Difficulties Questionnaire – Parent-Reports	Pre-test		Post-test		Change		z-value <sup>1</sup>	Effect size <sup>2</sup>
	M	SD	M	SD	M	SD		
Emotional Symptoms	0.59	0.47	0.48	0.42	0.11	0.36	-2.67**	-0.21
Conduct Problems	0.50	0.28	0.47	0.28	0.03	0.31	-0.95	-0.08
Hyperactivity/Inattention	0.75	0.40	0.71	0.42	0.04	0.31	-1.24	-0.10
Peer Relationship Problems	0.49	0.38	0.45	0.37	0.04	0.24	-1.36	-0.11
Prosocial Behavior	1.62	0.37	1.71	0.36	-0.09	0.34	2.38*	-0.19
Total Score	0.46	0.18	0.42	0.20	0.04	0.15	-2.82**	-0.22

Note. Scale 0-2. <sup>1</sup> z-value of the Wilcoxon signed-rank test for the pre-test – post-test comparisons.

<sup>2</sup> Effect size:  $r = z / \sqrt{N}$ ,  $N$  the number of pairs for the paired samples ( $2 \times N$ ).

\* $p < .05$ ; \*\* $p < .01$ ; \*\*\* $p < .001$ .

### Parents' Early Maladaptive Schemas

Table 6 presents the descriptive statistics, the z-values of the Wilcoxon signed-rank tests, and the effect sizes for parents' early maladaptive schemas, as experienced by themselves. Statistically significant decreases emerged at post-test in Emotional Deprivation, Mistrust/Abuse, Dependence/Incompetence, Enmeshment/Undeveloped Self, Subjugation, Insufficient Self-Control/Self-Discipline, Approval-Seeking/Recognition-Seeking, Punitiveness and in the Total Score. The effect sizes are relatively small. The largest effect sizes ( $> 0.20$ ) were observed for the Total Score, Mistrust/Abuse, and Dependence/Incompetence.

**Table 6.** Means, Standard Deviations, and Wilcoxon Signed-Rank Tests for Parents' Early Maladaptive Schemas ( $N = 85$ )

Young Schema Questionnaire	Pre-test		Post-test		Change		z-value <sup>1</sup>	Effect size <sup>2</sup>
	M	SD	M	SD	M	SD		
Abandonment/Instability	1.99	0.63	1.93	0.70	0.06	0.51	-1.38	-0.11
Mistrust/Abuse	1.94	0.64	1.79	0.65	0.15	0.53	-2.78**	-0.22
Emotional Deprivation	2.05	0.93	1.91	0.99	0.14	0.63	-1.98*	-0.16
Defectiveness/Shame	1.41	0.58	1.30	0.50	0.11	0.51	-1.85	-0.15
Social Isolation/Alienation	1.82	0.84	1.73	0.86	0.09	0.50	-1.71	-0.14
Dependence/Incompetence	1.61	0.55	1.47	0.52	0.14	0.45	-2.64**	-0.21
Vulnerability to Harm or Illness	1.80	0.72	1.78	0.68	0.02	0.53	-0.02	0.00
Enmeshment/Undeveloped Self	1.75	0.73	1.59	0.70	0.16	0.53	-2.38*	-0.19
Failure	1.56	0.56	1.49	0.57	0.07	0.44	-1.35	-0.11
Entitlement/Grandiosity	2.26	0.78	2.24	0.75	0.02	0.71	-0.44	-0.04
Insufficient Self- Control/Self-Discipline	2.28	0.68	2.12	0.65	0.16	0.58	-2.18**	-0.17
Subjugation	1.93	0.76	1.83	0.81	0.10	0.49	-2.21*	-0.18

Young Schema Questionnaire	Pre-test		Post-test		Change		z-value <sup>1</sup>	Effect size <sup>2</sup>
	M	SD	M	SD	M	SD		
Self-Sacrifice	3.32	0.95	3.22	1.02	0.10	0.93	-1.63	-0.13
Approval-Seeking/ Recognition-Seeking	2.33	0.83	2.18	0.83	0.15	0.61	-2.34*	-0.19
Negativity/Pessimism	2.20	0.78	2.06	0.73	0.14	0.64	-1.69	-0.13
Emotional Inhibition	1.96	0.74	1.93	0.82	0.03	0.64	-0.43	-0.03
Unrelenting Standards/ Hypercriticalness	2.94	0.81	2.83	0.85	0.11	0.79	-1.36	-0.11
Punitiveness	2.14	0.72	1.96	0.69	0.18	0.64	-2.32*	-0.18
Total Score	2.07	0.42	1.97	0.44	0.10	0.29	-3.12**	-0.25

Note. Scale 1-6. <sup>1</sup> z-value of the Wilcoxon signed-rank test for the pre-test – post-test comparisons.

<sup>2</sup> Effect size:  $r = z / \sqrt{N}$ ,  $N$  the number of pairs for the paired samples ( $2 \times N$ ).

\* $p < .05$ ; \*\* $p < .01$ ; \*\*\* $p < .001$ .

## Discussion

The aim of the current study was to conduct a preliminary evaluation of a newly developed Schema Therapy-based psychoeducational prevention program that can be implemented in group settings with children and their parents. The results supported our hypotheses, thus providing support for the effectiveness of the program in decreasing children’s early maladaptive schemas and psychopathological symptoms and in increasing their strengths. Parents’ early maladaptive schemas also decreased.

### *Children’s Early Maladaptive Schemas*

Initially, it is important to note that the most frequently reported early maladaptive schemas among children were Enmeshment/Undeveloped Self, Self-Sacrifice, Unrelenting Standards/Hypercriticalness, and Insufficient Self-Control/Self-Discipline. The levels of these schemas were moderate, whereas on all other schemas children had low scores. These findings are similar to those from existing studies with nonclinical samples of adolescents (Muris, 2006; Roelofs et al., 2011; Van Vlierberghe et al., 2010).

After the intervention, there was a significant decrease in most early maladaptive schemas in children except for the Enmeshment/Undeveloped Self. Similar reductions in early maladaptive schemas have been found in the few other studies in which Schema Therapy or Schema Therapy-based programs were implemented on children and adolescents (Alizadeh et al., 2015; Roelofs et al., 2016; Salehi et al., 2017; Saravi et al., 2020). The rather unexpected increase in the schema of Enmeshment/Undeveloped Self at post-test may be attributed to the fact that this schema is functional and adaptive in this age group (i.e., 9-13 years), because it

reflects the close bond and the intense emotional sharing between children and parents (Ghamkhar Fard et al., 2014; Rijkeboer & de Boo, 2010); this bond was strengthened during the implementation of the program.

In sum, these findings provide empirical support to the validity of the new program. The decreases seem to be the result of the implementation of the principles, tools, and techniques of this Schema Therapy-based prevention program, which specifically addresses early maladaptive schemas. In this program, children were educated to identify their emotions, core emotional needs, schema modes, and coping styles and to systematically work on them. This is the essence of a Schema Therapy-based program (Roelofs et al., 2011, 2013; Van Vlierberghe et al., 2007, 2010).

### *Children's Strengths and Psychopathological Symptoms*

Initially, it is important to note that the most frequently reported psychopathological symptoms or difficulties among children, as reported both by children and their parents, were Hyperactivity/Inattention, Conduct Problems, and Emotional Symptoms. The levels of these symptoms were low to moderate. These findings are in accordance with those of other studies worldwide (Brandenburg et al., 1990; Cury & Golfeto, 2003; Goodman et al., 2000; Holik et al., 2021) and in Greece in particular (Bibou-Nakou et al., 2001; Petanidou et al., 2014).

After the implementation of the program, there was a decrease in Emotional Symptoms, Peer Relationship Problems, and in the Total Score of difficulties as assessed by children. These findings are of value because children's self-reports of their difficulties, compared to parents' or teachers' reports, are considered as highly valid (Loose et al., 2020). The significant decrease in the Total Score of the Strengths and Difficulties Questionnaire is another important indicator of the effectiveness of the program, because the total score reflects mental health problems (Goodman et al., 2000). Existing research evidence indicates that children's early maladaptive schemas have significant links with psychopathological symptoms (e.g., Abdolazadeh et al., 2017; Alba & Calvete, 2019; Calvete, 2008; Calvete et al., 2013a; Ghamkhar Fard et al., 2014; Muris, 2006; Leung & Poon, 2001; Tariq et al., 2021; Tsouvelas et al., 2023; Van Wijk-Herbrink, et al., 2018; Yiğit, et al., 2018), therefore the decrease in the latter may be due, at least in part, to the decrease of the former. In addition, parents' participation –which is a strength of this prevention program– is likely to have contributed to children's positive outcomes, mainly through the reduction of parents' early maladaptive schemas (see next section).

Quite similarly, after the implementation of the program, there was a significant decrease, according to parents' reports, in children's Emotional Symptoms and in the Total Score of difficulties, as well as a significant increase in their Prosocial Behavior. These findings indicate that children and parents generally agreed regarding the positive effects of the program on the former. Parents did not

identify the decrease in Peer Relationship Problems, perhaps because they are “outsiders” as far as their children’s peer groups are concerned. However, they reported an increase in Prosocial Behavior, which is usually overt behavior, thus more easily observed by parents than by children themselves.

In sum, this new Schema Therapy-based program succeeded in reducing children’s emotional difficulties (i.e., anxious, depressive, and somatic symptoms) and social difficulties (i.e., in the peer group) and in increasing prosocial behavior. It is encouraging that there was a high degree of agreement between children and parents on the positive impact of the program on children’s mental health.

### *Parents’ Early Maladaptive Schemas*

Initially, it is important to note that the most frequently reported early maladaptive schemas among parents were Self-Sacrifice, Unrelenting Standards/Hypercriticalness, Approval-Seeking/Recognition-Seeking, Insufficient Self-Control/Self-Discipline, and Entitlement/Grandiosity. The levels of these schemas were rather low, whereas in Self-Sacrifice parents exhibited moderate levels. According to existing research, parents’ early maladaptive schemas are associated with dysfunctional parenting practices (Basso et al., 2019; Loose et al., 2020; Louis & Louis, 2015; Maçik et al., 2016; Sójta & Strzelecki, 2023; Young et al., 2003), early maladaptive schemas in their children (Gibson & Francis, 2019; Sundag et al., 2018; Zeynel & Uzer, 2020; Zonnevijlle & Hildebrand, 2019) and psychopathological symptoms in children (Gibson & Francis, 2019). Therefore, the reduction of these schemas in parents is of paramount importance.

After the implementation of the program, a significant reduction occurred in half of the early maladaptive schemas assessed: Emotional Deprivation, Mistrust/Abuse, Dependence/Incompetence, Enmeshment/Undeveloped Self, Subjugation, Insufficient Self-Control/Self-Discipline, Approval-Seeking/Recognition-Seeking, Punitiveness, and in the Total score. These findings justify the inclusion of parents in the program and provide support for the effectiveness of it. The psychoeducational group work enabled parents to identify their own and their children’s core emotional needs and their own schema modes and to work on ways to satisfy these needs. The fact that the satisfaction of core emotional needs runs contrary to the emergence of early maladaptive schemas may be one explanation for the reduction of the latter. Moreover, the content of the early maladaptive schemas that significantly subsided after the program is in line with the content of this program: parents experienced mutual support within the group, strengthening of their bond, free emotional expression, validation of their feelings, and secure experimentation with new behavioral styles (Farrell & Shaw, 2009).

However, it is important to note that three of the most frequently reported early maladaptive schemas, that is, Self-Sacrifice, Unrelenting Standards/Hypercriticalness, and Entitlement/Grandiosity, did not change after the

intervention. This finding should be considered in the future implementation of the new program. More sessions in the program may be required to specifically target such core schemas that are resistant to change.

### *Limitations and Suggestions for Future Research*

The main limitations of this study stem from the fact that it was conducted during the initial phases of the COVID-19 pandemic. As a result, the control group, which was assessed at pre-test, exhibited a high attrition rate and was excluded, the sample size was rather small, and although the program was conducted in-person before the onset of the pandemic, it had to be transferred on-line during the lockdown period. Therefore, future evaluation of the program should be done with a more rigorous experimental design including a control group and a follow-up assessment, with a larger and more representative sample, and with the same implementation mode all throughout the program. A more objective assessment of treatment fidelity should also be included. Nevertheless, the fact that the new psychoeducational prevention program can be implemented either in-person or on-line may be regarded as one of its main strengths.

The relatively small effect sizes of the change at post-test in all outcome variables may be attributed, at least in part, to the fact that the study was conducted in a nonclinical sample of children and parents, who had somewhat low mean scores on early maladaptive schemas and psychopathology and somewhat high scores in strengths before the intervention. However, it is important to note that such a psychoeducational prevention program –and not a therapeutic intervention as in most other relevant studies– resulted in statistically significant changes at post-test.

Another reason for the relatively small effect sizes may be the fact that the program was conducted during the COVID-19 pandemic, which may have influenced its implementation and outcome in various ways that could not be identified and controlled. Specifically, although the pre-test, which was conducted before the pandemic, showed low to moderate levels of early maladaptive schemas and psychopathological symptoms, these levels are likely to have risen during the pandemic (Urbańska & Słysz, 2023). Indeed, research evidence indicates that the well-being of children and parents significantly deteriorated during this period, worldwide and in Greece (e.g., Cachón-Zagalaz et al., 2020; Giannopoulou et al., 2022; Sancho et al., 2021). Therefore, the unprecedented global crisis of COVID-19 may have attenuated the positive impact of the new program on the participants.

### *Conclusion*

The contribution of this study was the development of an evidence-based and developmentally appropriate psychoeducational group program for children and their parents, based on Schema Therapy, with the aim of preventing children's

psychopathology. Up to date, there are very few studies on the evaluation of Schema Therapy programs for children and adolescents and, to our knowledge, there is no other group prevention program based on Schema Therapy for both children and their parents. Despite the disruption caused by the COVID-19 pandemic during the implementation of the program, the significant decreases in most early maladaptive schemas of children and in many early maladaptive schemas of parents, as well as the significant decreases in children's psychopathological symptoms and increases in their strengths (as assessed by themselves and their parents) support the validity and the utility of the new program. Further in-person and on-line implementation of the newly developed program in larger community samples of children and their parents and assessment of its effectiveness are needed.

### **Authors' Notes**

**Acknowledgement.** The research reported in this paper was supported by a doctorate scholarship granted to the first author by the State Scholarships Foundation of Greece.

**Conflict of Interest.** We have no known conflict of interest to disclose.

**Data availability statement:** The data are not openly available due to privacy/ethical restrictions but are available on reasonable request from the corresponding author.

### **References**

- Abdolahzadeh Rafi, M., Adibsereshki, N., & Hasanzadeh Aval, M. (2017). The mediating role of early maladaptive schemas in the relationships of emotional maltreatment and emotional disorders. *European Journal of Mental Health, 12*(1), 104–115. <https://doi.org/10.5708/EJMH.12.2017.1.7>
- Aghayousefi, A., & Amirpoor, B. (2014). Comparison of early maladaptive schemas in neurotic perfectionism and non-perfectionist middle school students. *Zahedan Journal of Research in Medical Sciences, 16*(5), 37–40. <https://brieflands.com/articles/zjrms-1571#Fulltext>
- Aggeli, K., Mastracha, P., & Laious, R. (in preparation). *The Greek adaptation of the Schema Inventory for Children.*
- Alaftar, I., & Uzer, T. (2022). Understanding intergenerational transmission of early maladaptive schemas from a memory perspective: Moderating role of overgeneral memory on adverse experiences. *Child Abuse & Neglect, 127*, 105539. <https://doi.org/10.1016/j.chiabu.2022.105539>

- Alba, J., & Calvete, E. (2019). Bidirectional relationships between stress, depressive symptoms, and cognitive vulnerabilities in adolescents. *Journal of Social and Clinical Psychology, 38*(2), 87–112. <https://doi.org/10.1521/jscp.2019.38.2.87>
- Alizadeh, A., Jomehri, F., & Kakavand, A. (2015). The effectiveness of schema therapy for children with cancer to improve depression symptoms. *Journal UMP Social Sciences and Technology Management, 3*(3), 618–622.
- Bach, B., Simonsen, E., Christoffersen, P., & Kriston, L. (2017). The Young Schema Questionnaire 3 Short-Form (YSQ-S3). *European Journal of Psychological Assessment, 33*(2), 134–143. <https://doi.org/10.1027/1015-5759/a000272>
- Basso, L. A., Fortes, A. B., Maia, C. P., Steinhorst, E., & Wainer, R. (2019). The effects of parental rearing styles and early maladaptive schemas in the development of personality: A systematic review. *Trends in Psychiatry and Psychotherapy, 41*(3), 301–313. <http://dx.doi.org/10.1590/2237-6089-2017-0118>
- Bibou-Nakou, I., Kiosseoglou, G., & Stogiannidou, A. (2001). Strengths and difficulties of school-aged children in the family context. *Psychology: The Journal of Hellenic Psychological Society, 8*(4), 506–525. <https://ejournals.e-publishing.ekt.gr/index.php/psychology/article/view/24129/20202>
- Bishop, A., Younan, R., Low, J., & Pilkington, P. D. (2021). Early maladaptive schemas and depression in adulthood: A systematic review and meta-analysis. *Clinical Psychology & Psychotherapy, 29*(1), 111–130. <https://doi.org/10.1002/cpp.2630>
- Brandenburg, N. A., Friedman, R. M., & Silver, S. E. (1990). The epidemiology of childhood psychiatric disorders. Prevalence findings from recent studies. *Journal of the American Academy of Child and Adolescent Psychiatry, 29*(1), 76–83. <https://doi.org/10.1097/00004583-199001000-00013>
- Cachón-Zagalaz, J., Sánchez-Zafra, M., Sanabrias-Moreno, D., González-Valero, G., Lara-Sánchez, A. J., & Zagalaz-Sánchez, M. L. (2020). Systematic review of the literature about the effects of the COVID-19 pandemic on the lives of school children. *Frontiers in Psychology, 11*, 569348. <https://doi.org/10.3389/fpsyg.2020.569348>
- Calvete, E. (2008). Justification of violence and grandiosity schemas as predictors of antisocial behavior in adolescents. *Journal of Abnormal Child Psychology, 36*(7), 1083–1095. <https://doi.org/10.1007/s10802-008-9229-5>
- Calvete, E., & Orue, I. (2010). Cognitive schemas and aggressive behavior in adolescents: The mediating role of social information processing. *The Spanish Journal of Psychology, 13*(1), 190–201. <https://doi.org/10.1017/s113874160003772>
- Calvete, E., & Orue, I. (2012). Social information processing as a mediator between cognitive schemas and aggressive behavior in adolescents. *Journal of Abnormal Child Psychology, 40*(1), 105–117. <https://doi.org/10.1007/s10802-011-9546-y>
- Calvete, E., Orue, I., & Hankin, B. L. (2013a). Early maladaptive schemas and social anxiety in adolescents: The mediating role of anxious automatic thoughts.

- Journal of Anxiety Disorders*, 27(3), 278–288. <https://doi.org/10.1016/j.janxdis.2013.02.011>
- Chan, E. W. L., & Tan, H. J. R. (2020). Positive psychology couple schema therapy: A new model of couple therapy focusing on reigniting couple attraction via schema therapy and positive psychology. *Journal for ReAttach Therapy and Developmental Diversities*, 2(2), 61–69. <https://jrtd.com/index.php/journal/article/view/20>
- Cohen, J. (1992). A power primer. *Psychological Bulletin*, 112(1), 155–159. <https://doi.org/10.1037/0033-2909.112.1.155>
- Cury, C. R., & Golfeto, J. H. (2003). Strengths and Difficulties Questionnaire (SDQ): A study of school children in Ribeirão Preto. *Brazilian Journal of Psychiatry*, 25(3), 139–145. <https://doi.org/10.1590/S1516-44462003000300005>
- Dickhaut, V., & Arntz, A. (2014). Combined group and individual schema therapy for borderline personality disorder: A pilot study. *Journal of Behavior Therapy and Experimental Psychiatry*, 45(2), 242–251. <https://doi.org/10.1016/j.jbtep.2013.11.004>
- Farrell, J. M., Reiss, N., & Shaw, I. A. (2014). *The Schema Therapy clinician's guide: A complete resource for building and delivering individual, group and integrated schema mode treatment programs*. Wiley Blackwell.
- Farrell, J. M., Shaw, I. A., & Webber, M. A. (2009). A schema-focused approach to group psychotherapy for outpatients with borderline personality disorder: A randomized controlled trial. *Journal of Behavior Therapy and Experimental Psychiatry*, 40(2), 317–328. <https://doi.org/10.1016/j.jbtep.2009.01.002>
- Field, A. P. (2018). *Discovering statistics using IBM SPSS Statistics* (5th ed.). Sage.
- Geerdink, M., Jongman, E., & Scholing, A. (2012). Schema therapy in adolescents. In M. van Vreeswijk, J. Broersen, & M. Nadort (Eds.), *The Wiley-Blackwell handbook of schema therapy: Theory, research, and practice* (pp. 391–396). Wiley-Blackwell.
- Ghamkhar Fard, Z., Schneider, S., Hudson, J. L., Habibi, M., Pooravari, M., & Heidari, Z. H. (2014). Early maladaptive schemas as predictors of child anxiety: The role of child and mother schemas. *International Journal of Applied Behavioral Sciences*, 1(2), 9–18. <https://doi.org/10.22037/ijabs.v1i2.7564>
- Giannopoulou, I., Efstathiou, V., Korkoliakou, P., Triantafyllou, G., Smyrnis, N., & Douzenis, A. (2022). Mental health of adolescents amidst preparation for university entrance exams during the second pandemic-related lockdown in Greece. *Journal of Affective Disorders Reports*, 8, 100339. <https://doi.org/10.1016/j.jadr.2022.100339>
- Gibson, M., & Francis, A. J. P. (2019). Intergenerational transfer of early maladaptive schemas in mother-daughter dyads, and the role of parenting. *Cognitive Therapy and Research*, 43(4), 737–747. <https://doi.org/10.1007/s10608-018-09994-3>
- Gong, J., & Chan, R. C. K. (2018). Early maladaptive schemas as mediators between childhood maltreatment and later psychological distress among Chinese

- college students. *Psychiatry Research*, 259, 493–500. <https://doi.org/10.1016/j.psychres.2017.11.019>
- Goodman, R. (1997). The Strengths and Difficulties Questionnaire: A research note. *The Journal of Child Psychology and Psychiatry*, 38(5), 581–586. <https://doi.org/10.1111/j.1469-7610.1997.tb01545.x>
- Goodman, R., Ford, T., Simmons, H., Gatward, R., & Meltzer, H. (2000). Using the Strengths and Difficulties Questionnaire (SDQ) to screen for child psychiatric disorders in a community sample. *The British Journal of Psychiatry*, 177(6), 534–539. <https://doi.org/10.1192/bjp.177.6.534>
- Hajimirab, B., Rahimi, C., & Mohammadi, N. (2016). Prediction of anxiety based on maladaptive schemas in children. *European Online Journal of Natural and Social Sciences*, 5(1), 108–118. <https://european-science.com/eojnss/article/view/3031>
- Holik, D., Kribl, M., Milostic-Srb, A., & Nujic, D. (2021). Epidemiology of youth mental health problems from the area of Osijek using Strengths and Difficulties Questionnaire (SDQ). *Archives of Psychiatry Research*, 57(1), 61–68. <https://doi.org/10.20471/may.2021.57.01.06>
- Janovsky, T., Rock, A. J., Thorsteinsson, E. B., Clark, G. I., & Murray, C. V. (2020). The relationship between early maladaptive schemas and interpersonal problems: A meta-analytic review. *Clinical Psychology & Psychotherapy*, 27(3), 408–447. <https://doi.org/10.1002/cpp.2439>
- Laious, R., Galanaki, E., Aggeli, K., Koutrafouris, V., Marini, K., & Sintila, I. (2020, September). *How to connect with self and others: A prevention program based on Schema Therapy for children and their parents in school settings*. Symposium at the 50th European Association of Behavioural and Cognitive Therapies, Athens.
- Laious, R., Galanaki, E., Aggeli, K., Tzavara, Ch., Argalia, E., Koutrafouris, V., Marini, K., Bakourini, D., & Sintila, I. (2022, June). *How to connect with self and others: A prevention program based on Schema Therapy for children and their parents in school settings*. Symposium at the 8th biennial Conference of the International Society of Schema Therapy, Copenhagen.
- Leung, P. W. L., & Poon M. W. L. (2001). Dysfunctional schemas and cognitive distortions in psychopathology: A test of the specificity hypothesis. *Journal of Child Psychology and Psychiatry*, 42(6), 755–765. <https://doi.org/10.1111/1469-7610.00772>
- Lobbetael, J., van Vreeswijk, M., & Arntz, A. (2007). Shedding light on schema modes: A clarification of the mode concept and its current research status. *Netherlands Journal of Psychology*, 63(3), 76–85. <https://doi.org/10.1007/BF03061068>
- Lockwood, G., & Shaw, I. (2012). Schema therapy and the role of joy and play. In M. van Vreeswijk, J. Boersen, & M. Nadort (Eds.), *The Wiley-Blackwell handbook of schema therapy: Theory, research, and practice* (pp. 209–227). Wiley.

- Loose, C. (2011). *Motivational concept: Six stage schema-and-mode-driven behavior therapy for children and adolescents*. [www.schematherapy-for-children.de](http://www.schematherapy-for-children.de)
- Loose, C., Graaf, P., & Zarbock, P. (2013). Child-related techniques and procedures in schema therapy with children and adolescents. In C. Loose, P. Graaf, & P. Zarbock (Eds.), *Schematherapie mit Kindern und Jugendlichen*. Beltz.
- Loose, C., Graaf, P., Zarbock, G., & Holt, R. A. (Eds.). (2020). *Schema therapy with children and adolescents: A practitioner's guide*. Pavilion Publishing.
- Louis, J. P., & Louis, K. D. (2015). *Good enough parenting: An in-depth perspective on meeting core emotional needs and avoiding exasperation*. Morgan James Publishing.
- Louis, J. P., Ortiz, V., Barlas, J., Lee, J. S., Lockwood, G., Chong, W. F., McDonald Louis, K., & Sim, P. (2021). The Good Enough Parenting early intervention schema therapy based program: Participant experience. *Plos ONE* 16(1): e0243508. <https://doi.org/10.1371/journal.pone.0243508>
- Lumley, M. N., & Harkness, K. L. (2007). Specificity in the relations among childhood adversity, early maladaptive schemas, and symptom profiles in adolescent depression. *Cognitive Therapy and Research*, 31(5), 639–657. <https://doi.org/10.1007/s10608-006-9100-3>
- Maçık, D., Chodkiewicz, J., & Bielicka, D. (2016). Trans-generational transfer of early maladaptive schemas—A preliminary study performed on a nonclinical group. *Current Issues in Personality Psychology*, 4(3), 132–145. <https://doi.org/10.5114/cipp.2016.60411>
- Malogiannis, I. A., Aggeli, A., Garoni, D., Tzavara, Ch., Michopoulos, I., Pehlivanidis, A., Kalantzi-Azizi, A., & Papadimitriou, G. N. (2018). Validation of the Greek version of Young Schema Questionnaire Short Form 3: Internal consistency reliability and validity. *Psychiatriki, the Journal of the Hellenic Psychiatric Association*, 29(3), 220–230. <https://doi.org/10.22365/jpsych.2018.293.220>
- McCarthy, M. C., & Lumley, M. N. (2012). Sources of emotional maltreatment and the differential development of unconditional and conditional schemas. *Cognitive Behaviour Therapy*, 41(4), 288–297. <https://doi.org/10.1080/16506073.2012.676669>
- Montgomery-Graham, S. (2016). DBT and schema therapy for borderline personality disorder: Mentalization as a common factor. *Journal of Contemporary Psychotherapy*, 46(1), 53–60. <https://doi.org/10.1007/s10879-015-9309-0>
- Mousavi, S. E., Low, W. Y., & Hashim A. H. (2016). The relationships between perceived parental rearing style and anxiety symptoms in Malaysian adolescents: The mediating role of early maladaptive schemas. *Journal of Depression and Anxiety*, S2, 009. <https://doi.org/10.4172/2167-1044.s2-009>
- Muris, P. (2006). Maladaptive schemas in non-clinical adolescents: Relations to perceived parental rearing behaviours, Big Five personality factors and psychopathological symptoms. *Clinical Psychology and Psychotherapy*, 13(6), 405–413. <https://doi.org/10.1002/cpp.506>

- Nordahl, D., Høifødt, R. S., Bohne, A., Landsem, I. P., Wang, C. E. A., & Thimm, J. C. (2019). Early maladaptive schemas as predictors of maternal bonding to the unborn child. *BMC Psychology*, 7(1), 23. <https://doi.org/10.1186/s40359-019-0297-9>
- Palmer, E. J. (2000). Perceptions of parenting, social cognition and delinquency. *Clinical Psychology and Psychotherapy*, 7(4), 303–309. [http://dx.doi.org/10.1002/1099-0879\(200010\)7:4%3C303::AID-CPP263%3E3.0.CO;2-K](http://dx.doi.org/10.1002/1099-0879(200010)7:4%3C303::AID-CPP263%3E3.0.CO;2-K)
- Peeters, N., van Passel, B., & Krans, J. (2022). The effectiveness of schema therapy for patients with anxiety disorders, OCD, or PTSD: A systematic review and research agenda. *British Journal of Clinical Psychology*, 61(3), 579–597. <https://doi.org/10.1111/bjc.12324>
- Petanidou, D., Giannakopoulos, G., Tzavara, Ch., Dimitrakaki, C., Kolaitis, G., & Tountas, Y. (2014). Adolescents' multiple, recurrent subjective health complaints: Investigating associations with emotional/behavioural difficulties in a cross-sectional, school-based study. *Child and Adolescent Psychiatry and Mental Health*, 8(1), 3. <https://doi.org/10.1186/1753-2000-8-3>
- Pilkington, P., Younan, R., & Bishop, A. (2021). Early maladaptive schemas, suicidal ideation, and self-harm: A meta-analytic review. *Journal of Affective Disorders Reports*, 3, 100051. <https://doi.org/10.1016/j.jadr.2020.100051>
- Rijkeboer, M. M., & de Boo, G. M. (2010). Early maladaptive schemas in children: Development and validation of the Schema Inventory for Children. *Journal of Behavior Therapy and Experimental Psychiatry*, 41(2), 102–109. <https://doi.org/10.1016/j.jbtep.2009.11.001>
- Roediger, E., Stevens, B. A., & Brockman, R. (2018). *Contextual schema therapy: An integrative approach to personality disorders, emotional dysregulation, and interpersonal functioning*. Context Press.
- Roelofs, J., Lee, C., Rujiten, T., & Lobbstael, J. (2011). The mediating role of early maladaptive schemas in the relation between quality of attachment relationships and symptoms of depression in adolescents. *Behavioural and Cognitive Psychotherapy*, 39(4), 471–479. <https://doi.org/10.1017/s1352465811000117>
- Roelofs, J., Muris, P., & Lobbstael, J. (2016). Acting and feeling like a vulnerable child, an internalized “bad” parent, or a healthy person: The assessment of schema modes in non-clinical adolescents. *Journal of Personality Disorders*, 30(4), 469–482. [https://doi.org/10.1521/pedi\\_2015\\_29\\_209](https://doi.org/10.1521/pedi_2015_29_209)
- Roelofs, J., Onckels, L., & Muris, P. (2013). Attachment quality and psychopathological symptoms in clinically referred adolescents: The mediating role of early maladaptive schema. *Journal of Child and Family Studies*, 22(3), 377–385. <https://doi.org/10.1007/s10826-012-9589-x>
- Rosenthal, R. (1994). Science and ethics in conducting, analyzing, and reporting psychological research. *Psychological Science*, 5(3), 127–134. <https://doi.org/10.1111/j.1467-9280.1994.tb00646.x>
- Rusinek, S., Charbonnier, E., Boudoukha, A. H., Graziani, P., & Dafonseca, D. (2013). Early maladaptive schemas among children: A new way to screen for

- depressed children? *Psicoterapia Cognitiva e Comportamentale*, 19(2), 157–168. <https://univ-angers.hal.science/hal-03355850>
- Sabzi, N., Bijari, A. F., & Khosravi, Z. (2022). The effectiveness of group schema therapy-based parenting education of mothers on modifying maladaptive schemas of the child and improving the quality of the parent-child relationship. *Practice in Clinical Psychology*, 10(1), 33–44. <http://doi.10.32598/jpcp.10.1.798.1>
- Salehi, S., ParsaSirat, N., & Motaghian, L. (2017). First-grade students' effectiveness of early maladaptive schema therapy on behavioral syndromes among first-grade students. *Journal of Socialomics*, 6(2), 1000193. <http://doi.org/10.4172/2167-0358.1000193>
- Sancho, N. B., Mondragon, N. I., Santamaria, M. D., & Munitis, A. E. (2021). The well-being of children in lock-down: Physical, emotional, social and academic impact. *Children and Youth Services Review*, 127, 106085. <https://doi.org/10.1016/j.childyouth.2021.106085>
- Sanetti, L. M. H., Cook, B. G., & Cook, L. (2021). Treatment fidelity: What it is and why it matters. *Learning Disabilities: Research & Practice*, 36(1), 5–11. <https://doi.org/10.1111/ldrp.12238>
- Saravi, S. R., Hassani, F., Arshadi, F. K., Farzad, V., & Sepahmansour, M. (2020). Effectiveness of group schema therapy on eating attitude and self-regulation in overweight adolescent females with binge eating disorder. *Avicenna Journal of Neuro Psycho Physiology*, 7(1), 20–28. <http://ajnpp.umsha.ac.ir/article-1-307-en.html>
- Shaughnessy, J. J., Zechmeister, E. B., & Zechmeister, J. S. (2015). *Research methods in psychology* (10th ed.). McGraw-Hill.
- Simeon-DiFrancesco, C., Eckhard, R., & Stevens, B. A. (2015). *Schema therapy with couples: A practitioner's guide to healing relationships*. Wiley-Blackwell.
- Simmons, J., Cooper, M. J., Drinkwater, J., & Stewart, A. (2006). Cognitive schemata in depressed adolescent girls and their mothers. *Behavioural and Cognitive Psychotherapy*, 34(2), 219–232. <https://doi.org/10.1017/S1352465805002766>
- Skewes, A. S., Samson, R. A., Simpson, S. G., & van Vreeswijk, M. (2015). Short-term group schema therapy for mixed personality disorders: A pilot study. *Frontiers in Psychology*, 5, 1592. <https://doi.org/10.3389/fpsyg.2014.01592>
- Sójtá, K. & Strzelecki, D. (2023). Early maladaptive schemas and their impact on parenting: Do dysfunctional schemas pass generationally? A systematic review. *Journal of Clinical Medicine*, 12(4), 1263. <https://doi.org/10.3390/jcm12041263>
- Stallard, P. (2007). Early maladaptive schemas in children: Stability and differences between a community and a clinic referred sample. *Clinical Psychology and Psychotherapy*, 14(1), 10–18. <https://doi.org/10.1002/cpp.511>
- Sundag, J., Zens, C., Ascone, L., Thome, S., & Lincoln, T. M. (2018). Are schemas passed on? A study on the association between early maladaptive schemas in parents and their offspring and the putative translating mechanisms.

- Behavioural and Cognitive Psychotherapy*, 46(6), 738–753. <https://doi.org/10.1017/S1352465818000073>
- Tariq, A., Reid, C., & Chan, S. W. Y. (2021). A meta-analysis of the relationship between early maladaptive schemas and depression in adolescence and young adulthood. *Psychological Medicine*, 51(8), 1233–1248. <https://doi.org/10.1017/S0033291721001458>
- Taylor, C. D. J., & Arntz, A. (2016). Schema therapy. In A. M. Wood & J. Johnson (Eds.), *The Wiley-Blackwell handbook of positive clinical psychology* (pp. 461–476). Wiley-Blackwell.
- Tsouvelas, G., Chondrokouki, M., Antoniou, X., & Nikolaidis, G. (2023). Early maladaptive schemas and symptoms of psychopathology in children in residential care. *Psychiatriki, The journal of the Hellenic Psychiatric Association* (on-line first). <https://doi.org/10.22365/jpsych.2023.007>
- Turner, H. M., Rose, K. S., & Cooper, M. J. (2005). Schema and parental bonding in overweight and nonoverweight female adolescents. *International Journal of Obesity*, 29(4), 381–387. <https://doi.org/10.1038/sj.ijo.0802915>
- Urbańska, J., & Słysz, A. (2023). The role of early maladaptive schemas in the change in general mental health and well-being during the COVID-19 coronavirus pandemic. *Journal of Evidence-Based Psychotherapies*, 23(1), 153–165. <https://doi.org/10.24193/jebp.2023.1.7>
- Van Genderen, H., Rijkeboer, M., & Arntz, A. (2012). Theoretical model: Schemas, coping styles, and modes. In M. van Vreeswijk, J. Boersen, & M. Nadort (Eds.), *The Wiley-Blackwell handbook of schema therapy: Theory, research, and practice* (pp. 27–40). Wiley Blackwell.
- Van Vlierberghe, L., Braet, C., Bosmans, G., Rosseel, Y., & Bögels, S. (2010). Maladaptive schemas and psychopathology in adolescence: On the utility of Young's schema theory in youth. *Cognitive Therapy and Research*, 34(4), 316–332. <https://doi.org/10.1007/s10608-009-9283-5>
- Van Vlierberghe, L., Timbremont, B., Braet, C., & Basile, B. (2007). Parental schemas in youngsters referred for antisocial behavior problems demonstrating depressive symptoms. *The Journal of Forensic Psychiatry & Psychology*, 18(4), 515–533. <https://doi.org/10.1080/14789940701515442>
- Van Wijk-Herbrink, M. F., Bernstein, D. P., Broers, N. J., Roelofs, J., Rijkeboer, M. M., & Arntz, A. (2018). Internalizing and externalizing behaviors share a common predictor: The effects of early maladaptive schemas are mediated by coping responses and schema modes. *Journal of Abnormal Child Psychology*, 46(5), 907–920. <https://doi.org/10.1007/s10802-017-0386-2>
- Yiğit, İ., Kılıç, H., Guzey Yiğit, M., & Çelik, C. (2021). Emotional and physical maltreatment, early maladaptive schemas, and internalizing disorders in adolescents: A multi-group path model of clinical and non-clinical samples. *Current Psychology*, 40(1), 1356–1366. <https://doi.org/10.1007/s12144-018-0068-4>
- Young, J. E., & Brown, G. (2003). *Young Schema Questionnaire*. Cognitive Therapy Center of New York.

- Young, J. E., & First, M. B. (2003). *Schema mode listing*. Schema Therapy Institute. [www.schematherapy.com/id72.htm](http://www.schematherapy.com/id72.htm)
- Young, J. E., Klosko, J. S., & Weishaar, M. E. (2003). *Schema therapy: A practitioner's guide*. Guilford Press.
- Zafiropoulou, M., Avagianou, P.-A., & Vassiliadou, S. (2014). Parental bonding and early maladaptive schemas. *Journal of Psychological Abnormalities in Children*, 3(1), 1000110. <https://doi:10.4172/2329-9525.1000110>
- Zeynel, Z., & Uzer, T. (2020). Adverse childhood experiences lead to trans-generational transmission of early maladaptive schemas. *Child Abuse & Neglect*, 99, 104235. <https://doi.org/10.1016/j.chiabu.2019.104235>
- Zonnevjlle, M., & Hildebrand, M. (2019). Like parent, like child? Exploring the association between early maladaptive schemas of adolescents involved with Child Protective Services and their parents. *Child & Family Social Work*, 24(2), 190–200. <https://doi.org/10.1111/cfs.12602>

---

## PSYCHOMETRIC PROPERTIES OF THE ITALIAN VERSION OF THE INTERPERSONAL SENSITIVITY MEASURE (IPSM)

---

Compare Lisa<sup>1</sup>, Cansu Alsancak-Akbulut<sup>1,2\*</sup>, Giovanni Tumminaro<sup>1</sup>, Martina Smorti<sup>1</sup>, Olivia Bernini<sup>3</sup>, Francesca Ravagli<sup>1</sup>, Carmen Berrocal Montiel<sup>1</sup>

---

<sup>1</sup> Department of Surgical, Medical and Molecular Pathology and Critical Care, University of Pisa, Pisa, Italy

<sup>2</sup> Department of Psychology, Ankara University, Ankara, Turkey

<sup>3</sup> Counselling Services, University of Pisa, Pisa, Italy

---

### Abstract

The Interpersonal Sensitivity Measure (IPSM) is used to assess interpersonal sensitivity. This study explored the factor structure, internal consistency, and criterion validity of the Italian version of the IPSM (IPSM-It) in non-clinical emerging adults. 374 participants aged between 18 and 31 years (64.4% female;  $M = 21.96$ ,  $SD = 2.91$ ) were included in the study. They completed the IPSM, the Beck Depression Inventory-I, the Beck Anxiety Inventory, the State-Trait Anger Expression Inventory-II, and the Satisfaction with Life Scale. Confirmatory factor analysis indicated that the original structure of the measure did not fit the data well. An exploratory factor analysis was also conducted and the results supported a 27-item version of the IPSM and a three-factor structure (Interpersonal Worry and Dependency, Low Self-Esteem, and Unassertive Interpersonal Behavior). The IPSM-It showed good internal consistency and criterion validity. The IPSM-It appeared to be a reliable and valid measure for assessing IPS in Italian culture.

**Keywords:** interpersonal sensitivity, reliability, validity, assessment, emerging adults.

Interpersonal sensitivity (IPS), recently called “sensitivity to personal rejection” (Mohammadian et al., 2017) and “interpersonal rejection sensitivity” (Harb et al., 2002), was defined as an “*undue and excessive awareness of, and sensitivity to, the behavior and feelings of others*” (Boyce & Parker, 1989, p. 342).

---

\* Correspondence concerning this article should be addressed to Cansu Alsancak-Akbulut, Department of Surgical, Medical and Molecular Pathology and Critical Care, University of Pisa, Via Savi 10, 56126 Pisa, Italy.  
E-mail: cakbulut@ankara.edu.tr

IPS is characterized as non-assertive behavior, vigilance about others' reactions, lower self-worth, and oversensitivity to others' behaviors, statements, and social feedback. The perception of interpersonal rejection and frequent misunderstanding of ambiguous social signals may result in discomfort and avoidance in social contexts. This also represents a risk factor for the development of several mental health problems, including depression (Boyce et al., 1992; Masillo et al., 2014; You et al., 2020) and social anxiety (Mohammadian et al., 2017).

The Interpersonal Sensitivity Measure (IPSM) is a 36-item self-report instrument developed by Boyce and Parker (1989) to assess IPS. Boyce and Parker (1989) conceptualized IPS as a multidimensional construct, including interpersonal awareness, need for approval, separation anxiety, fragile inner self, and timidity. *Interpersonal Awareness* reflects the tendency to be overly conscious in interactions with others (Boyce and Parker, 1989). High scores in this domain indicate a heightened vigilance of other's behavior, over concerns about other's responses as well as high levels of apprehension in interpersonal contexts. The *Need for Approval* dimension reflects the extent to which individuals prioritize others' needs over their own to please others (Boyce and Parker, 1989). Items in this factor assess the desire to please others, seek social approval, and maintain harmonious relationships in which only pleasant emotions occur. The *Separation Anxiety* domain refers to the degree of anxiety experienced when there is a separation from significant others, in line with Bowlby's attachment theory (1977). Higher levels in this domain indicate heightened sensitivity and concerns about any threat of damaging or losing significant interpersonal bonds. The *Fragile Inner Self* reflects self-esteem and self-worth domains, with high scores indicating the belief of being flawed and unlikeable. In particular, items in this domain assess an individual's concerns about disapproval and being rejected.

Finally, Boyce and Parker's (1989) conceptualization of IPS includes the *Timidity* dimension. It should be highlighted that, even though labelled "timidity", this dimension does not assess shyness phenomenology. The *Timidity* dimension of the IPS reflects a lack of ability to act assertively in interpersonal contexts. Indeed, items reflect the tendency to use a passive communication style and behave in a way that avoids conflicts in social interactions at the expense of one's feelings and needs. Although unassertiveness is closely related to social anxiety, these constructs are not equivalent. While social anxiety refers to enhanced physiological and emotional responses to social contexts, unassertiveness has been conceptualized as a behavioral strategy to avoid negative evaluations of others (Swee et al., 2018). Thus, unassertiveness may be viewed as a subgroup of the common fears of individuals with social anxiety (e.g., Swee et al., 2018).

Some studies examined the psychometric properties of the IPSM across different samples, including undergraduate students (Dogan & Sapmaz, 2012; Mohammadian et al., 2017; You et al., 2020), healthy adults (Lee et al., 2013), and clinical samples (Harb et al., 2002; Masillo et al., 2014). Some of these studies confirmed the five-factor structure of the IPSM (Mohammadian et al., 2017; You et al., 2020; Lee et al., 2013). Yet, Lee et al. (2013) used different names to label the five factors of the Korean version, since the factors had a different item composition as compared to Boyce and Parker's (1989) version. Some other studies found a three-factor structure (i.e., interpersonal worry and dependency, low self-esteem, and unassertive interpersonal behavior) after deleting some items (Dogan & Sapmaz, 2012; Harb et al., 2002).

Previous research also raised doubts about the internal consistency and construct validity of the "Need for Approval" dimension. In particular, Cronbach's alpha coefficients for this dimension ranged from .40 to .73 (Harb et al., 2002; You et al., 2020; Lee et al., 2013), and some findings suggested that several items of this dimension (i.e., items 6, 13, and 20) should be reversed for scoring since they were positively correlated with high self-esteem (Harb et al., 2002; Dogan & Sapmaz, 2012).

Masillo et al. (2014) adapted the 36-item IPSM to Italian and explored its internal consistency and concurrent validity in a sample of emerging adults and adolescents who have a high risk for psychosis. However, they did not investigate the factorial structure of the Italian version. Therefore, the purpose of this study was to further investigate the psychometric properties of the Italian version of IPSM (IPSM-It) in a non-clinical sample of Italian emerging adults. In particular, this study focused on the factorial structure, internal consistency, and criterion validity (i.e., the associations with measures of anxiety, depression, anger, and life satisfaction) of the IPSM-It.

## **Method**

### *Participants*

Table 1 shows the socio-demographic characteristics of the sample. The sample included 374 emerging adults, aged between 18 and 31 years ( $M = 21.96$ ;  $SD = 2.91$ ). Participants were predominantly female (64.4%) and currently engaged in a romantic relationship (61.8%). Most of the participants (88.5%) were either college students or graduated from college. 11.5% of the sample had a high school level of education. Lastly, 68.4% of the sample was unemployed.

**Table 1.** Socio-demographic characteristics of the sample.

	Range	M-SD
<b>Age</b>	18-31	21.96 - 2.91
	<b>n</b>	<b>%</b>
<b>Gender</b>		
Female	241	64.4
Male	131	35.0
<b>Romantic relationship status</b>		
Engaged	93	24.9
Not engaged	231	61.8
<b>Education</b>		
High school	43	11.5
College students or graduated	331	88.5
<b>Employment</b>		
Yes	118	31.5
No	256	68.4

### Procedure

The present study was approved by the Committee on Bioethics of the University of Pisa (nr 6/2018). Recruitment took place in university halls before lectures or in public libraries in the provinces of Florence and Pisa. Participation was voluntary and did not include any form of compensation. Participants were informed about the purpose, anonymity, and confidentiality. All the participants filled in a questionnaire package in a paper-pencil format (described in detail in the following section, “Measures”). Self-report questionnaires following the socio-demographic information were presented in three randomly ordered packages, to reduce the risk of possible distortions in the answers related to the order of presentation.

### Measures

*Interpersonal Sensitivity.* The Interpersonal Sensitivity Measure (IPSM; Boyce & Parker, 1989; Italian version by Masillo et al., 2014) includes 36 items rated on a 4-point Likert scale ranging from 1 (*Very unlike me*) to 4 (*Very like me*). The measure is composed of five subscales: interpersonal awareness, need for approval, separation anxiety, timidity, and fragile inner-self. Higher scores indicate greater interpersonal sensitivity. Internal consistency for the total score was 0.86 in depressed patients and 0.85 in a non-clinical student sample (Boyce & Parker, 1989).

*Depression.* The Beck Depression Inventory-I (BDI-I; Beck et al., 1961; Italian version by Scilligo et al., 1983) was used to measure depressive symptoms that occurred in the last week. This questionnaire includes 21 items rated with a graded series of four descriptive statements of increasing severity. Higher scores correspond to higher levels of depression. The instrument showed a high internal

consistency both in clinical and non-clinical samples and a good concurrent validity with other measures of depressive symptoms (Beck et al., 1988a). In the present study, Cronbach's alpha of the BDI-I was .86.

*Anxiety.* The Beck Anxiety Inventory (BAI; Beck et al. 1988b; Italian version by Sica & Ghisi, 2007) includes 21 items measuring anxiety-related symptoms in the last two weeks. Items are rated on a 4-point Likert scale. Higher scores indicate higher levels of anxiety. Previous research demonstrated the internal consistency, test-retest reliability, and ability of the scale to discriminate between clinical and non-clinical samples (Beck et al., 1988b). In the present study, Cronbach's alpha of the BAI was .89.

*Anger Expression and Control.* The State-Trait Anger Expression Inventory-II (STAXI-II; Spielberger, 2010; Italian version by Comunian, 2004) was used to measure the expression and control of anger. This self-report measure assesses both the amount of anger that individuals experience at the time of examination (State Anger) and their general tendency towards anger (Trait Anger). For this study, only the Trait Anger has been employed, which consists of 31 items that participants were required to rate on a Likert scale ranging from 1 (*not at all*) to 4 (*very much so*). The Trait Anger is divided into four subscales, which measure different aspects of anger expression and control: Anger Expression-Out (AE-O) measures the tendency to frequently engage in violent or aggressive behavior as a consequence of anger; Anger Expression-In (AE-I) indicates the propensity to experience intense angry feelings that are not translated in external actions; Anger Control-Out (AC-O) assesses how frequently the individual actively avoids to act out on behalf of his angry feelings; and lastly, Anger Control-In (AC-I) indicates the frequency of attempts to cool down and relax, instead of perpetuating internal thoughts and feelings of anger. High scores on the two Expression subscales indicate frequent aggressive behavior (AE-O) or frequent experiences of internal anger (AE-I), whereas high scores on the Control subscales denote more intense efforts to calm down (AC-I) or to avoid becoming aggressive (AC-O). In the present study, Cronbach alpha coefficients of the subscales ranged from .63 to .87.

*Life Satisfaction.* The Satisfaction with Life Scale (SWLS; Diener et al., 1985; Italian version by Di Fabio & Busoni, 2009) was used to assess perceived global life satisfaction. This questionnaire consists of 5 items, rated on a 7-point Likert scale ranging from 1 (*never true*) to 7 (*always true*). Higher scores indicate higher levels of life satisfaction. In the present study, Cronbach's alpha of the SWLS was .86.

### *Statistical Analyses*

A confirmatory factor analysis (CFA) was performed to determine the fit of the original factor structure explored by Boyce and Parker (1989) to the data of this study. Specifically, CFA with maximum likelihood estimation and covariance

matrices were used. The adequacy of the five-factor model to the data was determined by using several a priori test statistics: ratios of chi-square to its degrees of freedom ( $\chi^2/df$ ) lower than 3, comparative fit index (CFI), Tucker Lewis Index (TLI), and Goodness of Fit Index (GFI) equal to or greater than .90, and root mean square error of approximation (RMSEA) and Standardized Root Mean Squared Residual (SRMR) equal to or lower than .05 (Byrne, 2016). Based on the results of CFA, an exploratory factor analysis (EFA) was also conducted. The principal axis factor (PAF) with varimax rotation was used to determine the IPSM-It factor structure. Internal consistency was assessed using Cronbach's alpha. Criterion validity was evaluated by calculating Pearson's correlation coefficients between the IPSM-It and measures of depression, anxiety, anger, and life satisfaction.

## **Results**

### *Descriptive Statistics and Inter-Item Correlations*

Descriptive statistics for each item were calculated. Item means ranged from 1.80 to 3.56, and their standard deviations ranged from 0.70 to 1.04. Only two items differed slightly from the normal distribution: Item 4 had a platykurtic distribution (with a kurtosis value of  $-1.10$ ) and Item 18 had a leptokurtic distribution (with a kurtosis value of  $1.04$ ). Moreover, Item 18 also showed a skewness value of  $-1.22$ , indicating an asymmetric distribution. The inter-item correlation matrix of IPSM-It was obtained to explore multicollinearity. Pearson correlation coefficients ranged from weak to moderate with no value greater than 0.8, suggesting no item redundancy.

### *Confirmatory Factor Analysis*

CFA with maximum likelihood estimation and covariance matrices were used to test whether the original five-factor structure fits the data of this study. Results showed that the model did not fit the data ( $\chi^2(584, N = 374) = 1935.072$ ,  $\chi^2/df = 3.13$ , CFI = .67, TLI = .64, GFI = .74, RMSEA = .08, SRMR = .10). All factor loadings except Item 13 and Item 20 on their own factors were significant, therefore the items with non-significant loadings were discarded from the model. CFA results indicated that the model did not fit the data ( $\chi^2(517, N = 374) = 1644.595$ ,  $\chi^2/df = 3.18$ , CFI = .71, TLI = .68, GFI = .77, RMSEA = .08, SRMR = .10). The factor loadings ranged between .15 and .80 and their standard errors ranged between 0.07 and 2.00. Items' error variances on the same factor were correlated based on the suggested modification indices. Five sets of errors were correlated and included in the model (items 1 and 17, 21 and 32, 31 and 35, 6 and 18, 21 and 22). Following each correlation, an  $\chi^2$  difference test was performed (Tabachnick & Fidell, 2001).

Again, the final five-factor model did not fit the data well ( $\chi^2(512, N = 374) = 1409.674$ ,  $\chi^2/df = 2.75$ , CFI = .77, TLI = .74, GFI = .80, RMSEA = .07, SRMR = .09).

*Exploratory Factor Analysis*

Since CFA results indicated that the five-factor model did not provide a good fit to the data of this study, an EFA was used to determine the factor structure of the IPSM among Italian emerging adults. Principal Axis Factor (PAF) with varimax rotation was applied. The value of the Bartlett test of sphericity ( $\chi^2(630) = 4522.704$ ,  $p < .001$ ) indicated that data were acceptable for further analyses. The Kaiser-Meyer-Olkin value was high (KMO = .87), suggesting that the sample size was sufficient to provide stable factor solutions (Field, 2000). Communalities showed that only Item 9 has a value lower than .02 and, hence, it was removed. PAF analysis indicated that all the items showed factor loadings greater than .30, except Item 8 and Item 19. Furthermore, the scree-plot of eigenvalues indicated a three-factor solution. An examination of the rotated factor loadings has led to a drop in several items, resulting in a 27-item version of the IPSM. Item 9 was dropped because it showed a low communality value. Item 16 was dropped because it showed a factor loading lower than .30. Items 3, 15, 33, 26, 25, and 31 loaded on two or more factors with a difference of less than 0.20 and were also dropped. Finally, Item 18 was dropped because of similar loadings on two factors and a low and negative item-total correlation value (-.06). IPSM-It accounted for 41.52% of the total variance and showed a good Cronbach’s alpha coefficient ( $\alpha = .85$ ) (see Table 2).

**Table 2.** Three-Factor Solution: Rotated Factor Loadings ( $\lambda$ ), Communalities ( $h^2$ ), Item-Total Correlation ( $r_{it}$ ), Squared Multiple Correlation ( $R^2$ ) and Cronbach’s Alpha.

Item	$\lambda$			Total	$h^2$	$r_{it}$	$R^2$	$\alpha$ if item is deleted
	Factor 1	Factor 2	Factor 3					
30	.65				.54	.61	.54	.83
34	.64				.47	.51	.47	.84
10	.63	.31			.54	.66	.54	.83
23	.61				.43	.54	.43	.84
12	.58				.36	.47	.36	.84
17	.57				.52	.45	.52	.84
2	.55				.37	.42	.37	.84
36	.53				.33	.34	.33	.84
28	.48				.30	.43	.30	.84
35	.45				.38	.50	.38	.84
1	.45				.46	.35	.46	.84
19	.41				.27	.40	.27	.84
8	.38				.28	.28	.28	.85

Item	$\lambda$			Total	$h^2$	$r_{it}$	$R^2$	$\alpha$ if item is deleted
	Factor 1	Factor 2	Factor 3					
11	.35				.23	.25	.23	.85
5		.74			.58	.50	.58	.84
27		.67			.41	.34	.41	.84
24		.66			.51	.45	.51	.84
29		.59			.42	.49	.42	.84
4		.52			.30	.38	.30	.84
20*		-.50			.29	.18	.29	.85
13*		-.48			.34	.35	.34	.84
6*		-.34			.17	.06	.17	.85
7			.65		.40	.39	.40	.84
21			.61		.34	.02	.34	.86
32			.59		.30	.18	.30	.85
22			.58		.34	.35	.34	.84
14			.41		.25	.34	.25	.84
<b>% Variance</b>	22.46	11.08	7.98	41.52				
<b>Cronbach's alpha</b>	.85	.80	.71	.85				

\*reverse items

Every one of the 27 items loaded on one single factor ( $> .30$ ) with the only exception being represented by Item 10, which loaded onto two factors with a difference greater than  $.20$ . Communality values were  $\geq .20$  for each item, with a single exception of Item 6 (.17). Corrected item-total correlations were greater than  $.30$ , except for the items 20, 6, and 21. Squared multiple correlations were greater than  $.10$  for each item.

The first factor accounted for 22.46% of the variance and consisted of 14 items. In the original version of the IPSM, among these items, six were included in the Interpersonal Awareness subscale, three in the Need for Approval subscale, four in the Separation Anxiety subscale, and only one in the Fragile Inner Self subscale. Following Harb et al. (2002) and Dogan and Sapmaz (2012), we chose to label the first factor as *Interpersonal Worry and Dependency* (IWD).

The second factor accounted for 11.08% of the variance and included 8 items. Among these items three were originally included in the Fragile Inner Self subscale, three were in the Need for Approval subscale, one was in the Separation Anxiety subscale, and one was in the Interpersonal Awareness subscale. Furthermore, the three items from the Need for Approval subscale showed a negative loading on the second factor. For this reason, the scoring of items 6, 13, and 20 was reversed in subsequent analyses. Following Harb et al. (2002) and Dogan and Sapmaz (2012), we labeled the second factor as *Low Self Esteem* (LSE).

The third factor accounted for 7.98% of the total variance and consisted of 5 items, all of which were originally included in Boyce and Parker's (1989) Timidity

subscale. We labelled the third factor as *Unassertive Interpersonal Behavior* (UIB; Harb et al., 2002; Dogan & Sapmaz, 2012).

### Criterion validity

Descriptive statistics and Pearson correlation coefficients between the IPSM-It scores and the study variables are presented in Table 3. IWD and LSE significantly correlated with all the variables. The only exception was the correlation between IWD and External Anger Control which did not reach statistical significance ( $p > .05$ ). Correlation coefficients ranged from weak to moderate. UIB was significantly correlated with External Anger Expression ( $r = -.37, p < .001$ ), External Anger Control ( $r = .42, p < .001$ ), and Internal Anger Control ( $r = .20, p < .001$ ). The total score of the IPSM-It was correlated with all the variables, except External Anger Expression and External Anger Control ( $ps > .05$ ).

**Table 3.** Descriptive Statistics and Pearson Correlation Coefficients Between the IPSM-It Scores and the Variables in the Study.

	IWD	LSE	UIB	<i>M</i>	<i>SD</i>	Cronbach's $\alpha$
Depression	.37***	.59***	.09	9.11	7.68	.86
Anxiety	.41***	.40***	.05	13.26	9.70	.89
AE-O	.13*	.20***	-.37***	15.26	3.52	.63
AE-I	.39***	.50***	.11*	19.13	4.78	.77
AC-O	-.09	-.13**	.42***	22.25	3.93	.76
AC-I	-.14**	-.24***	.20***	22.90	4.78	.87
Life Satisfaction	-.24***	-.51***	-.00	23.07	6.00	.86
<i>M</i>	39.23	16.04	12.36	-	-	-
<i>SD</i>	7.07	4.38	2.94	-	-	-

Note. IWD: IPSM Interpersonal Worry and Dependency subscale; LSE: IPSM Low Self-Esteem subscale; UIB: IPSM Unassertive Interpersonal Behavior subscale; AE-O: External Anger Expression; AE-I: Internal Anger Expression; AC-O: External Anger Control; AC-I: Internal Anger Control

Note. \* $p \leq .05$ , \*\* $p \leq .01$ , \*\*\* $p \leq .001$

### Reliability Analysis

Cronbach's alpha coefficients for the total score, IWD, and LSE were high (respectively  $\alpha = .88, .85$ , and  $.80$ ). UIB showed an acceptable Cronbach's alpha value ( $\alpha = .71$ ). Inter-correlations among the factors showed that IWD was significantly correlated with LSE ( $r = .32$ ) and UIB ( $r = .25$ ). The correlation between LSE and UIB was not statistically significant.

## Discussion

The purpose of this study was to examine the psychometric properties of the IPSM in a non-clinical sample of Italian emerging adults. Investigation of the psychometric properties of IPSM-It can help to further facilitating research on IPS, expanding its cross-cultural use, allowing cross-cultural comparisons, and assisting clinical practice. Moreover, previous research has raised important questions about the factorial structure of the IPSM that deserve further research.

Results of a CFA with a five-factor structure of the IPSM-It revealed that this model did not fit the data sufficiently in the sample of Italian emerging adults. Thus, our results did not support the original five-factor structure (Boyce & Parker, 1989) of the scale. Rather, our results support a three-factor structure, in line with findings on the Persian (Harb et al. (2002) and Turkish versions (Dogan and Sapmaz, 2012) of the IPSM. Differences across sociocultural contexts include differences in interpersonal relations (Albert & Trommsdorff, 2014), which might reflect differences in the variability and interdependencies among the items. Considering that the item composition of our dimensions was very similar to those found by Harb et al. (2002) and Dogan and Sapmaz, (2012), we preferred to use the same labels, which are *Interpersonal Worry and Dependency* (IWD), *Low self-esteem* (LSE), and *Unassertive Interpersonal Behavior* (UIB).

Individuals with high levels of IWD may give great importance to others' judgments and opinions about themselves since their value appears to be externally defined. This dependency on interpersonal evaluation also implies the need of keeping significant others close. These aspects are well represented by the Italian version of items such as "*I care about what people feel about me*" and "*I worry about losing someone close to me*". Items of LSE reflect low self-esteem and self-image, feeling unliked by others, and anticipating criticisms from others. This factor is well represented by the item "*If others knew the real me, they would not like me*". Items of UIB reflect the tendency to give up on personal needs and preferences to avoid upsetting others or stepping on their toes. The item "*I will do something I don't want to do rather than offend or upset someone*" well exemplifies such unassertive interpersonal style. It should be noted that Item 21 ("*I find it hard to get angry with people*") showed the lowest item-total correlation value and, if deleted, the total Cronbach's alpha would slightly increase. Even though this item may be problematic, we decided to include it in the IPSM-It. In particular, Item 21 may measure an internal experience of anger, regardless of an individual's inclination to manifest it assertively. Individuals may respond to this item regardless of their level of UIB. Specifically, individuals with high levels of UIB may rate low on this item by not finding it hard to get angry with others per se, but they may avoid manifesting external anger. Thus, we suggest rephrasing Item 21 to "*Even if people make me*

*angry, I find it hard to express it to them*\* “ to make the item more coherent with the measured construct. Nevertheless, future studies with different sample groups are needed to further explore the factorial structure of the IPSM-It.

The reliability of the IPSM-It is satisfactory. Specifically, the internal consistency was high for the IWD and LSE subscales. Internal consistency for the UIB was lower, probably because this subscale has a small number of items ( $n = 5$ ), but still acceptable and consistent with previous studies reporting on a three-factor structure (Harb et al., 2002; Dogan & Sapmaz, 2012).

The results from this study support the criterion validity of the IPSM-It. In line with previous studies, IWD and LSE dimensions showed positive correlations with both depression and anxiety (Boyce et al., 1992; Dogan & Sapmaz, 2012; Masillo et al., 2014; Mohammadian et al., 2017, 2018; You et al., 2020), indicating that individuals with higher levels of worry about interpersonal relations, fear of others' opinions and responses, low self-esteem, and fear of criticism are more likely to report on depression and anxiety symptoms.

The results from this study also showed that the UIB dimension does not correlate either with depression or anxiety. These results seem to be in contrast with previous research suggesting that IPS constitutes an important factor for the development and maintenance of depression (Boyce et al., 1992), and low assertiveness is an indicator of depression (Weissman & Paykel, 1974). However, they are in line with findings reported by Dogan and Sapmaz (2012) and suggest that there may be differential associations of the IPSM dimensions with diverse depressive symptoms. While ISD and LSE dimensions seem to be more important for depression, unassertive behavior seems to play a less important role.

Similarly, the timidity subscale of the IPSM is related to agoraphobia and simple phobia, whereas the subscale of separation anxiety is associated with agoraphobia, panic disorder, and generalized anxiety disorder (Wilhelm et al., 2004), which indicates that IPSM subscales might have differential associations across anxiety disorders (Harb et al., 2002). Taken together, these findings suggest that the role of the multidimensional IPS construct in increasing depression and anxiety symptoms needs further attention.

The IPSM-It also proved concurrent validity with measures of anger expression and control. Findings suggest that individuals with higher interpersonal sensitivity might be more inclined to feel or control anger, as they frequently feel threatened by other's evaluations, and those threats appear even more reinforcing because of their low self-esteem. Anger may also be activated by the perception of negative evaluation and low self-esteem (Dadds et al., 1993). Yet, it may enhance the real or perceived risk of more criticism, negative evaluations, and negative feedback.

---

\* In Italian version “Anche se gli altri mi fanno arrabbiare, trovo difficile arrabbiarmi con le persone”.

Furthermore, in line with Harb et al. (2002), the IWD and LSE subscales were negatively related to life satisfaction. More precisely, a less positive attitude towards oneself, weaker self-worth, and giving great importance to others' opinions are associated with lower levels of life satisfaction. Furthermore, there was no correlation between life satisfaction and the UIB subscale. Considering assertiveness as a facet of personality, previous studies highlighted gender differences in the relation between assertiveness and life satisfaction. Specifically, life satisfaction was related to positive emotionality in females, whereas assertiveness was a significant predictor of life satisfaction in males (Herringer, 1998; Schimmack et al., 2004). Further studies are needed to explore the role of gender in the relationship between IPSM-It dimensions, especially unassertiveness, and life satisfaction.

This study has some limitations. First, the utilization of only self-report questionnaires has some disadvantages such as social desirability, lack of self-awareness, and common method variance biases. Future research should include different types of measurements like behavioral observations of interpersonal behaviors in the context of social rejection. Second, the sample in this study reflected a convenience sampling method and exclusively consisted of emerging adults, who were mostly female and undergraduate students. Therefore, the generalizability of the results is limited. The psychometric properties of IPSM-It should be further examined in more heterogeneous non-clinical samples. Third, other psychometric properties of the IPSM-it deserve attention in future research, such as the test-retest reliability, the invariance of the factorial structure across clinical and non-clinical samples, and the treatment sensibility. Further, the moderating role of variables such as the relationship status to explain the relation of IPS with negative psychosocial outcomes warrants future research. In this regard, and even though literature is scarce, several studies suggest that IPS may moderate the relationship between romantic stress and depression (Rizzo et al., 2006), on one hand, and between spousal conflict and negative affect, on the other hand (Smith and Zautra, 2001).

In conclusion, the IPSM-It showed good psychometric properties and proved to be a useful tool for the investigation of IPS. Nevertheless, our findings did not support the five-factor structure proposed by Boyce and Parker (1989) for the IPSM, but the three-factor solution found by other authors (Dogan and Sapmaz, 2012; Harb et al., 2002). Our findings also proved the internal consistency and criterion validity of the IPSM-It.

## **Authors' Notes**

**Conflict of Interest.** On behalf of all authors, I hereby declare that there are no potential conflicts of interest associated with this publication.

**Funding.** The authors did not receive support from any organization for the submitted work.

**Publication Ethics.** This study was performed in line with the principles of the 1964 Declaration of Helsinki and its later amendments (2001). Approval was granted by the Institutional Review Board of the Pisa University. The 2016 American Psychological Association Ethical Principles of Psychologists and Code of Conduct (APA, 2017) was also applied. Informed consent was obtained from all individual participants included in the study.

**Authorship.** LC has contributed to the writing of the introduction and contributed to data collection. CA-A has contributed to the data analysis and the drafting of method and results sections of the manuscript. GT has contributed to the data collection. OB and FR and MS have selected the sample and supervised data collection. Moreover, they contributed in interpretation of results. CB has supervised the design and drafting the discussion section of the manuscript. All authors revised the final version of manuscript.

## References

- Albert, I., & Trommsdorf, G. (2014). The role of culture in social development over the life span: An interpersonal relations approach. *Online Readings in Psychology and Culture*, 6(2). <http://dx.doi.org/10.9707/2307-0919.1057>
- Beck, A. T., Epstein, N., Brown, G. & Steer, R. A. (1988b). An inventory for measuring clinical anxiety: psychometric properties. *Journal of Consulting and Clinical Psychology* 56(6), 893 –897. <https://doi.org/10.1037/0022-006X.56.6.893>
- Beck, A. T., Steer, R. A. & Garbin, M. G. (1988a). Psychometric properties of the Beck Depression Inventory: Twenty-five years of evaluation. *Clinical Psychology Review*, 8(1), 77–100. [https://doi.org/10.1016/0272-7358\(88\)90050-5](https://doi.org/10.1016/0272-7358(88)90050-5)
- Beck, A. T., Ward, C. H., Mendelson, M., Mock, J., & Erbaugh, J. (1961). An inventory for measuring depression. *Archives of General Psychiatry*, 4(6), 561–571. <https://doi.org/10.1001/archpsyc.1961.01710120031004>
- Bowlby, J. (1977). The making and breaking of affectional bonds: I. Aetiology and psychopathology in the light of attachment theory. *British Journal of Psychiatry*, 130, 201-210. <https://doi.org/10.1192/bjp.130.3.201>
- Boyce, P., & Parker, G. (1989). Development of a scale to measure interpersonal sensitivity. *Australian and New Zealand Journal of Psychiatry*, 23(3), 341–351. <https://doi.org/10.1177/000486748902300301>
- Boyce, P., Hickie, I., Parker, G., Mitchell, P., Wilhelm, K., & Brodaty, H. (1992). Interpersonal sensitivity and the one-year outcome of a depressive episode.

- Australian and New Zealand Journal of Psychiatry*, 26(2), 156–161. <https://doi.org/10.3109/00048679209072022>
- Byrne, B. M. (2016). *Structural equation modelling with AMOS. Basic concepts, applications, and programming* (3<sup>rd</sup> ed.). New York: Routledge.
- Comunian, L. (2004). *Manuale STAXI-2 state-trait anger expression inventory-2. adattamento italiano. Florence: Organizzazioni speciali.*
- Dadds, M. R., Gaffney, L. R., Kenardy, J., Oei, T. P., & Evans, L. (1993). An exploration of the relationship between expression of hostility and the anxiety disorders. *Journal of Psychiatry Research*, 27, 17–26. [https://doi.org/10.1016/0022-3956\(93\)90046-5](https://doi.org/10.1016/0022-3956(93)90046-5)
- Di Fabio, A., & Busoni, L. (2009). Proprietà psicometriche della versione italiana della Satisfaction with Life Scale (SWLS) con studenti universitari. *Counseling: Giornale Italiano di Ricerca e Applicazioni*, 2(2), 201–211.
- Diener, E. D., Emmons, R. A., Larsen, R. J., & Griffin, S. (1985). The satisfaction with life scale. *Journal of Personality Assessment*, 49(1), 71–75. [https://doi.org/10.1207/s15327752jpa4901\\_13](https://doi.org/10.1207/s15327752jpa4901_13)
- Dogan, T., & Sapmaz, S. (2012). Psychometric analysis of the interpersonal sensitivity measure (IPSM) among Turkish undergraduate students. *Journal of Theoretical Educational Science*, 5(2), 143–155.
- Field, A. (2000). *Discovering statistics using SPSS for Windows*. London: Sage
- Harb, G. C., Heimberg, R. G., Fresco, D. M., Schneier, F. R., & Liebowitz, M. R. (2002). The psychometric properties of the Interpersonal Sensitivity Measure in social anxiety disorder. *Behaviour Research and Therapy*, 40(8), 961–979. [https://doi.org/10.1016/S0005-7967\(01\)00125-5](https://doi.org/10.1016/S0005-7967(01)00125-5)
- Herringer, L. G. (1998). Facets of extraversion related to life satisfaction. *Personality and Individual Differences*, 24(5), 731–733. [https://doi.org/10.1016/S0191-8869\(97\)00194-3](https://doi.org/10.1016/S0191-8869(97)00194-3)
- Lee, K. U., Jung, N. Y., Rauch, S. A., Chae, J. H., Lee, H. K., Kweon, Y. S., & Lee, C. T. (2013). Psychometric properties of the Korean version of the Interpersonal Sensitivity Measure (IPSM-K). *Comprehensive Psychiatry*, 54(7), 918–924. <https://doi.org/10.1016/j.comppsy.2013.03.022>
- Masillo, A., Valmaggia, L. R., Lanna, A., Brandizzi, M., Lindau, J. F., Curto, M., Solfanelli, A., Patanè, M., Godeas, L., Leccisi, D., Girardi, P., & Fiori Nastro, P. (2014). Validation of the Italian version of interpersonal sensitivity measure (IPSM) in adolescents and young adults. *Journal of Affective Disorders*, 156, 164–170. <https://doi.org/10.1016/j.jad.2013.12.012>
- Mohammadian, Y., Mahaki, B., Lavasani, F. F., Dehghani, M., & Vahid, M. A. (2017). The psychometric properties of the Persian version of interpersonal sensitivity measure. *Journal of Research in Medical Sciences: The Official Journal of Isfahan University of Medical Sciences*, 22, 1–7. <https://doi.org/10.4103/1735-1995.199093>

- Moksnes, U. K., & Espnes, G. A. (2013). Self-esteem and life satisfaction in adolescents - gender and age as potential moderators. *Quality of Life Research*, 22, 2921–2928. <https://doi.org/10.1007/s11136-013-0427-4>
- Rizzo, C.J., Daley, S.E., & Gunderson, B.H. (2006). Interpersonal sensitivity, romantic stress, and the prediction of depression: A study of inner-city, minority adolescent girls. *Journal of Youth and Adolescence*, 35(3), 469–478. <https://doi.org/10.1007/s10964-006-9047-4>
- Schimmack, U., Oishi, S., Furr, R. M., & Funder, D. C. (2004). Personality and life satisfaction: A facet-level analysis. *Personality and Social Psychology Bulletin*, 30(8), 1062–1075.
- Scilligo, P. (1983). Caratteristiche psicometriche del Questionario di Depressione di Beck. *Psicologia Clinica*, 3, 397–408.
- Sica, C. & Ghisi, M. (2007). The Italian versions of the Beck Anxiety Inventory and the Beck Depression Inventory-II: Psychometric properties and discriminant power. In Lange, M. A. ed. *Leading-edge psychological tests and testing research*. Hauppauge, NY: Nova Science Publishers. 27–50.
- Smith, B.W. & Zautra, A.J. (2001). Interpersonal sensitivity and reactivity to spousal conflict in healthy older women. *Personality and Individual Differences*, 31, 915–923. [https://doi.org/10.1016/S0191-8869\(00\)00193-8](https://doi.org/10.1016/S0191-8869(00)00193-8)
- Spielberger, C. D. (2010). State-Trait anger expression inventory. *The Corsini Encyclopedia of Psychology*, 1, 1. <https://doi.org/10.1002/9780470479216.corpsy0942>
- Swee, M. B., Kaplan, S. C., & Heimberg, R. G. (2018). Assertive behavior and assertion training as important foci in a clinical context: The case of social anxiety disorder. *Clinical Psychology: Science and Practice*, 25(1), e12222. <https://doi.org/10.1111/cpsp.12222>
- Tabachnick, B. G., & Fidell, L. S. (2007). *Using multivariate statistics* (5th ed.). Allyn and Bacon.
- Weissman, M.M., & Paykel, E.S. (1974). *The depressed women: A study of social relationships*. Oxford: U Chicago Press
- Wilhelm, K., Boyce, P., & Brownhill, S. (2004). The relationship between interpersonal sensitivity, anxiety disorders and major depression. *Journal of Affective Disorders*, 79(1–3), 33–41. [https://doi.org/10.1016/S0165-0327\(02\)00069-1](https://doi.org/10.1016/S0165-0327(02)00069-1)
- You, Z., Liu, Y., Tan, Q., Xu, Y., Zhang, L., & Andrasik, F. (2020). Development and validation of the Chinese version of Short-Form of Interpersonal Sensitivity Measure (IPSM). *Community Mental Health Journal*, 57, 277–284. <https://doi.org/10.1007/s10597-020-00646-z>



---

## THE EFFECTIVENESS OF COMPASSIONATE MIND TRAINING (CMT) FOR UNDERGRADUATE STUDENTS

---

*Tünde Póka<sup>1\*</sup> and Andrea Barta<sup>2</sup>*

<sup>1</sup> Evidence-Based Psychological Assessment and Interventions Doctoral School, Babeş-Bolyai University; Department of Applied Psychology, Babeş-Bolyai University Cluj-Napoca, Romania. ORCID ID <https://orcid.org/0000-0003-1919-2375>; e-mail: [tunde.poka@ubbcluj.ro](mailto:tunde.poka@ubbcluj.ro)

<sup>2</sup> Evidence-Based Psychological Assessment and Interventions Doctoral School, Babeş-Bolyai University; Department of Applied Psychology, Babeş-Bolyai University Cluj-Napoca, Romania. ORCID ID <https://orcid.org/0000-0001-8754-6097>; e-mail: [andrea.barta@ubbcluj.ro](mailto:andrea.barta@ubbcluj.ro)

---

### Abstract

The study aimed to investigate the feasibility and effectiveness of face-to-face, group-based Compassionate Mind Training (CMT) for undergraduate students.

Following a 12-week CMT intervention, a cohort of undergraduate students in the CMT group ( $n = 45$ ) and their counterparts in the passive control group ( $n = 21$ ) were asked to fill out assessments before, during, immediately after, and three months following the completion of the intervention. These measures encompassed a range of factors, including self-compassion, negative affect, various forms of positive affect, depression, anxiety, stress, life satisfaction, and dysfunctional attitudes.

Compared with the control group, participants belonging to the CMT group showed significant increases in self-compassion and self-warmth, along with decreases in negative affect, self-coldness, dysfunctional attitudes, depression, and stress. However, mediation analyses, when applied within longitudinal models, did not establish the significance of self-compassion, self-coldness, or self-warmth as mediators in the context of the CMT's impact on negative affect and soothing positive affect.

The results support the effectiveness of a 12-week, group-based, face-to-face CMT for undergraduate students. Yet, they also cast doubt on self-compassion as the primary mechanism driving these changes, given the absence of supporting longitudinal evidence.

**Keywords:** self-compassion, intervention, students, CMT, affect.

---

\* Correspondence concerning this article should be addressed to Tünde Póka, Babeş-Bolyai University, Faculty of Psychology and Educational Sciences, Department of Applied Psychology, No. 128 December 21, 1989 Boulevard, 400603, Cluj-Napoca, Romania.  
E-mail: [tunde.poka@ubbcluj.ro](mailto:tunde.poka@ubbcluj.ro)

Undergraduate students report reduced well-being and increased psychological distress compared to the general community (Bore et al., 2016; Larcombe et al., 2016; Regehr et al., 2013), therefore it is essential to design effective interventions in order to reduce their distress and improve their well-being. Several factors can constitute sources of distress: academic performance, pressure to succeed, post-graduation plans, financial worries, quality of sleep, relationship with friends, relationship with family, general health issues, body image, and self-esteem (Beiter et al., 2015). Given that they are particularly vulnerable to perfectionism-related distress (Arpin-Cribbie et al., 2012) and self-criticism is a transdiagnostic factor in psychopathology (McIntyre et al., 2018), it is also crucial to develop interventions that can effectively manage their self-criticism. One promising way to reach these goals is through the cultivation of self-compassion (Dundas et al., 2017; Mantelou & Karakasidou, 2017). Self-compassion can be described as a healthy attitude towards one's pain and suffering, which is an integral part of human life. It implies a gentle, understanding, and supportive approach towards oneself, instead of employing harsh self-criticism (Germer, 2009; Neff, 2003a). Furthermore, self-compassion is a provably acquirable skill with numerous advantages (Ferrari et al., 2019, Póka et al., 2023).

In addition to longer and more complex self-compassion programs, such as the Mindful-Self Compassion (MSC) program (Neff & Germer, 2012) and Compassionate Mind Training (CMT; Irons & Heriot-Maitland, 2021), researchers are also investigating the effectiveness of simpler, shorter interventions for improving distress and well-being levels. For example, writing self-compassionate letters (an exercise most commonly used in studies to elicit and increase self-compassion) can reduce negative emotional states (Leary et al., 2007) and depression, as well as increase happiness levels in the general population (Shapira & Mongrain, 2010).

Promising results emerge from meta-analyses investigating interventions aimed at enhancing self-compassion (Ferrari et al., 2019) and general well-being (Zessin et al., 2015). They also demonstrate effectiveness in fostering positive affect, mindfulness, life satisfaction, eating behaviors, and body image; furthermore, these interventions show efficacy in mitigating negative affect, eating pathology, depression, stress, anxiety, self-criticism, and rumination (Ferrari et al., 2019; Póka et al., 2023; Turk & Waller, 2020; Wakelin et al., 2022). Notably, the acquisition of self-compassion is particularly attainable within group settings and through in-person intervention methods (Ferrari et al., 2019; Póka et al., 2023). However, it appears that self-compassion interventions commonly utilized among college students, such as self-compassion writing exercises, exhibit reduced benefits compared to their general effectiveness (Ferrari et al., 2019; Póka et al., 2023). It is therefore important to develop and adapt interventions tailored towards them, potentially yielding greater success in fostering self-compassion, enhancing well-being, and alleviating distress. A promising avenue in this pursuit is Compassionate

Mind Training (CMT; Irons & Heriot-Maitland, 2021), a group intervention conducted in person and rooted in the principles and application of Compassion-Focused Therapy (Gilbert 2009a, 2009b, 2014), which appears to hold considerable promise for achieving these objectives.

### *The Compassionate Mind Training*

The Compassionate Mind Training (CMT; Irons & Heriot-Maitland, 2021) is a group-based, 8-session program, split into 2.5-hour sessions every week. The program integrates a solid theoretical foundation encompassing written, imaginative, meditative, and body-based exercises (Gilbert 2009a, 2009b, 2014). Throughout the training, participants acquire knowledge about the development and operation of the mind, what functions it serves, and what factors influence it. This accumulation of insights contributes to a reduction in feelings of shame and blame. Participants realize that we all have a brain, a mind, that although it has many benefits, it is also likely to create problems for us, but it wasn't our choice to be built that way. Furthermore, we did not choose the context in which we were born, although these aspects have a huge influence on how we function today. The key message conveyed through this methodology emphasizes that one is not at fault, but at the same time, one bears a sense of responsibility. Participants are introduced to the definition of compassion as a motive (compassion being defined as the sensitivity to suffering, as well as the attempt and commitment to alleviate or prevent it), the three flows of compassion (self-compassion, compassion for others, and compassion from others), the two psychologies of compassion (engagement and action), the competencies required for compassion, the three main qualities of compassion (strength, wisdom, engagement), the three basic emotion regulation systems (threat, drive, and soothing system), and the function of compassion in regulating these systems (Gilbert, 2009a, 2009b, 2014). Through the program, participants engage in a range of activities aimed at cultivating a compassionate mindset. These activities include imaginative exercises like the compassionate place and compassionate image, body-centered exercises like compassionate breathing and compassionate touch, and written exercises such as composing compassionate letters and exploring the concept of “multiple selves,” among others. Moreover, participants can openly discuss their experiences within small group settings, as well as with the larger group as a whole.

The results of the preliminary investigations show that CMT is a feasible and effective intervention for the general population. It has the potential to improve all three flows of compassion while nurturing positive emotions and a sense of well-being (including physiological well-being measured by heart rate variability) (Irons & Heriot-Maitland, 2021; Matos et al., 2017). Furthermore, it has been shown to reduce self-criticism, shame, fears of compassion, and distress (Irons & Heriot-Maitland, 2021; Matos et al., 2017). Findings have highlighted the importance of improving one's self-compassion for overall increases in well-being and decreases

in psychological distress (Irons & Heriot-Maitland, 2021). The results of Matos and colleagues' (2022) study further confirmed that self-compassion was the main mechanism of change in a two-week CMT intervention. Self-compassion acted as a mediator for the intervention's impact on various factors, including self-criticism, depression, stress, and shame, as well as positive emotional states like safe and relaxed feelings. These interventions are particularly recommended for individuals grappling with elevated levels of shame and self-criticism, who find it challenging to engage in self-soothing and self-acceptance (Gilbert, 2009a, 2009b, 2014; Gilbert & Procter, 2006). Given that college students are exceptionally vulnerable to perfectionism-related distress (Arpin-Cribbie et al., 2012), and self-criticism is a transdiagnostic factor that can predict symptoms of psychopathology among them (especially depression) (McIntyre et al., 2018), this group-based intervention may be optimal for this population in reducing their distress levels.

Beaumont and Martin (2016) emphasized the importance of developing self-compassion and compassion for others in therapy students using Compassionate Mind Training. Given the high rates of burnout and high levels of psychological distress experienced by psychological therapists (especially younger and newer therapists), self-compassion can be an important personal resource for them, increasing their well-being and reducing distress (Boellinghaus et al., 2013; Finlay, Jones et al., 2017; Yela et al., 2020), as well as the levels of burnout among them (Eriksson et al., 2018; Gerber & Anaki, 2021). Beaumont et al. (2021) adopted a mixed-methods approach, employing both qualitative and quantitative techniques to investigate the effectiveness of a 12-week CMT intervention for students pursuing careers in helping professions. Their findings also demonstrated promising outcomes regarding the viability and effectiveness of the intervention within an academic setting. However, it's worth noting that this study primarily focused on self-compassion and self-criticism and did not encompass clinical outcomes (such as negative affect, depression, anxiety, stress, etc.) or markers of well-being (like positive affect, life satisfaction, etc.). The results of the qualitative data suggested that personal practice and self-reflection are important aspects of cultivating a compassionate mindset and increasing levels of self-compassion (Beaumont et al., 2021).

### *Objectives*

The main objective of the current study was to investigate the effectiveness of Compassion Mind Training for improving undergraduate students' well-being and reducing their distress. The primary outcomes examined encompass the influence on negative affect and soothing positive affect. Secondary outcomes include several other distress indicators (i.e., depression, anxiety, and stress), as well as indicators of well-being (i.e., activating positive affect and life satisfaction). We also aimed to explore the pathways leading to the impact of the intervention using mediation

analyses. Given that cross-sectional analyses may indicate the existence of a significant indirect effect, even if the true longitudinal indirect effect is shown to be zero (Goldsmith et al., 2018; Maxwell et al., 2011), the present study sought to explore the longitudinal mediation roles of self-compassion and dysfunctional attitudes concerning the clinical benefits resulting from the intervention, particularly focusing on the primary outcomes: the aforementioned negative and soothing positive affect, respectively.

Based on the importance of distinguishing between self-warmth (positive dimensions of self-compassion, compassionate behaviors) and self-coldness (negative dimensions of self-compassion, uncompassionate behaviors) (Chio et al., 2021; Muris and Petrocchi, 2016), we also aim to investigate the individual longitudinal mediation roles of self-warmth and self-coldness.

### *Hypotheses*

Based on the literature, it was expected that the implementation of Compassionate Mind Training would effectively reduce students' negative affect and improve their soothing positive affect. Following the intervention, it was anticipated that students belonging to the intervention group would report lower levels of negative affect and higher levels of soothing positive affect compared to those in the control group. Additionally, our hypotheses proposed that this training regimen would lead to enhancements in self-compassion, self-warmth, and other indicators of well-being, such as activated positive affect and life satisfaction. Concurrently, we hypothesized that it would also result in a reduction in self-coldness, dysfunctional attitudes, and other signs of distress, including depression, anxiety, and stress.

Finally, we predicted that the effects of the intervention on negative affect and soothing positive affect would be mediated by self-compassion. This implies that participation in Compassionate Mind Training would lead to the observed reduction in negative affect and an increase in soothing positive affect through the growth of self-compassion, particularly by addressing self-coldness.

## **Method**

### *Participants*

We conducted an a priori power analysis using G\*Power 3 (Faul et al., 2007) to determine the required sample size. For a mixed ANOVA involving two groups and four measurements, with a significance level of 0.05 and a desired statistical power of 0.80, the analysis indicated that a sample size of  $n = 24$  would be needed to detect a medium effect size ( $f = 0.25$ ). In the case of an independent t-test, also

with a significance level of 0.05 and a desired statistical power of 0.80, the analysis showed that a sample size of  $n = 128$  would be required to detect a medium effect size ( $d = 0.5$ ). The intervention group consisted of second- year undergraduate students majoring in Psychology, while the control group comprised second-year undergraduate students from other majors. The allocation was non-random (i.e., the Psychology students sought students to be part of the control group, matched in terms of age and declared gender). The participant recruitment and flow are depicted in Figure 1.

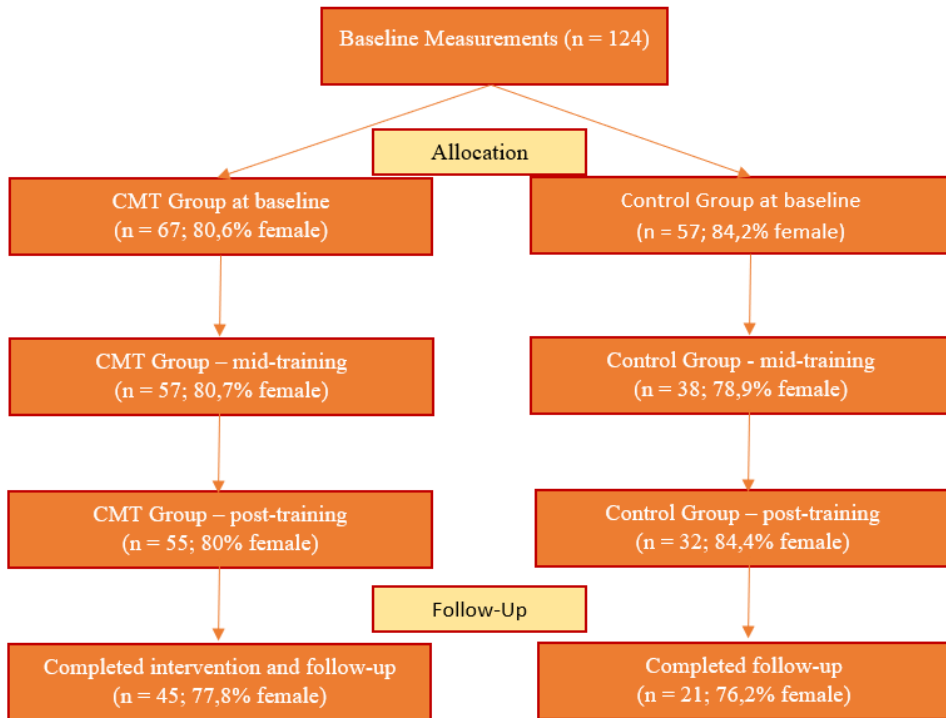

Figure 1. Participants' Flow

Initial measurements were carried out by 124 students, with 67 being from the CMT group and majoring in psychology, while 57 belonged to the control group and pursued other majors. A substantial proportion of the participants were identified as female, accounting for more than 80% of the total. Notably, the overall dropout rate was 46.77%, with a comparatively lower dropout rate observed in the CMT group at 32.83%, as opposed to the control group's rate of 63.15%.

### *Instruments*

#### *Self-Compassion, Self-Warmth, and Self-Coldness*

Self-compassion, self-warmth, and self-coldness were assessed using the Self-Compassion Scale – Short Form (SCS-SF; Raes et al., 2011), a 12-item version of the original Self-Compassion Scale (SCS; Neff, 2003b). The SCS-SF appraises each facet of self-compassion (i.e., self-kindness, self-judgment, common humanity, isolation, mindfulness, over-identification) through two items for each component (e.g., “I try to see my failings as part of the human condition”). Participants responded on a five-point Likert scale. To calculate self-compassion results, the average of the six items measuring self-compassionate behaviors (self-kindness, common humanity, mindfulness) was computed, while scores for uncompassionate behaviors towards oneself (self-judgment, isolation, over-identification) were reverse-coded and averaged. Similarly, self-warmth (self-compassionate behaviors) and self-coldness (uncompassionate behaviors) scores were determined by averaging the respective subscale items (items measuring uncompassionate behaviors were not reverse-coded to calculate self-coldness). Elevated scores on self-compassion, self-warmth, and self-coldness indicated higher levels of those qualities. The scale exhibited acceptable internal consistency for the global self-compassion indicator ( $\alpha = .76$ ) and self-coldness ( $\alpha = .75$ ), while the internal consistency of the self-warmth subscale was considered questionable ( $\alpha = .64$ ).

#### *Depression, Anxiety, and Stress*

Levels of depression, anxiety, and stress were assessed using the 21-item version of the Depression Anxiety Stress Scale (DASS-21; Lovibond & Lovibond, 1995). Participants provided ratings on a scale ranging from 0 (*does not apply to me at all*) to 3 (*applies to me very much, or most of the time*) to indicate the frequency of their typical experience of each symptom. Subsequently, scores for the variables were obtained by summing up the seven items pertaining to stress, depression, and anxiety, respectively. The total score for each subscale was then doubled. Higher scores indicate higher levels of depression, anxiety, and stress. In the current study, the DASS-21 demonstrated good internal consistency for depression ( $\alpha = .87$ ), along with acceptable consistency for both anxiety ( $\alpha = .77$ ) and stress ( $\alpha = .77$ ).

#### *Negative Affect*

To measure the subjective dimension of distress (i.e., negative affect), we used the abbreviated Hungarian version of the Emotional Distress Profile (Profilul Distresului Emoțional - PDE; Opriș & Macavei, 2005). The scale was originally developed and validated in Romania and presents good psychometric properties and excellent internal consistency ( $\alpha = 0.94$ ) as a complex indicator of emotional distress.

The original scale consists of 26 adjectives describing negative affect, such as “sad” and “depressed”. The present study utilises 12 items that had adequate face validity according to the translation. Participants were asked to rate on a five-point Likert scale the extent to which the given affective items were typical of their experiences in the past two weeks. The scale exhibited very good internal consistency ( $\alpha = 0.89$ ) in measuring negative affect in the present sample.

#### *Soothing and Activating Positive Affect*

The various types of positive affect (i.e., soothing and activating positive affect) were assessed using the Types of Positive Affect Scale (Gilbert et al., 2008), which consists of 18 items appraising three distinct types of positive affect (soothing, relaxing, and activating positive affect). Participants rated their alignment with each statement on a scale ranging from 1 (*Not characteristic of me*) to 5 (*Very characteristic of me*). The scale measures the extent to which participants experience these feelings frequently. The variable scores were calculated by summing the dedicated items. In this study, the focus was on measuring soothing and activating positive affect. The subscale assessing soothing positive affect exhibited questionable internal consistency ( $\alpha = .60$ ), while the subscale evaluating activating positive affect demonstrated acceptable internal consistency ( $\alpha = .75$ ). The results mirror those of the original English instrument, where the activating positive affect subscale displayed higher internal consistency ( $\alpha = 0.83$ ) compared to the subscale measuring feelings of safeness/contentment positive affect ( $\alpha = 0.73$ ).

#### *Dysfunctional Attitudes*

The Dysfunctional Attitude Scale (DAS; Weissman & Beck, 1978) is a self-report instrument designed to measure the presence and intensity of dysfunctional attitudes. The Hungarian version of the DAS (Kopp, 1985) is composed of 35 items, with each of the seven categories of dysfunctional attitudes (need for approval, need for love, need for achievement, perfectionism, entitlement, omnipotence, and autonomy) encompassing five items. These are rated on a 5-point Likert scale ranging from -2 (*strongly disagree*) to 2 (*strongly agree*). As an illustration, an item assessing the need for approval is: “I need other people’s approval in order to be happy”. For the purposes of this study, an aggregate measure of dysfunctional attitudes was computed by summing the individual item scores. The scale exhibited good internal consistency in capturing dysfunctional attitudes ( $\alpha = .83$ ).

#### *Life Satisfaction*

The five-item Hungarian version of the Satisfaction with Life Scale (SWLS; Diener et al., 1985; Martos et al., 2014) was chosen as the tool to gauge participants’ alignment with statements concerning their overall perceived well-being. These statements include phrases such as “In most ways, my life is close to ideal”, and participants rate their agreement on a scale from 1 (*strongly disagree*) to 7 (*strongly*

*agree*). The variable scores were derived by summing the item ratings. The SWLS has shown high internal consistency, test-retest reliability, and validity (Diener et al., 1985). Additionally, good internal consistency was also confirmed in the current study ( $\alpha = .80$ ).

### *Procedure and Design*

The study was undertaken following the Code of Ethics of the American Psychological Association and was approved by the local Ethics Committee. Employing an interventional design, this study followed a parallel non-randomized allocation involving multiple assessments, specifically a 2 (group: intervention, passive control) by 4 (time: T1: baseline, T2: mid-test, T3: post-test, T4: 3-month follow-up) matrix. The data collection process was conducted online using Google Forms at each of the four time points (T1: early October 2022, T2: mid-November 2022, T3: mid-January 2023, and T4: mid-April 2023).

The primary focus of measurement encompassed negative affect and soothing positive affect. However, additional factors were also assessed, including various indicators of distress (such as depression, anxiety, and stress) and well-being (such as activating positive affect and life satisfaction). Furthermore, the study also evaluated potential underlying mechanisms, including self-compassion, self-coldness, self-warmth, and dysfunctional attitudes.

The intervention group consisted of second-grade undergraduate students majoring in Psychology, while the control group comprised second-grade undergraduate students from other majors matched in terms of age and declared gender. No group intervention was administered to the control group throughout the study period. This pragmatic trial was conducted to assess the feasibility and effectiveness of Compassionate Mind Training within an academic setting, reflecting real-world circumstances.

The Compassionate Mind Training (CMT) for students embodies a 12-session group program, each lasting about 2 hours, including a ten minutes break mid-session. This intervention was developed by drawing upon existing protocols and manuals for cultivating a compassionate mindset (Beaumont & Martin, 2016; Gilbert, 2009b; Irons & Beaumont, 2017; Irons & Heriot-Maitland, 2021). The training was delivered weekly in a face-to-face format in an academic context by an accredited CBT and CFT psychotherapist (the first author). A two-week break was incorporated during holidays, during which participants were encouraged to continue practicing. The sessions had the following structure: 1) Beginning (grounding exercise, reviewing the weekly practice); 2) Exploration of the designated session theme (psychoeducation, experiential activities, writing tasks, reflections in small- and large group settings); 3) Ending (session summary and reflections, outlining practices for the following week).

Participants exclusively shared personal information and experiences that related to the model, and only engaged in exercises they felt comfortable with.

During exercises, participants were guided to focus on mild to moderate concerns, avoiding overwhelming issues. A short outline of each session is provided in Table 1. Supplementary materials were available to aid weekly practices, including audio files, written handouts encompassing ideas discussed in each session, and worksheets to facilitate independent practice during the week. Encouragement was extended for daily practice, and at the start of each session, discussions centered on home practice, encountered challenges, and strategies for managing them.

### *Data Analysis*

Preliminary analyses and evaluations of the intervention's impact on primary outcomes, secondary outcomes, and potential mechanisms were conducted using SPSS 20 software. A series of Mixed-Model ANOVA and Mixed-Model ANCOVA analyses were performed, followed by Sidak post-hoc tests. Effect sizes were quantified using partial eta squared ( $\eta_p^2$ ) and Cohen's  $d$ , wherein values of  $\eta_p^2 = .14$  and  $d = .8$  corresponded to a large effect size,  $\eta_p^2 = .06$  and  $d = .5$  denoted a medium effect size, and  $\eta_p^2 = .01$  and  $d = .2$  indicated a small effect size (Cohen, 2013; Tabachnick & Fidell, 2013).

To examine mediation effects, Structural Equation Modeling (SEM) was employed within the SPSS AMOS 20 software, utilizing Maximum Likelihood (ML) estimation. The bootstrap method was applied to assess longitudinal indirect effects, generating 5000 samples to establish a 95% confidence interval. The significance of effects was determined based on whether the confidence intervals derived from the bootstrap analysis excluded zero (Hayes, 2018; Preacher & Hayes, 2004).

We also used the PRECIS – 2 (Loudon et al., 2015) toolkit to assess how this intervention works in a real-world setting, and therefore to evaluate the applicability of the results. The following nine domains were rated on a five-point scale, ranging from 1 – *very explanatory* to 5 – *very pragmatic*: Eligibility Criteria (5), Recruitment Path (5), Setting (3), Organisation intervention (4), Delivery (5), Adherence (4), Follow up (5), Outcome (5), and Analysis (3). Values in parentheses represent the scores assigned to each domain. Participants in the study were similar to those who would benefit from this intervention (we had no exclusion criteria). Recruitment of participants from the intervention group also did not demand extra effort. Although the intervention setting was similar to the usual care setting (academic setting), we did not include more academic settings in this research. We gave a score of 4 for Organisation, based on the resources and provider expertise required to deliver the CMT intervention. We also gave a score of 5 for flexibility of implementation (for example, there was a 2-week break during the holiday period). Our evaluation also showed a high degree of flexibility in terms of adherence (similar to the flexibility of usual care). In terms of the Follow-up and Primary outcome, we also rated this study as pragmatic rather than explanatory, but we scored pragmatism lower based on the primary analyses.

**Table 1.** Outline of the 12-week CMT group for students (CMT)

Session	Content	Practices	Home Practices
1	Exploration of the model, defining compassion Reality checks concerning suffering Understanding the concept of the „tricky brain” Building capacities for compassion	Compassionate Landing Mindfulness of breath Mindfulness of body sensations Mindfulness of thoughts	Compassionate Landing Reflections
2	Exploration of the three emotion regulation systems (i.e., threat, drive, and soothing), and the importance of balance between them	Compassionate Landing Three Emotional System Visualisation The Exploration of the Three Emotion Systems in Personal Life (Global)	Compassionate Landing The Exploration of the Three Emotion System in Personal Life (Day by Day) Reflections
3	Conceptualization of one’s own situation and reflection Identifying primary fears, coping strategies, and unexpected outcomes Building compassionate motivation	Compassionate Landing Conceptualization of own situation Public Speech Visualisation Soothing Rhythm Breathing Calming Smile, Touch, and Internal Voice	Soothing Rhythm Breathing Conceptualization of own situation Reflections
4	Building compassionate motivation Exploring the concept of compassion and its attributes Delving into the dual psychologies underlying compassion	Compassionate Landing Contemplating the realities of life Compassionate Place Compassionate Color	Soothing Rhythm Breathing Compassionate Place Reflections
5	Unraveling the notion of multiple selves Compassion as Flow – directing compassion to others Addressing fears, blocks, and resistance	Compassionate Landing Compassionate Memory – Feeling Compassion for Others Compassionate Self – Acting and Embodiment „He/ She is just like me”	Compassionate Self – Acting and Embodiment Displaying compassion in everyday life Reflections
6	Compassion as Flow – embracing compassion from others Addressing fears, blocks, and resistance	Compassionate Landing Memories of Compassionate Others Compassionate Creature Role Play	Observing and describing the compassionate attitudes of others Reflections
7	Compassion as Flow – focusing on self-compassion Discussing fears, blocks, and resistance	Compassionate Landing The Compassionate Self helps the other Self who is suffering Mirror practice Writing a compassionate letter to the Self	Compassionate Self – Acting and Embodiment Self-Compassion Journal Reflections

*Articles Section*

<b>Session</b>	<b>Content</b>	<b>Practices</b>	<b>Home Practices</b>
8	Recapitulating the three emotional regulation systems (i.e., threat-, drive- and soothing systems) Learning about the three directions of compassion	Compassionate Landing The Exploration of the Three Emotion System in the Last Week The Compassionate Self helps the other Self who is suffering „He/ She is just like me” Role Play	Compassionate Self – Acting and Embodiment Displaying Compassion in Everyday Life Observing and Describing the Compassionate Attitudes of Others Reflections
9	Discussing the concept of multiple selves Exploring different emotional reactions, and directing compassion towards them	Compassionate Landing „Multiple Selves” exercise	Compassionate Self – Acting and Embodiment Self-Compassion Journal Reflections
10	Exploring the functions of self-criticism and shame, and directing compassion towards it	Compassionate Landing Directing Compassion Towards Shame Awareness of the Inner Critic Two Teachers The Compassionate Self helps the Inner Critic Multiple Self Exercise	Compassionate Self – Acting and Embodiment Self-Compassion Journal Reflections
11	Using the compassionate mind in the context of work and study	Compassionate Landing Compassion Towards Shame Compassionate Letter Awareness of the Inner Critic Replacing shame-based self-criticism with compassionate self-correction The ideal teacher/boss „Multiple Selves” exercise	Compassionate Self – Acting and Embodiment Self-Compassion Journal Reflections
12	Sustaining the compassionate mind and reviewing the model	Compassionate Landing Contemplating the realities of life The Exploration of the Three Emotion Systems in Personal Life (Global) The Future Compassionate Self My new compassionate story	

## Results

### *Preliminary analyses*

Based on skewness and kurtosis, all investigated variables exhibited a normal distribution across every time point. The descriptive statistics for both groups during each time point are presented in Table 2.

**Table 2.** Descriptive Statistics

	T1 <i>M (SD)</i>		T2 <i>M (SD)</i>		T3 <i>M (SD)</i>		T4 <i>M (SD)</i>	
	CMT ( <i>n</i> = 45)	Control ( <i>n</i> = 21)	CMT ( <i>n</i> = 45)	Control ( <i>n</i> = 21)	CMT ( <i>n</i> = 45)	Control ( <i>n</i> = 21)	CMT ( <i>n</i> = 45)	Control ( <i>n</i> = 21)
<b>Negative Affect</b>	36.64 (9.36)	30.14 (9.76)	31.37 (9.72)	28.90 (8.62)	30.53 (8.38)	32.09 (9.54)	28.02 (9.43)	30.95 (12.47)
<b>Depression</b>	15.51 (10.43)	9.71 (9.25)	11.2 (8.79)	10.19 (6.86)	7.51 (6.70)	11.04 (8.52)	7.95 (7.77)	12.09 (8.25)
<b>Anxiety</b>	16.53 (8.74)	16.57 (11.59)	15.11 (9.32)	14.00 (11.91)	11.82 (7.97)	14.19 (12.61)	10.13 (7.83)	13.52 (12.13)
<b>Stress</b>	24.4 (8.41)	16.76 (7.68)	20.75 (8.99)	19.14 (10.89)	18.93 (10.05)	20.66 (11.52)	15.77 (8.23)	19.14 (10.66)
<b>Soothing Positive Affect</b>	13.95 (2.13)	14.52 (3.29)	14.51 (2.62)	14.85 (2.30)	14.40 (2.60)	14.14 (2.63)	15.17 (2.48)	14.19 (3.85)
<b>Activating Positive Affect</b>	26.00 (5.58)	26.80 (4.42)	24.84 (4.91)	26.23 (5.30)	25.04 (5.83)	24.14 (7.09)	27.02 (5.12)	24.95 (6.05)
<b>Life Satisfaction</b>	24.4 (8.41)	25.90 (6.01)	24.55 (5.57)	25.47 (5.83)	25.26 (5.70)	25.42 (4.92)	25.86 (6.12)	25.42 (4.92)
<b>Self-Compassion</b>	2.82 (.55)	3.07 (.69)	3.19 (.65)	3.05 (.60)	3.50 (.50)	3.13 (.58)	3.43 (.61)	3.11 (.77)
<b>Self-Coldness</b>	3.68 (.68)	3.11 (.85)	3.22 (.72)	3.19 (.73)	2.93 (.72)	3.00 (.65)	2.92 (.74)	3.11 (.82)
<b>Self-Warmth</b>	3.33 (.64)	3.26 (.76)	3.60 (.72)	3.30 (.59)	3.94 (.51)	3.26 (.63)	3.79 (.68)	3.34 (.85)
<b>Dysfunctional Attitudes</b>	-8.88 (13.83)	-3.90 (17.70)	-12.42 (15.05)	-6.61 (16.26)	-21.35 (14.76)	-6.57 (19.74)	-20.13 (14.09)	-3.95 (21.06)

During the initial assessment, no differences were found between individuals who successfully responded to the questionnaires ( $n = 66$ ) and those who did not ( $n = 58$ ) across any of the variables measured at all time points. However, upon examining the distinctions in baseline characteristics between the CMT group and the control group, notable discrepancies emerged in four variables. Specifically, the CMT group reported higher levels of negative affect (moderate difference), depression (moderate difference), stress (large difference), and self-coldness (medium to large difference) compared to participants in the control group.

Therefore, regarding negative affect, depression, stress, and self-coldness mixed-model ANCOVA tests were performed, in order to control the baseline differences between the two groups (variables measured at baseline were introduced in our models as a covariates). Conversely, no significant differences between the two groups were observed in other measured variables such as anxiety, soothing positive affect, activating positive affect, life satisfaction, self-compassion, self-warmth, and dysfunctional attitudes (refer to Table 3), therefore in these cases, mixed ANOVA tests were performed.

**Table 3.** Differences in measured variables between CMT and control groups at baseline

Variable	CMT Group (n = 45)		Control Group (n = 21)		t(64)	p	Cohen's d
	M	SD	M	SD			
Age	20.17	1.54	20.09	.76	.23	.81	.06
Negative Affect	36.64	9.36	30.14	9.76	2.59	.01	.67
Depression	15.51	10.43	9.71	9.25	2.17	.03	.58
Anxiety	16.53	8.74	16.57	11.59	-.01	.98	.003
Stress	24.4	8.41	16.76	7.68	3.52	.001	.94
Soothing Positive Affect	13.95	2.13	14.52	3.29	-.72	.47	.20
Activating Positive Affect	26.00	5.58	26.80	4.42	-.58	.56	.15
Life Satisfaction	24.4	8.41	25.90	6.01	-.99	.32	.20
Self-Compassion	2.82	.55	3.07	.69	-1.59	.11	.40
Self-Coldness	3.68	.68	3.11	.85	2.89	.005	.74
Self-Warmth	3.33	.64	3.26	.76	.35	.72	.09
Dysfunctional Attitudes	-8.88	13.83	-3.90	17.70	-1.24	.218	.31

*Effectiveness of the intervention on primary outcomes*

We first tested the effects on the primary outcomes, negative and soothing positive affect. Regarding negative affect (see Figure 2), a mixed-model ANCOVA test was performed, in order to control the baseline differences between the two groups (negative affect measured at baseline was introduced in our model as a covariate). Mauchly's test of sphericity yielded a significant result, prompting the presentation of time and time-group interaction effects with Huynh-Feldt correction (Epsilon for Greenhouse-Geisser = .83; Epsilon for Huynh-Feldt = .88). The time had no effect on negative affect,  $F(1,76) = .726, p = .47, \eta_p^2 = .011$ , (nor when we examined independently within each group), but the interaction between time and group had significant effect on it,  $F(1,76) = 3.21, p = .05, \eta_p^2 = .048$ . The group effect on negative affect was also significant,  $F(1) = 4.91, p = .03, \eta_p^2 = .072$ .

Sidak pairwise comparisons indicated significant large difference between the CMT ( $M_{estimated} = 29.48$ ;  $SE = 1.11$ ) and the control group ( $M_{estimated} = 34.34$ ;  $SE = 1.66$ ) at post-test ( $M_{diff} = 4.86$ ,  $SE = 2.04$ ,  $p = .02$ ,  $d = .82$ ). The differences between the CMT ( $M_{estimated} = 26.84$ ;  $SE = 1.37$ ) and the control group ( $M_{estimated} = 33.47$ ;  $SE = 2.04$ ) was also significant and large at 3-months follow-up ( $M_{diff} = 6.63$ ,  $SE = 2.51$ ,  $p = .01$ ,  $d = .94$ ).

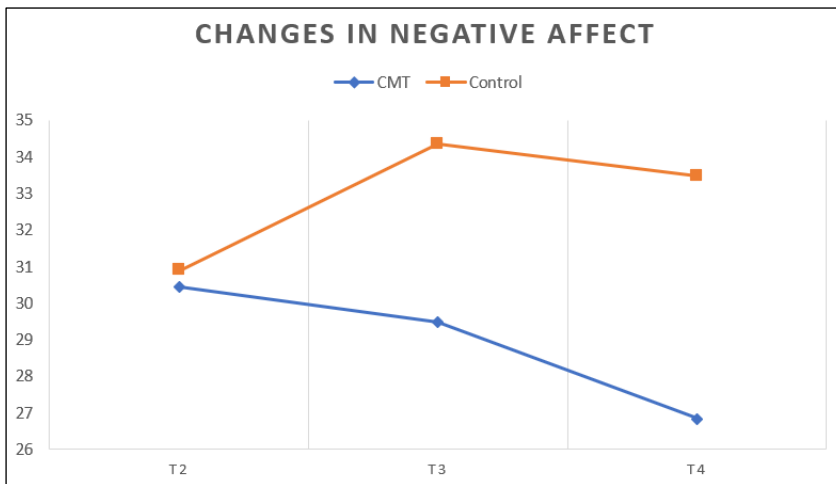
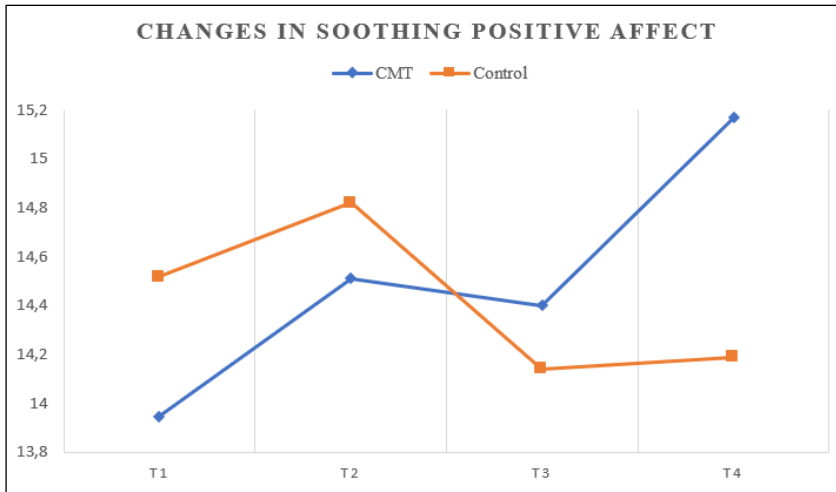

**Figure 2.** Results for Negative Affect with Estimated Marginal Means

*Notes.* Covariates appearing in the model are evaluated at the following values: T1NegativeAffect = 34.57

Concerning soothing positive affect, Mauchly's test of sphericity yielded significance as well, necessitating the application of Huynh-Feldt correction for reporting time and time- group effects (Epsilon for Greenhouse-Geisser = .89; Epsilon for Huynh-Feldt = .95). However, no significant effect emerged for soothing positive affect.

In terms of the levels of soothing positive affect, no intergroup differences were apparent across any of the time points. However, when examined independently within each group, multivariate tests revealed that the impact of time on soothing positive affect was present exclusively in the CMT group, Wilk's  $\lambda = .87$ ,  $F(3) = 2.84$ ,  $p = .04$ ,  $\eta_p^2 = .12$ , representing a medium to large effect, while the control group did not exhibit this effect, Wilk's  $\lambda = .96$ ,  $F(3) = .79$ ,  $p = .49$ ,  $\eta_p^2 = .03$ . The illustrated pattern of results is depicted in Figure 3 as well.



**Figure 3.** Results for Soothing Positive Affect

Pairwise comparisons revealed notable differences with a medium effect size within the CMT group regarding levels of soothing positive affect, showcasing a significant difference between baseline ( $M = 13.95$ ,  $SD = 2.13$ ) and follow-up ( $M = 15.17$ ,  $SD = 2.48$ ;  $M_{diff} = 1.22$ ,  $SE = .43$ ,  $p = .04$ ,  $d = .52$ ) assessments.

#### *Effectiveness of the intervention on secondary outcomes*

Regarding depression, a mixed-model ANCOVA test was performed, in order to control the baseline differences between the two groups (depression measured at baseline was introduced in our model as a covariate). In terms of depression, Mauchly's test of sphericity did not yield a significant result ( $p = .63$ ), implying that sphericity could be assumed.

We found significant effect of group on depression,  $F(1) = 7.89$ ,  $p < .01$ ,  $\eta_p^2 = .11$ . However, no significant effect emerged for the time,  $F(2) = .358$ ,  $p = .70$ ,  $\eta_p^2 = .006$ , nor for the time and group interaction,  $F(2) = 2.18$ ,  $p = .11$ ,  $\eta_p^2 = .03$ . When examined independently within each group, multivariate tests revealed that the impact of time on depression was present exclusively in the CMT group, where a reduction in depression was observed from mid-test ( $M_{estimated} = 10.49$ ,  $SE = 1.10$ ) to post-test ( $M_{estimated} = 7.18$ ,  $SE = 1.08$ ,  $M_{diff} = -3.30$ ,  $SE = 1.29$ ,  $p = .039$ ), and maintaining stability through the follow-up period ( $M_{estimated} = 7.32$ ,  $SE = 1.08$ ,  $M_{diff} = .13$ ,  $SE = 1.27$ ,  $p = .99$ ). Depression levels within the control group remained consistent across all time points. Regarding depression levels, significant differences emerged between groups at the post-test with medium effect size ( $M_{diff} = 4.54$ ,  $SE = 1.96$ ,  $p < .05$ ,  $d = .66$ ) and at the follow-up with a large effect size ( $M_{diff} = 6.13$ ,

$SE = 1.96, p < .01, d = .99$ ). The illustrated pattern of results is depicted in Figure 4 as well.

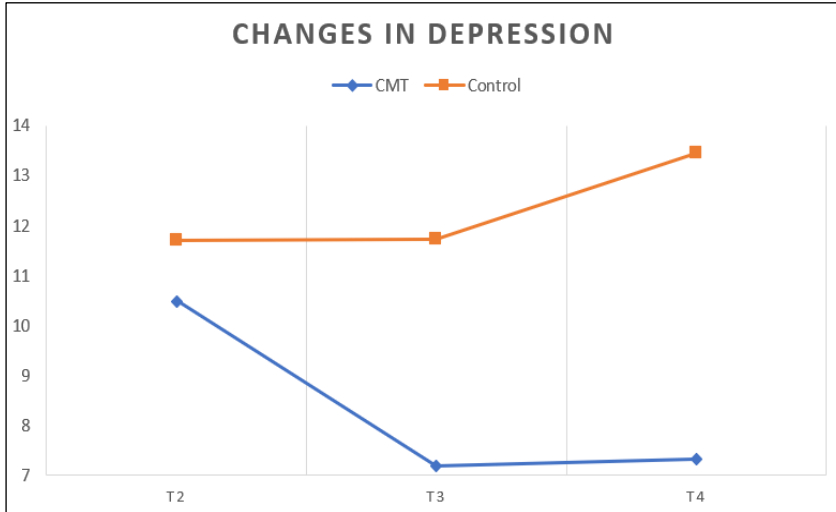
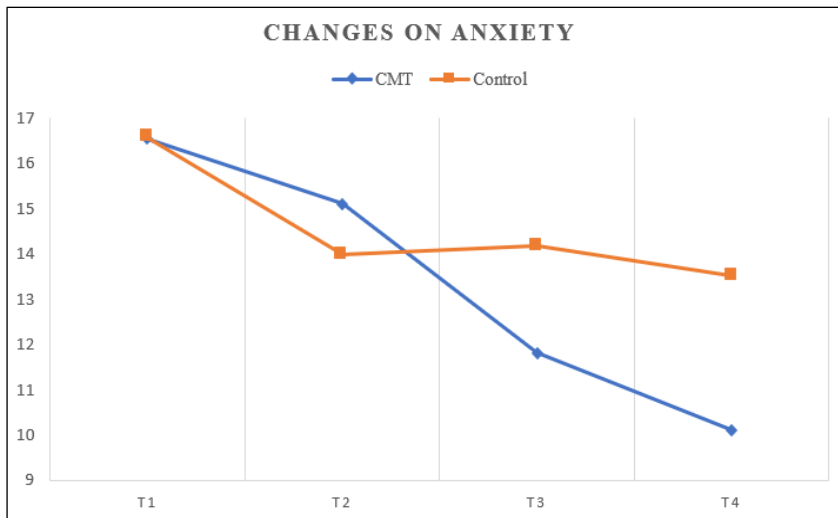

**Figure 4.** Results for Depression with Estimated Marginal Means

*Notes.* Covariates appearing in the model are evaluated at the following values: T1Depression = 13.66

Concerning anxiety, the assumption of sphericity was justified based on the non-significant outcome of Mauchly's test ( $p = .49$ ). A significant medium effect attributed to time was identified in relation to anxiety,  $F(3) = 5.75, p < .01, \eta_p^2 = .08$ . However, neither the group variable,  $F(1) = .30, p = .58, \eta_p^2 = .01$ , nor the interaction between time and group exhibited an effect,  $F(3) = 1.47, p = .22, \eta_p^2 = .02$ .

No differences emerged between the two groups at any of the time points. However, upon analysing separately the change in anxiety amongst the individual groups, a significant change of large effect size was observed exclusively within the CMT group, denoted by Wilk's  $\lambda = .28, F(3) = 8.02, p < .01, \eta_p^2 = .28$ , whereas no such change was apparent in the control group, Wilk's  $\lambda = .95, F(3) = 1.04, p = .38, \eta_p^2 = .05$ . Within the CMT group, anxiety levels remained consistent from baseline ( $M = 16.53, SD = 8.74$ ) to mid-test ( $M = 15.11, SD = 9.32, M_{diff} = -1.42, SE = 1.27, p = .84$ ), but decreased from baseline to post-test ( $M = 11.82, SD = 7.97, M_{diff} = -4.71, SE = 1.41, p < .01, d = .37$ ), and remained unchanged from post-test to follow-up ( $M = 10.13, SD = 7.83, M_{diff} = -1.68, SE = 1.29, p = .73$ ). Results for anxiety are also presented in Figure 5.



**Figure 5.** Results for Anxiety

Regarding stress, a mixed-model ANCOVA test was performed, in order to control the baseline differences between the two groups (stress measured at baseline was introduced in our model as a covariate). Due to the significant outcome of Mauchly's test ( $p = .015$ ), it was not appropriate to assume sphericity. Consequently, we reported both time and time\*group interaction effects with the Huynh-Feldt correction (Epsilon for Greenhouse-Geisser = .88; Epsilon for Huynh-Feldt = .94). No significant time,  $F(1,88) = .46, p = .61, \eta_p^2 = .007$ , nor time and group interaction effect,  $F(1,88) = 1.79, p = .17, \eta_p^2 = .10$ , were found on stress. However, the group had significant effect on stress,  $F(1) = 9.27, p < .01, \eta_p^2 = .128$ .

Regarding stress, controlled for the initial stress levels, significant large differences emerged between groups at the post-test ( $M_{diff} = 6.92, SE = 2.60, p = .01, d = .94$ ) and also at the follow-up ( $M_{diff} = 7.40, SE = 2.31, p < .01, d = 1.15$ ). Examining the effect of time on stress independently within each group, multivariate tests revealed that the impact of time on stress was present exclusively in the CMT group, Wilk's  $\lambda = .86, F(2) = 4.75, p = .01, \eta_p^2 = .13$ , representing a medium to large effect, while the control group did not exhibit this effect, Wilk's  $\lambda = .85, F(2) = .85, p = .43, \eta_p^2 = .027$ . These results mean that stress levels within the control group remained consistent across all time points. However, noteworthy changes occurred within the CMT group, where a reduction in stress was observed from mid-test ( $M_{estimated} = 19.45, SE = 1.32$ ) to the follow-up period ( $M_{estimated} = 14.49, SE = 1.23, M_{diff} = 4.96, SE = 1.64, p = .01$ ). Results are presented in Figure 6 as well.

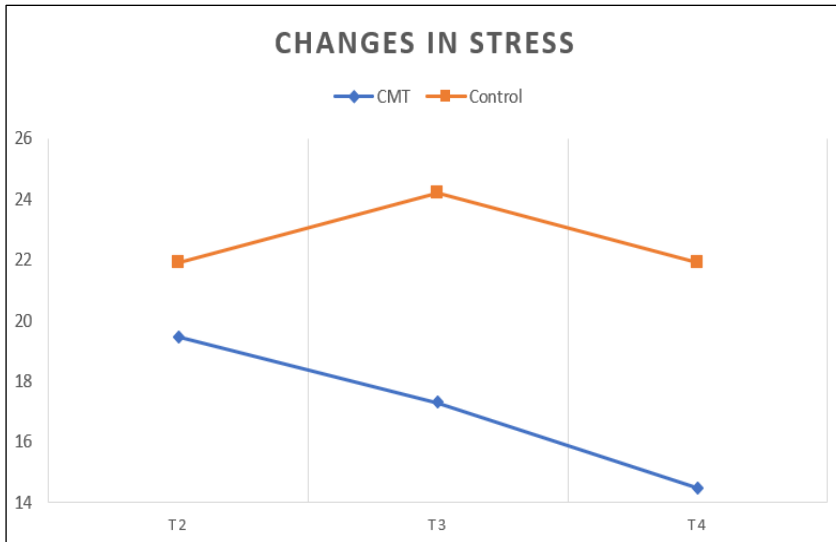
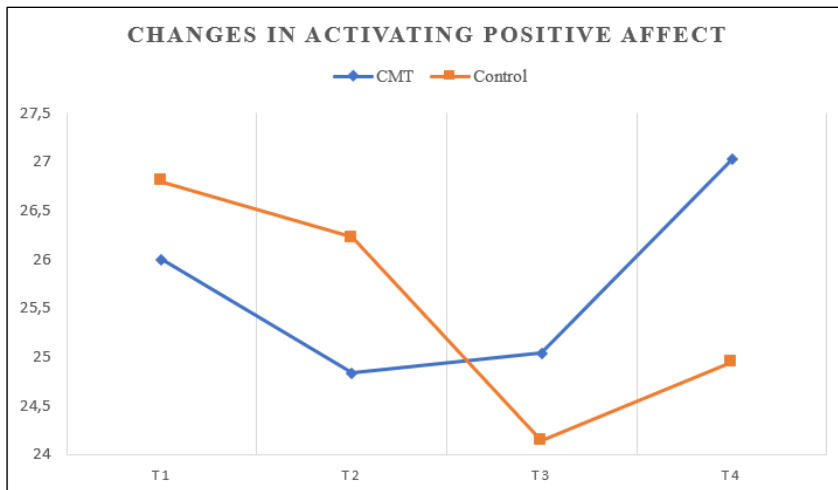

**Figure 6.** Results for Stress with Estimated Marginal Means

*Notes.* Covariates appearing in the model are evaluated at the following values: T1Stress = 21.96

Given the non-assumption of sphericity for activating positive affect ( $p = .02$ ), we proceeded to report time and time\*group effects employing the Huynh-Feldt correction (Epsilon for Greenhouse-Geisser = .87; Epsilon for Huynh-Feldt = .93). However, neither of the effects exhibited significance for activating positive affect: this includes the time effect,  $F(2,79) = 2.38$ ,  $p = .07$ ,  $\eta_p^2 = .03$ , the time and group interaction,  $F(2,79) = 2.49$ ,  $p = .06$ ,  $\eta_p^2 = .037$ , as well as the group effect,  $F(1) = .02$ ,  $p = .87$ ,  $\eta_p^2 = .00$ .

Analyzing the changes across time separately for the two groups, we found a significant and large time effect for the CMT group, Wilk's  $\lambda = .86$ ,  $F(3) = 3.29$ ,  $p = .02$ ,  $\eta_p^2 = .13$ , contrasting with the control group, where no such effect emerged, Wilk's  $\lambda = .90$ ,  $F(3) = 2.06$ ,  $p = .11$ ,  $\eta_p^2 = .09$  (see also Figure 7). Within the CMT group, the sole significant difference occurred between the mid-test measurement ( $M = 24.84$ ,  $SD = 4.91$ ) and follow-up measurement ( $M = 27.02$ ,  $SD = 5.12$ ,  $M_{diff} = 2.17$ ,  $SE = .71$ ,  $p = .02$ ,  $d = .43$ ). No differences were found between the groups at any time point.



**Figure 7.** Results for Activating Positive Affect

Concerning life satisfaction, given the non-significant outcome of Mauchly's test ( $p = .08$ ), we proceeded with the assumption of sphericity. Our analysis indicated the absence of a time effect,  $F(3) = 1.52$ ,  $p = .20$ ,  $\eta_p^2 = .02$ , no interaction effect between time and group was detected,  $F(3) = .69$ ,  $p = .55$ ,  $\eta_p^2 = .01$ , and no group effect was identified,  $F(3) = .29$ ,  $p = .59$ ,  $\eta_p^2 = .01$ .

No differences were found between groups in any of the time points, and time effects remained non-significant even when analyzed separately for each of the two groups.

#### *Effectiveness of the intervention on investigated mechanisms*

We also tested the effectiveness of the intervention on possible mechanisms (self-compassion, self-coldness, self-warmth, and dysfunctional attitudes). Regarding self-compassion, based on Mauchly's non-significant test results ( $p = .16$ ), sphericity was assumed. We found a significant and large time effect,  $F(3) = 11.59$ ,  $p < .01$ ,  $\eta_p^2 = .15$ , a significant and medium time and group interaction effect,  $F(3) = 8.27$ ,  $p < .01$ ,  $\eta_p^2 = .11$ , but no significant group effect,  $F(1) = 1.08$ ,  $p = .30$ ,  $\eta_p^2 = .01$ .

Multivariate analyses indicated a significant time effect with a large effect size exclusively in the CMT group, Wilk's  $\lambda = .37$ ,  $F(3) = 34.69$ ,  $p < .01$ ,  $\eta_p^2 = .62$ , whereas no such effect was observed in the control group, Wilk's  $\lambda = .98$ ,  $F(3) = .23$ ,  $p = .87$ ,  $\eta_p^2 = .01$ . In the control group, self-compassion levels remained consistent across all time points. Conversely, students in the CMT group experienced an increase in self-compassion levels from baseline ( $M = 2.82$ ,  $SD = .55$ ) to the mid-

test ( $M = 3.19$ ,  $SD = .65$ ,  $M_{diff} = .37$ ,  $SE = .08$ ,  $p < .01$ ,  $d = .61$ ). This upward trend continued from the mid-test to the post-test ( $M = 3.5$ ,  $SD = .50$ ,  $M_{diff} = .31$ ,  $SE = .07$ ,  $p < .01$ ,  $d = .53$ ), and these levels remained stable from the post-test to the follow-up ( $M = 3.43$ ,  $SD = .61$ ,  $M_{diff} = -.07$ ,  $SE = .07$ ,  $p = .91$ ). A difference in self-compassion emerged between the two groups during the post-test ( $M_{diff} = .375$ ,  $SE = .140$ ,  $p < .01$ ,  $d = .68$ ). However, these differences were no longer significant at the follow-up assessment ( $M_{diff} = .314$ ,  $SE = .176$ ,  $p = .08$ ,  $d = .46$ ). For these results, see also Figure 8.

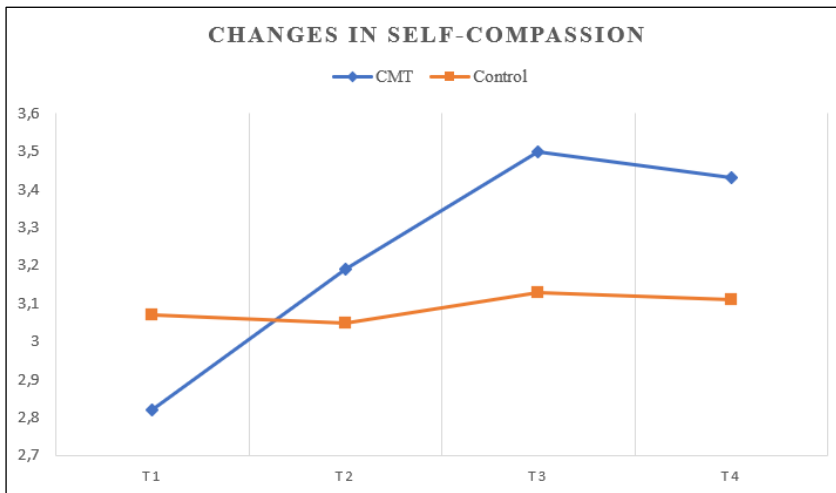
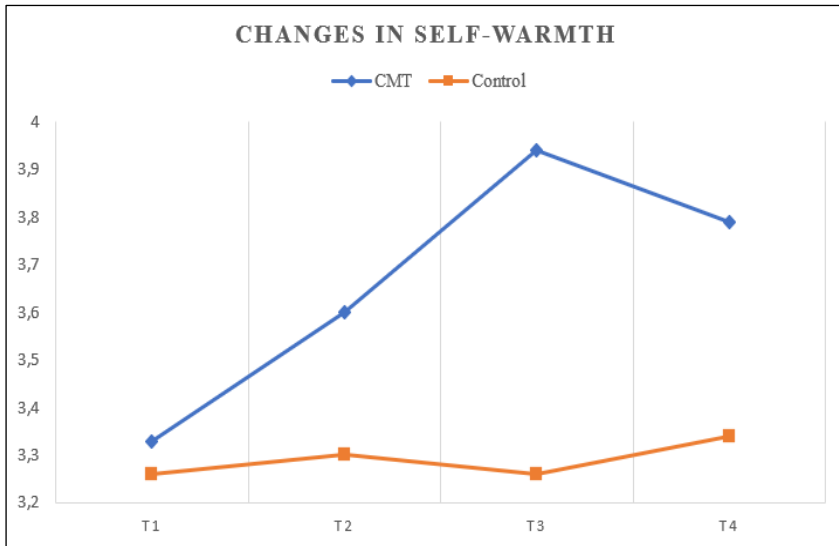

**Figure 8.** Results for Self-Compassion

The results for self-warmth were similar to the results for self-compassion (see Figure 9). Mauchly's sphericity test did not produce a significant result (Mauchly's  $W = .91$ ,  $df = 5$ ,  $p = .34$ ), indicating that we could assume sphericity. Significant medium effects were observed for time,  $F(3) = 6.43$ ,  $p < .01$ ,  $\eta_p^2 = .09$ , the interaction of time and group,  $F(3) = 5.77$ ,  $p < .01$ ,  $\eta_p^2 = .08$ , and group,  $F(1) = 6.18$ ,  $p < .01$ ,  $\eta_p^2 = .08$ .

Regarding self-warmth levels, large significant differences emerged between groups at the post-test ( $M_{diff} = .68$ ,  $SE = .14$ ,  $p < .01$ ,  $d = 1.18$ ), and medium divergences were observed at follow-up ( $M_{diff} = .44$ ,  $SE = .19$ ,  $p = .02$ ,  $d = .58$ ). For participants in the control group, self-warmth remained constant across the four measurement time points, with time having no effect (Wilk's  $\lambda = .98$ ,  $F(3) = .23$ ,  $p = .87$ ,  $\eta_p^2 = .01$ ), as opposed the CMT group, where a significant large time effect was found (Wilk's  $\lambda = .48$ ,  $F(3) = 22.02$ ,  $p < .01$ ,  $\eta_p^2 = .51$ ). The pattern of change mirrored that of self-compassion, with self-warmth increasing from baseline ( $M = 3.33$ ,  $SD = .64$ ) to the mid-test ( $M = 3.60$ ,  $SD = .72$ ,  $M_{diff} = .27$ ,

$SE = .09$ ,  $p = .03$ ,  $d = .39$ ), continuing to increase from mid-test to post-test ( $M = 3.94$ ,  $SD = .51$ ,  $M_{diff} = .33$ ,  $SE = .08$ ,  $p < .01$ ,  $d = .54$ ), and remaining stable through follow-up ( $M = 3.79$ ,  $SD = .68$ ,  $M_{diff} = -.14$ ,  $SE = .08$ ,  $p = .36$ ).

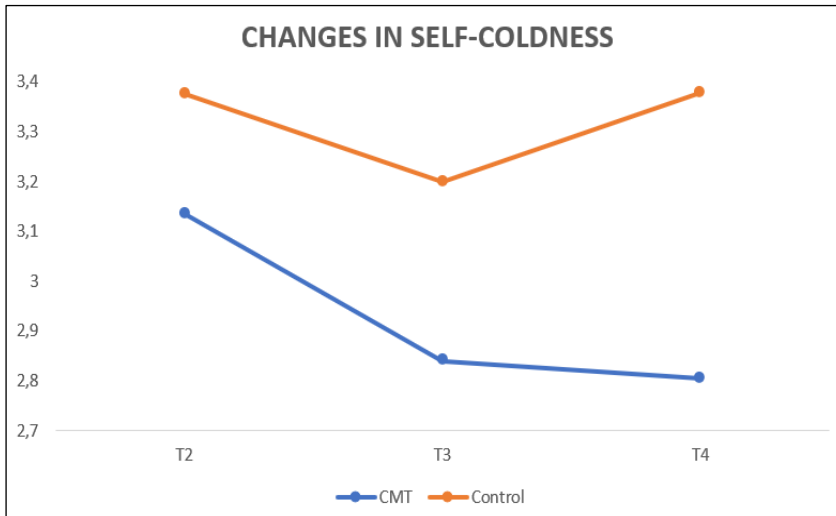

**Figure 9.** Results for Self-Warmth

Regarding self-coldness, a mixed-model ANCOVA test was performed, in order to control the baseline differences between the two groups (self-coldness measured at baseline was introduced in our model as a covariate). For self-coldness the sphericity was assumed (Mauschly's  $W = .92$ ,  $df = 2$ ,  $p = .07$ ). We found a significant time effect,  $F(2) = 3.30$ ,  $p = .04$ ,  $\eta_p^2 = .05$ , but no time and group interaction effect was identified,  $F(2) = 1.97$ ,  $p = .14$ ,  $\eta_p^2 = .03$ . The group effect was also significant,  $F(1) = 7.93$ ,  $p < .01$ ,  $\eta_p^2 = .112$  (see also Figure 10).

Examining the effect of time on self-coldness independently within each group, multivariate tests revealed that the impact of time on self-coldness was present exclusively in the CMT group, Wilk's  $\lambda = .79$ ,  $F(2) = 8.01$ ,  $p = .001$ ,  $\eta_p^2 = .20$ , representing a large effect, while the control group did not exhibit this effect, Wilk's  $\lambda = .95$ ,  $F(2) = 1.46$ ,  $p = .24$ ,  $\eta_p^2 = .04$ . These results mean that self-coldness levels within the control group remained consistent across all time points. However, noteworthy changes occurred within the CMT group, where a reduction in self-coldness was observed from mid-test ( $M_{estimated} = 3.13$ ,  $SE = .09$ ) to post-test ( $M_{estimated} = 2.84$ ,  $SE = .09$ ,  $M_{diff} = -.29$ ,  $SE = .08$ ,  $p = .001$ ), and maintaining

stability through the follow-up period ( $M_{estimated} = 2.80$ ,  $SE = .08$ ,  $M_{diff} = .03$ ,  $SE = .09$ ,  $p = .97$ ).

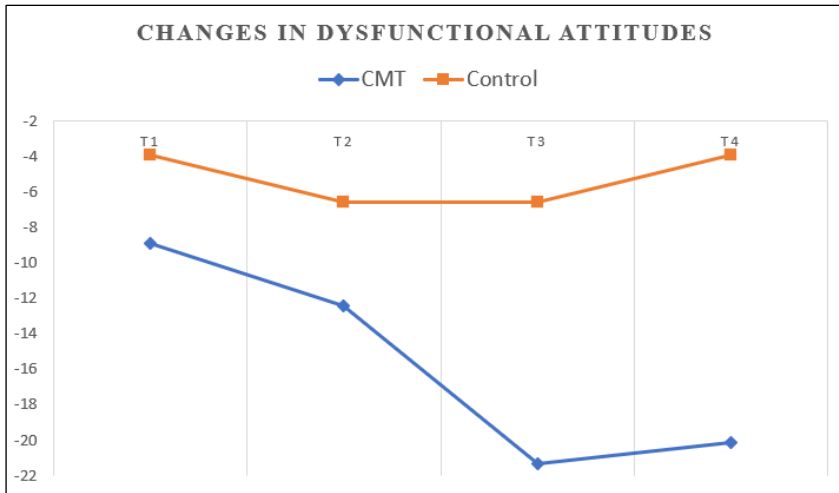

**Figure 10.** Results for Self-Coldness with Estimated Marginal Means

*Notes.* Covariates appearing in the model are evaluated at the following values: T1Self-Coldness = 3.50

Regarding self-coldness, controlled for the initial self-coldness levels, significant differences emerged between groups at the post-test with a medium effect size ( $M_{diff} = .359$ ,  $SE = .168$ ,  $p = .037$ ,  $d = .59$ ) and at the follow-up we found large differences ( $M_{diff} = .574$ ,  $SE = .163$ ,  $p < .01$ ,  $d = .97$ ).

Last, we examined the impact on dysfunctional attitudes, the results of which are presented in Figure 11. Sphericity was not assumed for dysfunctional attitudes (Mauschly's  $W = .79$ ,  $df = 5$ ,  $p = .01$ ) facilitating the report of time and time\*group effects utilising the Huynh-Feldt correction (Epsilon for Greenhouse-Geisser = .87, Epsilon for Huynh-Feldt = .93). Significant medium-sized effects were identified, including time effect,  $F(2,79) = 6.89$ ,  $p < .01$ ,  $\eta_p^2 = .09$ , time and group interaction effect,  $F(2,79) = 5.52$ ,  $p < .01$ ,  $\eta_p^2 = .07$ , as well as group effect,  $F(1) = 8.34$ ,  $p < .01$ ,  $\eta_p^2 = .11$ .



**Figure 11.** Results for Dysfunctional Attitudes

Pairwise comparisons revealed significant and large differences in dysfunctional attitudes during the post-test ( $M_{diff} = 14.78$ ,  $SE = 4.35$ ,  $p < .01$ ,  $d = .84$ ), and follow-up ( $M_{diff} = 16.18$ ,  $SE = 4.38$ ,  $p < .01$ ,  $d = .90$ ) assessments. Large-scale time effects were also observed solely within the CMT group, Wilk's  $\lambda = .56$ ,  $F(3) = 16.12$ ,  $p < .01$ ,  $\eta_p^2 = .43$ , while no such effects were noticed in the control group, Wilk's  $\lambda = .97$ ,  $F(3) = .55$ ,  $p = .64$ ,  $\eta_p^2 = .02$ .

The levels of dysfunctional attitudes for participants belonging to the CMT group remained consistent from baseline ( $M = -8.88$ ,  $SD = 13.83$ ) to mid-test ( $M = -12.42$ ,  $SD = 15.05$ ,  $M_{diff} = -3.53$ ,  $SE = 1.89$ ,  $p = .33$ ), decreased from mid-test to post-test ( $M = -21.35$ ,  $SD = 14.76$ ,  $M_{diff} = -8.93$ ,  $SE = 1.53$ ,  $p < .01$ ,  $d = .59$ ), and maintained stability from post-test to follow-up ( $M = -20.13$ ,  $SD = 14.09$ ,  $M_{diff} = 1.22$ ,  $SE = 1.87$ ,  $p = .98$ ).

#### *Testing of mechanisms of the intervention on negative affect*

For testing the longitudinal mediation effects, we tested indirect effects based on the model presented in Figure 12. Given that we found baseline differences between groups, we also controlled for the effect of the group on variables at the baseline level. Based on Goldsmith and colleagues' (2018) recommendations, we additionally controlled for contemporaneous covariance between mediator and outcome.

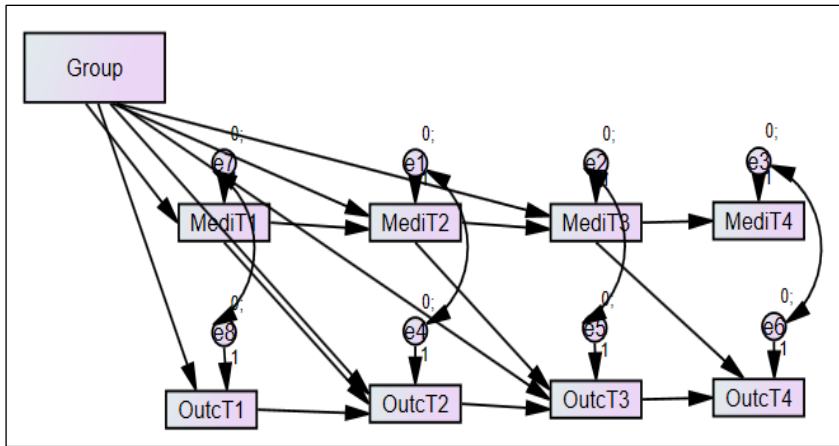

**Figure 12.** Tested model for longitudinal mediation analyses

The effect of the group on primary outcomes (negative affect and soothing positive affect) was examined through the hypothesized mediators: self-compassion, self-coldness, self-warmth, and dysfunctional attitudes. In Figure 13, we have displayed the specific indirect effects that were of particular interest to us.

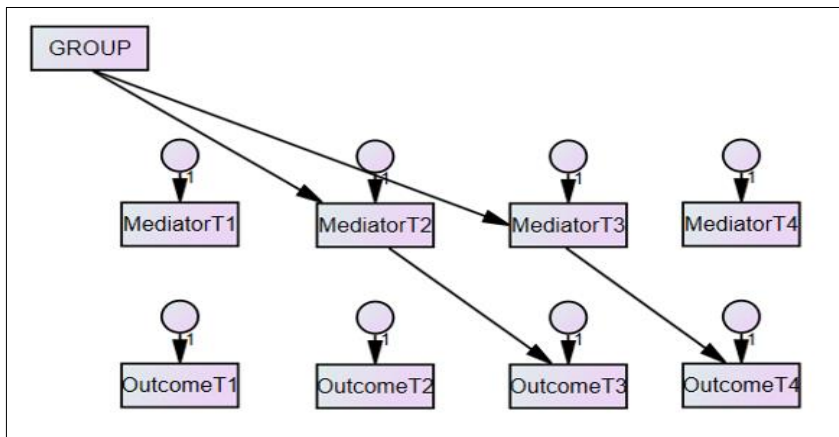

**Figure 13.** Tested indirect effects

Our initial analysis focused on examining the longitudinal indirect effects on negative affect. The results indicate that the standardized indirect effect of the group on negative affect, as measured through indirect paths, was not statistically significant. The detailed results can be found in Table 4.

**Table 4** Standardized indirect effects on negative affect

Predictor	Mediator	Effect type	Outcome	Standardized Indirect Effects	95% CI	
					LL	UL
Group	T2Self-compassion	Indirect	T3NegativeA	-.06	-.22	.09
Group	T3Self-compassion	Indirect	T4NegativeA	.10	-.06	.28
Group	T2Self-coldness	Indirect	T3NegativeA	-.07	-.22	.08
Group	T3Self-coldness	Indirect	T4NegativeA	.05	-.11	.21
Group	T2Self-warmth	Indirect	T3NegativeA	-.08	-.24	.07
Group	T3Self-warmth	Indirect	T4NegativeA	.07	-.09	.26
Group	T2Dysfunctional Attitudes	Indirect	T3NegativeA	-.06	-.23	.11
Group	T3Dysfunctional Attitudes	Indirect	T4NegativeA	.06	-.12	.24

Notes: \*\* The regression is significant at the .01 level; CI Confidence Interval; LL Lower Limit; UL Upper Limit; NegativeA Negative Affect

These results indicate that self-compassion levels assessed during mid-intervention did not mediate the effect of the group towards the volume of negative affect measured at post-test ( $\beta = -.06$ , 95%CI =  $-.22$  to  $.09$ ). Moreover, self-compassion levels assessed during post-test did not mediate the effect of the group towards the degree of negative affect measured at the three- month follow-up ( $\beta = .10$ , 95%CI =  $-.06$  to  $.28$ ).

Additionally, when examined, the separate mediating effects of self-coldness and self- warmth indicate that neither self-coldness at mid-intervention ( $\beta = -.07$ , 95%CI =  $-.22$  to  $.08$ ) nor self-coldness at post-test ( $\beta = .05$ , 95%CI =  $-.11$  to  $.21$ ) served as significant mediators of the effects. Likewise, self-warmth at mid-intervention ( $\beta = -.08$ , 95%CI =  $-.24$  to  $.07$ ) and self- warmth at post-test ( $\beta = .07$ , 95%CI =  $-.09$  to  $.26$ ) did not emerge as significant mediators. Furthermore, dysfunctional attitudes did not exhibit a significant mediating effect at either the mid-test ( $\beta = -.06$ , 95%CI =  $-.23$  to  $.11$ ) or the post-test ( $\beta = .06$ , 95%CI =  $-.11$  to  $.24$ ).

*Testing of mechanisms of the intervention on soothing positive affect*

We also analyzed the longitudinal indirect effects on soothing positive affect. The results, which can be found in Table 5, indicate that, in the majority of cases, the standardized indirect effect of the group on soothing positive affect through the indirect paths was not statistically significant.

**Table 5** Standardized Indirect Effects of the Group on Soothing Positive Affect

Predictor	Mediator	Effect type	Outcome	Standardized Indirect Effects	95% CI	
					LL	UL
Group	T2Self-compassion	Indirect	T3SoothingPA	.04	-.10	.17
Group	T3Self-compassion	Indirect	T4SoothingPA	-.11	-.25	.01
Group	T2Self-coldness	Indirect	T3SoothingPA	.04	-.11	.17

Predictor	Mediator	Effect type	Outcome	Standardized Indirect Effects	95% CI	
					LL	UL
Group	T3Self-coldness	Indirect	T4SoothingPA	-.02	-.16	.08
Group	T2Self-warmth	Indirect	T3SoothingPA	.06	-.09	.20
Group	T3Self-warmth	Indirect	T4SoothingPA	-.14	-.31	.03
Group	T2Dysfunctional Attitudes	Indirect	T3SoothingPA	.06	-.09	.21
Group	T3Dysfunctional Attitudes	Indirect	T4SoothingPA	-.14	-.29	-.004

Notes: \*\* The regression is significant at the .01 level; CI Confidence Interval; LL Lower Limit; UL Upper Limit; SoothingPA Soothing Positive Affect

The findings regarding soothing positive affect showed that self-compassion at mid- intervention did not mediate the group's effect on soothing positive affect at post-test ( $\beta = .04$ , 95%CI =  $-.10$  to  $.17$ ). Similarly, self-compassion at post-test did not mediate the group's effect on soothing positive affect at the three-month follow-up ( $\beta = -.11$ , 95%CI =  $-.25$  to  $.01$ )

While examining the mediating effects of self-coldness and self-warmth separately, the results revealed that neither self-coldness at mid-intervention ( $\beta = .04$ , 95%CI =  $-.11$  to  $.17$ ) nor self-coldness at post-test ( $\beta = -.02$ , 95%CI =  $-.16$  to  $.08$ ) served as significant mediators. Likewise, self-warmth at mid-intervention ( $\beta = .06$ , 95%CI =  $-.09$  to  $.20$ ) and self-warmth at post-test ( $\beta = -.14$ , 95%CI =  $-.310$  to  $.03$ ) did not demonstrate significant mediation effects.

Although no significant mediating effect was found for dysfunctional attitudes at the mid-test ( $\beta = .06$ , 95%CI =  $-.09$  to  $.21$ ), it was revealed that dysfunctional attitudes measured at the post-test mediated the effect of the group on soothing positive affect at the three-month follow-up ( $\beta = -.14$ , 95%CI =  $-.29$  to  $-.004$ ). This suggests that the group's influence on soothing positive affect, as measured at the follow-up, may be partially explained by dysfunctional attitudes measured at the post-test within an academic setting.

## Discussion

### *The effectiveness of the intervention on primary outcomes*

The current study aimed to assess the effectiveness of the Hungarian adaptation of Compassion Mind Training in a pragmatic trial conducted within an academic setting, targeting undergraduate students' distress and well-being. We focused on assessing its impact on two key outcomes: negative affect and soothing positive affect. In line with previous findings (Beaumont et al., 2021; Irons & Heriot-Maitland, 2021; Matos et al., 2017; Matos et al., 2022), our results demonstrate the intervention's effectiveness in improving affect. Regarding negative affect, a mixed-model ANCOVA test was performed, in order to control the baseline differences

between the two groups. We found large differences between the CMT and the control group at post-test and also at 3-months follow-up. Furthermore, we identified a medium to large effect of time towards soothing positive affect for participants belonging to the CMT group. However, it's noteworthy that we did not find significant differences between the intervention and control groups at any of the assessment time points. This may be attributed, in part, to limitations in statistical power.

Taking these outcomes into account, our first hypothesis was partially confirmed. We originally anticipated that students in the intervention group would report lower levels of negative affect and higher levels of soothing positive affect compared to the control group following the intervention. However, we found significant differences between the two groups at post-test and at follow-up only for negative affect.

#### *The effectiveness of the intervention on secondary outcomes*

As expected, our results underscore the effectiveness of this intervention in addressing secondary outcomes, particularly those related to indicators of distress, such as depression, anxiety, and stress. However, the results for well-being markers, specifically activating positive affect and life satisfaction, seem less promising compared to the distress indicators.

At the outset of our study, we identified baseline differences in depression and stress levels, with psychology students reporting higher scores than their peers in other fields of study. Therefore, regarding depression and stress, mixed-model ANCOVA tests were performed, in order to control the baseline differences between the two groups (depression and stress measured at baseline were introduced in our models as covariates). As expected, regarding both, depression and stress levels, significant differences emerged between groups at the post-test and at the follow-up. Examining the effect of time on depression and stress independently within each group, multivariate tests revealed that the impact of time on depression and stress was present exclusively in the CMT group. Also, concerning anxiety, a significant time effect emerged solely within the CMT group, indicating a reduction in anxiety levels from baseline to post-test, which persisted through the follow-up assessment.

In terms of activating positive affect and life satisfaction, our analysis did not reveal any noteworthy effects related to time, group, or their interaction. Furthermore, group disparities and temporal variations were absent in these measures as well.

In light of these outcomes, it seems that the intervention's primary benefits lie in reducing distress levels, encompassing negative affect, depression, anxiety, and stress. Its impact on cultivating overall well-being, including soothing positive affect, activating positive affect, and life satisfaction, appears to be less pronounced. Furthermore, these results reinforce the significance of distinguishing between soothing and activating positive affect, based on Gilbert's theory (2009a, 2009b,

2014, Gilbert et al., 2008). Additionally, our findings align with prior research indicating that compassionate mind training mainly enhances soothing positive affect, with non-significant effects on activating positive affect (Matos et al., 2017).

#### *The effectiveness of the intervention on investigated mechanisms*

Anticipations included the intervention's effectiveness in fostering self-compassion and self-warmth, alongside a reduction in self-coldness and dysfunctional attitudes. Our findings support these expectations, as we identified significant differences between the two groups in self-compassion, self-warmth, self-coldness (after controlling for the baseline differences), and dysfunctional attitudes at the post-test, with the differences in self-warmth, self-coldness, and dysfunctional attitudes persisting through the follow-up.

Additionally, significant time effects solely within the CMT group, with no such effects seen in the control group. Within the control group, measures of self-compassion, self-warmth, self-coldness, and dysfunctional attitudes remained constant across all assessment time points. For participants within the CMT group, both self-compassion and self-warmth levels increased from baseline to post-test and remained stable through the follow-up assessment. The impact of time on self-coldness was also present exclusively in the CMT group. Comparatively, the CMT group exhibited a decline in dysfunctional attitudes from baseline to post-test, and these improvements remained steady during the follow-up period.

Taken together, these outcomes underscore the intervention's effectiveness in altering the mechanisms under investigation, successfully nurturing self-compassion and self-warmth, while concurrently mitigating self-coldness and dysfunctional attitudes.

#### *The longitudinal mediation role of the supposed mechanisms*

Prior research (Irons & Heriot-Maitland, 2021; Matos et al., 2022) has suggested that self-compassion serves as the primary mechanism of change within the CMT intervention. However, these studies have mainly relied on cross-sectional analyses, which may introduce bias due to an inability to account for the autoregressive nature of the data. Therefore, based on recommendations (Goldsmith et al., 2018; Maxwell et al., 2011) this study conducted longitudinal mediation analyses, examining the role of self-compassion on the clinical benefits of the intervention concerning primary outcomes, namely, negative and soothing positive affect.

Intriguingly, our findings diverge from prior expectations, revealing no longitudinal mediating effect for self-compassion. Building on Compassion-Focused Therapy's theoretical framework (Gilbert, 2009a, 2009b, 2014) and corroborative insights from meta-analyses (Chio et al., 2021; Muris and Petrocchi, 2016), which highlight the important distinction between self-warmth (positive dimensions of self-

compassion, compassionate behaviors) and self-coldness (negative dimensions of self-compassion, uncompassionate behaviors), we tested the individual mediation roles of self-warmth and self-coldness but found no significant longitudinal mediating effects. The longitudinal mediation analyses conducted in our study did not support self-compassion as a mechanism of change. However, it is worth noting that the small sample size may constrain our ability to detect such effects, potentially leading to false negative errors.

Furthermore, we undertook an exploratory assessment regarding the longitudinal mediating impact of dysfunctional attitudes on negative affect and soothing positive affect. The findings revealed no significant indirect effect on negative affect, yet a notable mediation effect emerged for post-test dysfunctional attitudes influencing follow-up soothing positive affect. These results imply that the intervention's elevation of soothing positive affect during follow-up is driven by the attenuation of dysfunctional attitudes measured at the post-test. This reinforces the crucial role dysfunctional attitudes play in students' overall well-being. In light of these findings, it appears that students may experience an enhanced sense of safety and contentment when their levels of typical dysfunctional beliefs (Weissman & Beck, 1978) are diminished.

#### *Limits and future directions*

Despite our encouraging results on the effectiveness of the CMT intervention in promoting students' well-being and reducing their distress, we must also consider a number of limitations of our study. A primary limitation revolves around the non-randomized allocation of participants to groups, resulting in significant disparities in baseline values across various measured variables. Consequently, it is imperative to advocate for further research, particularly randomized controlled trials, which represent the gold standard for effect assessment (David, 2012)

Another substantial limitation pertains to our study's modest sample size and the subsequent lack of statistical power, particularly when making inter-group comparisons at individual time points. The reliability of our results may also be influenced by the high attrition rate, primarily within the control group. To mitigate dropout rates and for other methodological reasons, future investigations should consider implementing active control groups to assess the effectiveness of Compassionate Mind Training on students' distress and well-being. An intriguing avenue for exploration could involve measuring and comparing the relative effectiveness of Compassionate Mind Training (Irons & Heriot-Maitland, 2021), based on Gilbert's (2009a, 2009b, 2014) theoretical framework and practices, against the Mindful-Self Compassion (MSC) program (Neff & Germer, 2012), which hinges on Neff's (2003a) conceptualization of self-compassion and its associated interventions.

Our study solely relied on self-reported measures to investigate the intervention's effectiveness. Nevertheless, future explorations should consider incorporating objective outcomes, such as Heart Rate Variability (HRV), as an indicator of intervention impact, in order to enhance robustness. Prior findings (Matos et al., 2017) have suggested that CMT can positively influence HRV, a physiological marker of well-being. Although it is also a subjective instrument, the validity of our research would be greatly enhanced if we used an Ecological Momentary Assessment (EMA) app such as the MoodWheel to measure emotional well-being and distress, which according to current results is an excellent tool for assessing students' emotions (Tomoioagă et al., 2024). Finally, our intervention group comprised solely Psychology students, warranting further assessments encompassing students from diverse majors to ensure more comprehensive and generalizable conclusions.

### Authors' Notes

**Acknowledgement.** This manuscript is original, has not been published before, and is not currently considered for publication elsewhere.

**Conflict of Interest.** No conflict of interest is associated with this publication, and there has been no financial support for this work that could have influenced its outcome.

**Publication Ethics.** The study was undertaken in accordance with the Code of Ethics of the American Psychological Association.

**Authorship.** All authors have substantial scientific contributions in organizing and conducting the analysis, in interpreting the results and findings, and all authors reviewed the manuscript and agreed on responsibility for its content.

### References

- Arpin-Cribbie, C., Irvine, J., & Ritvo, P. (2012). Web-based cognitive-behavioral therapy for perfectionism: a randomized controlled trial. *Psychother Res.*, 22(2), 194-207. <https://doi.org/10.1080/10503307.2011.637242>
- Beaumont, E., Bell, T., McAndrew, S., & Fairhurst, H. (2021). The impact of compassionate mind training on qualified health professionals undertaking a compassion-focused therapy module. *Counselling & Psychotherapy Research*, 21(4), 910-922. <https://doi.org/10.1002/capr.12396>
- Beaumont, E., & Martin, C. J. H. (2016). A proposal to support student therapists to develop compassion for self and others through Compassionate Mind Training. *The Arts in Psychotherapy*, 50, 111-118. <https://doi.org/10.1016/j.aip.2016.06.005>

- Beiter, R., Nash, R., McCrady, M., Rhoades, D., Linscomb, M., Clarahan, M., & Sammut, S. (2015). The prevalence and correlates of depression, anxiety, and stress in a sample of college students. *Journal of Affective Disorders, 173*, 90-96. <http://dx.doi.org/10.1016/j.jad.2014.10.054>
- Boellinghaus, I., Jones, F. W., & Hutton, J. (2013). Cultivating self-care and compassion in psychological therapists in training: The experience of practicing loving-kindness meditation. *Training and Education in Professional Psychology, 7*(4), 267–277. <https://doi.org/10.1037/a0033092>
- Bore, M., Pittolo, C., Kirby, D., Dluzewska, T., & Marlin, S. (2016). Predictors of psychological distress and well-being in a sample of Australian undergraduate students. *Higher Education Research & Development, 35*(5), 869-880. <https://doi.org/10.1080/07294360.2016.1138452>
- Chio, F.H.N., Mak, W.W.S., & Yu, B.C.L. (2021). Meta-analytic review on the differential effects of self-compassion components on well-being and psychological distress: The moderating role of dialecticism on self-compassion. *Clinical Psychology Review, 85*, 101986. <https://doi.org/10.1016/j.cpr.2021.101986>
- Cohen, J. (2013). *Statistical power analysis for the behavioral sciences*. Routledge.
- David, D. (2012). *Tratat de psihoterapiei cognitive și comportamentale*. Polirom.
- Diener, E., Emmons, R. A., Larsen, R. J., & Griffin, S. (1985). The satisfaction with life scale. *Journal of Personality Assessment, 49*(1), 71-75. [https://doi.org/10.1207/s15327752jpa4901\\_13](https://doi.org/10.1207/s15327752jpa4901_13)
- Dundas, I., Binder, P. E., Hansen, T. G. B., & Stige, S. H. (2017). Does a short self-compassion intervention for students increase healthy self-regulation? A randomized control trial. *Scandinavian Journal of Psychology, 58*(5), 443-450. <https://doi.org/10.1111/sjop.12385>
- Eriksson, T., Germundsjö, L., Åström, E., & Rönnlund, M. (2018). Mindful self-compassion training reduces stress and burnout symptoms among practicing psychologists: A randomized controlled trial of a brief web-based intervention. *Frontiers in Psychology, 9*, Article 2340. <https://doi.org/10.3389/fpsyg.2018.02340>
- Faul, F., Erdfelder, E., Lang, A., & Buchner, A. (2007). GPower 3: a flexible statistical power analysis program for the social, behavioral, and biomedical sciences. *Behavior Research Methods, 39*, 175–191. <https://doi.org/10.3758/BF03193146>
- Ferrari, M., Hunt, C., Harrysunker, A., Abbott, M. J., Beath, A. P., & Einstein, D. A. (2019). Self-compassion interventions and psychosocial outcomes: a meta-analysis of RCTs. *Mindfulness, 10*(8), 1455–1473. <https://doi.org/10.1007/s12671-019-01134-6>
- Finlay-Jones, A., Kane, R., & Rees, C. (2017). Self-compassion online: A pilot study of an internet-based self-compassion cultivation program for psychology trainees. *Journal of Clinical Psychology, 73*(7), 797-816. <https://doi.org/10.1002/jclp.22375>

- Gerber, Z., & Anaki, D. (2021). The role of self-compassion, concern for others, and basic psychological needs in the reduction of caregiving burnout. *Mindfulness*, 12, 741-750. <https://doi.org/10.1007/s12671-020-01540-1>
- Germer, C.K. (2009). *The mindful path to self-compassion. Freeing yourself from destructive thoughts and emotions*. The Guilford Press.
- Gilbert, P. (2009a). Introducing compassion-focused therapy. *Advances in psychiatric treatment*, 15(3), 199-208. <https://doi.org/10.1192/apt.bp.107.005264>
- Gilbert, P. (2009b). *The compassionate mind*. Constable & Robinson Ltd.
- Gilbert, P. (2014). The origins and nature of compassion focused therapy. *British Journal of Clinical Psychology*, 53(1), 6-41. <https://doi.org/10.1111/bjc.12043>
- Gilbert, P., McEwan, K., Mitra, R., Franks, L., Richter, A., & Rockliff, H. (2008). Feeling safe and content: A specific affect regulation system? Relationship to depression, anxiety, stress, and self-criticism. *The Journal of Positive Psychology*, 3(3), 182–191. <https://doi.org/10.1080/17439760801999461>
- Gilbert, P., & Procter, S. (2006). Compassionate Mind Training for People with high shame and self-criticism: overview and pilot study of a group therapy approach. *Clinical Psychology & Psychotherapy*, 13(6), 353–379. <https://doi.org/10.1002/cpp.507>
- Goldsmith, K. A., MacKinnon, D. P., Chalder, T., White, P. D., Sharpe, M., & Pickles, A. (2018). Tutorial: The practical application of longitudinal structural equation mediation models in clinical trials. *Psychological Methods*, 23(2), 191–207. <https://doi.org/10.1037/met0000154>
- Hayes, A. F. (2018). *Introduction to mediation, moderation, and conditional process analysis: A regression-based approach*. Guilford Press.
- Irons, C., & Beaumont, E. (2017). *The compassionate mind workbook. A step-by-step guide to developing your compassionate self*. Robinson.
- Irons, C., & Heriot-Maitland, C. (2021). Compassionate mind training: An 8-week group for the general public. *Psychology and Psychotherapy: Theory, Research and Practice*, 94(3), 443- 463. <https://doi.org/10.1111/papt.12320>
- Kopp, M. (1985). *Klinikai pszichofiziológia. Pszichoszomatikus füzetek 2*. MAOTE & MPT.
- Larcombe, W., Finch, S., Sore, R., Murray, C.M., Kentish, S., Mulder, R.A., Lee-Stecum, P., Baik, C., Tokatlidis, O., & Williams, D.A. (2016). Prevalence and socio-demographic correlates of psychological distress among students at an Australian university. *Studies in Higher Education*, 41(6), 1074-1091. <https://doi.org/10.1080/03075079.2014.966072>
- Leary, M. R., Tate, E. B., Adams, C. E., Batts Allen, A., & Hancock, J. (2007). Self-compassion and reactions to unpleasant self-relevant events: The implications of treating oneself kindly. *Journal of Personality and Social Psychology*, 92(5), 887-904. <https://doi.org/10.1037/0022-3514.92.5.887>
- Loudon, K., Treweek, S., Sullivan, F., Thorpe, K. E., & Zwarenstein, M. (2015). The PRECIS-2 tool: designing trials that are fit for purpose. *BMJ*, 350, h2147. <https://doi.org/10.1136/bmj.h2147>

- Lovibond, S.H., & Lovibond, P.F. (1995). *Manual for the Depression Anxiety Stress Scales. (2nd. Ed.)*. Psychology Foundation.
- Mantelou, A., & Karakasidou, E. (2017). The effectiveness of a brief self-compassion intervention program on self-compassion, positive and negative affect and life satisfaction. *Psychology, 8*(4), 59-610. <https://doi.org/10.4236/psych.2017.84038>
- Martos, T., Sallay, V., Desfalvi, J., Szabó, T., & Ittész, A. (2014). Az Élettel Való Elégedettség Skála Magyar változatának (SWLS-H) pszichometriai jellemzői. *Mentálhigiéne és Pszichoszomatika, 15*(3), 289-303. <http://dx.doi.org/10.1556/Mental.15.2014.3.9>
- Matos, M., Duarte, C., Duarte, J., Pinto-Gouveia, J., Petrocchi, N., Basran, J., & Gilbert, P. (2017). Psychological and physiological effects of compassionate mind training: A pilot randomized controlled study. *Mindfulness, 8* (6), 1699–1712. <https://doi.org/10.1007/s12671-017-0745-7>
- Matos, M., Duarte, C., Duarte, J., Pinto-Gouveia, J., Petrocchi, N., & Gilbert, P. (2022). Cultivating the compassionate self: An exploration of the mechanisms of change in compassionate mind training. *Mindfulness, 13*(1), 66–79. <https://doi.org/10.1007/s12671-021-01717-2>
- Maxwell, S. E., Cole, D. A., & Mitchell, M. A. (2011). Bias in cross-sectional analyses of longitudinal mediation: partial and complete mediation under an autoregressive model. *Multivariate Behav Res., 46*(5), 816-841. <https://doi.org/10.1080/00273171.2011.606716>
- McIntyre, R., Smith, P., & Rimes, K. A. (2018). The role of self-criticism in common mental health difficulties in students: A systematic review of prospective studies. *Mental Health & Prevention, 10*, 13-27. <https://doi.org/10.1016/j.mhp.2018.02.003>
- Muris, P., & Petrocchi, N. (2016). Protection or vulnerability? A meta-analysis of the relations between the positive and negative components of self-compassion and psychopathology. *Clinical Psychology and Psychotherapy, 24*(2), 373-383. <https://doi.org/10.1002/cpp.2005>
- Neff, K. (2003a). Self-compassion: An alternative conceptualization of a healthy attitude toward oneself. *Self and Identity, 2*(2), 85-101. <https://psycnet.apa.org/doi/10.1080/15298860309032>
- Neff, K. (2003b). The development and validation of a scale to measure self-compassion. *Self and Identity, 2*(3), 223–250. <https://psycnet.apa.org/doi/10.1080/15298860309027>
- Neff, K.D., & Germer, C. K. (2012). A pilot study and randomized controlled trial of the Mindful Self- Compassion Program. *Journal of Clinical Psychology, 69*(1), 28-44. <https://doi.org/10.1002/jclp.21923>
- Oprış, D., & Macavei, B. (2005). The distinction between functional and dysfunctional negative emotions: An empirical analysis. *Journal of Cognitive and Behavioral Psychotherapies, 5*(2), 181–195.
- Póka, T., Fodor, L.-A., Barta, A., & Mérő, L. (2023). A systematic review and meta-analysis on the effectiveness of self-compassion interventions for changing

- university students' positive and negative affect. *Current Psychology*, <http://dx.doi.org/10.1007/s12144-023-04834-4>
- Preacher, K. J., & Hayes, A. F. (2004). SPSS and SAS procedures for estimating indirect effects in simple mediation models. *Behavior Research Methods, Instruments, & Computers*, *36*(4), 717- 731. <https://doi.org/10.3758/bf03206553>
- Raes, F., Pommier, E., Neff, K. D., & Van Gucht, D. (2011). Construction and factorial validation of a short form of the Self-Compassion Scale. *Clin Psychol Psychother*, *18*(3), 250-255. <https://doi.org/10.1002/cpp.702>
- Regehr, C., Glancy, D., & Pitts, A. (2013). Interventions to reduce stress in university students: A review and meta-analysis. *Journal of Affective Disorders*, *148*(1), 1–11. <https://doi.org/10.1016/j.jad.2012.11.026>
- Shapira, L.B., & Mongrain, M. (2010). The benefits of self-compassion and optimism exercises for individuals vulnerable to depression. *The Journal of Positive Psychology*, *5*(5), 377-389. <http://dx.doi.org/10.1080/17439760.2010.516763>
- Tabachnick, B. G., & Fidell, L. S. (2013). *Using Multivariate Statistics (6th ed.)*. Pearson.
- Tomoiağă, C., Gheorghiu, R., & David, O. A. (2024). Usability of an ecological momentary assesment app for mood evaluation in young adults – The MoodWheel App. *Journal of Evidence-Based Psychotherapies*, *24*(1), 135-143. DOI: 10.24193/jebp.2024.1.8
- Turk, F., & Waller, G. (2020). Is self-compassion relevant to the pathology and treatment of eating and body image concerns? A systematic review and meta-analysis. *Clinical Psychology Review*, *79*, <https://doi.org/10.1016/j.cpr.2020.101856>
- Yela, J. R., Gómez-Martinez, Á., Crego, A., & Jiménez, L. (2020). Effects of the Mindful Self- Compassion programme on clinical and health psychology trainees' well-being: A pilot study, *Clinical Psychologist*, *24*(1), 41-54. <https://doi.org/10.1111/cp.12204>
- Wakelin, K. E., Perman, G. & Simonds, L.M. (2022). Effectiveness of self-compassion-related interventions for reducing self-criticism: A systematic review and meta-analysis. *Clinical Psychology & Psychotherapy*, *29*(1), 1-25. <https://doi.org/10.1002/cpp.2586>
- Weissman, A. N., & Beck, A. T. (1978). *Development and validation of the Dysfunctional Attitude Scale: A preliminary investigation*. <https://eric.ed.gov/?id=ED167619>
- Zessin, U., Dickhauser, O., & Garbade, S. (2015). The relationship between self-compassion and well- being: A meta-analysis. *Applier Psychology: Health and Well-Being*, *7*(3), 340-364. <https://doi.org/10.1111/aphw.12051>



---

## IMPAIRED EMOTIONAL PROCESSING IN MAJOR DEPRESSIVE DISORDER. ACCURACY VERSUS PROCESSING SPEED

---

*Bogdan Nemeş<sup>1\*</sup>, Horia G. Coman<sup>2</sup>, Dana C. Herța<sup>3</sup>,  
Raluca N. Trifu<sup>4</sup>, and Doina M. C. Cozman<sup>5</sup>*

<sup>1</sup> Department of Medical Psychology and Psychiatry, Iuliu Hațieganu University of Medicine and Pharmacy Cluj-Napoca. ORCID ID: <https://orcid.org/0000-0002-1381-798X>

<sup>2</sup> Department of Medical Psychology and Psychiatry, Iuliu Hațieganu University of Medicine and Pharmacy Cluj-Napoca; 3rd Psychiatry Department, Cluj County Emergency Clinical Hospital. ORCID ID: <https://orcid.org/0000-0001-8734-2852>

<sup>3</sup> Department of Medical Psychology and Psychiatry, Iuliu Hațieganu University of Medicine and Pharmacy Cluj-Napoca. ORCID ID: <https://orcid.org/0000-0003-1437-3361>

<sup>4</sup> Department of Medical Psychology and Psychiatry, Iuliu Hațieganu University of Medicine and Pharmacy Cluj-Napoca. ORCID ID: <https://orcid.org/0000-0002-9883-3697>

<sup>5</sup> Department of Medical Psychology and Psychiatry, Iuliu Hațieganu University of Medicine and Pharmacy Cluj-Napoca. ORCID ID: <https://orcid.org/0000-0001-7102-2432>

---

### Abstract

Depression is one of the most frequent conditions within the general population, ranking among the most burdensome in terms of public health expenses, productivity loss and social costs. The condition has been linked with cognitive deficits that may even continue in remission phases, social cognition being one potentially affected cognitive function. In our study, the Penn's Emotional Acuity Test included in the Cogtest™ battery was used to assess emotion recognition accuracy and processing speed. The Structured Clinical Interview for the Montgomery-Asberg Depression Rating Scale was used to assess the intensity of the symptomatology. A total of 48 depressed individual individuals (65% females), with a mean age of  $49.8 \pm 10.4$  years, and 40 healthy controls (75% females), with a mean age of  $35.2 \pm 6.9$  years were included. As compared to controls, depressive participants recorded significantly less correct answers ( $9.3 \pm 3.8$  vs.  $11.2 \pm 3.6$ ,  $p = 0.019$  – Student's t test) and slower processing speeds ( $6795 \pm 3366$  vs.  $4042 \pm 1623$ ,  $p < 0.001$  – Mann-Whitney U test) in emotion processing. Furthermore, symptom severity significantly influences only processing speed and not accuracy in emotion recognition tasks. Thus, we conclude that depressive

---

\* Correspondence concerning this article should be addressed to Bogdan Nemeş, Medical Psychology and Psychiatry Department, Iuliu Hațieganu University of Medicine and Pharmacy Cluj-Napoca, 43rd Victor Babeş St., 400012 Cluj-Napoca, Romania.  
E-mail: [nemes.bogdan@umfcluj.ro](mailto:nemes.bogdan@umfcluj.ro)

individuals have a significant deficit in processing speed and accuracy when identifying the intensity of other peoples' emotions.

**Keywords:** major depressive disorder, emotional processing, social cognition.

Depression is one of the most frequent conditions within the general population, with up to 20% of all individuals going through a depressive episode at some point during their lives (Kessler & Wang, 2009; Hasin et al., 2018). It is also one of the most debilitating diseases (Murray & Lopez, 1996) in terms of public health costs (WHO, 2001; Zhdanova et al., 2021), loss of productivity (Kessler et al., 2006) and social costs (Gotlib & Joorman, 2010). The loss in productivity and high social costs have been linked to cognitive symptoms in this disorder, as they significantly impact both occupational and social functioning (McIntyre et al., 2013).

Specifically, numerous studies have proven that depressed individuals show important deficits in various domains of cognitive functioning such as, but not limited to: working memory, verbal and visual memory, verbal fluency, attentional set-shifting, motor speed, inhibitory control etc., and that these deficits may continue after the remission of the depressive episode, impairing full functional recovery (McIntyre et al., 2013; Hasselbalch et al., 2011; Marazziti et al., 2010; Jaeger et al., 2006; Tabur et al., 2024). Other cognitive dimensions of depression such as social cognition have been less well documented, although they have long been considered at the core of depressive symptoms and thought to play a crucial role in successful interpersonal and day-to-day functioning (Weightman et al., 2014; Baune & Air, 2016).

Social cognition refers to the mental processes underlying social interactions (Horan et al., 2011) encompassing identification, perception and interpretation of social cues (Kandalaf et al., 2012), and generating responses to the intentions, emotions and behaviors of others (Kunda, 1999; Fiske & Taylor, 1991). Thus, previous research on social cognition in major depressive disorder has focused primarily on the ability of depressed individuals to correctly perceive facial expressions of emotion (i.e. facial expression recognition) or their ability to attribute feelings, beliefs, intentions and desires to others (i.e. theory of mind) (Weightman et al., 2014). In this sense, a recent meta-analysis has suggested that depressive patients show a general, low-strength, emotion recognition deficit (Dalili et al., 2015). However, the authors also concluded that more research is needed to investigate the accuracy of emotion recognition in major depressive disorder patients and the relationship of this impairment with the severity of depressive symptoms (Dalili et al., 2015), since the currently available data is scarce.

In line with these findings, the aim of this study was to investigate the accuracy and processing speed of emotion recognition in major depressive disorder patients and its relationship with the severity of depressive symptomatology.

## Method

### *Participants*

Patients being treated for depression in the 3rd Psychiatry Clinic of the Cluj County Emergency University Hospital were asked to participate in the study. After being provided with detailed information about study procedures and being offered adequate time to make an informed decision, patients that agreed to participate in the study were asked to sign a study-specific Informed Consent Form. Two consultant psychiatrists confirmed the diagnosis independently, based on the criteria defined by WHO (1992) in the International Classification of Diseases and Related Health Problems 10th Revision (ICD-10). The inclusion criteria also required participants to be of adult age (i.e. 18 years old or more), were required to have completed at least 8 years of formal education, be fluent in Romanian and possess the ability to read and understand the informed consent.

Healthy individuals were asked to participate in the study in order to establish the control group. Healthy controls were recruited via public advertisement and underwent the same inclusion procedure as the depressed individuals. After obtaining informed consent, psychiatric disorders were excluded independently by two consultant psychiatrists, using the ICD-10 criteria (WHO, 1992).

Participants with somatic disorders capable of significantly influencing the results of the neuropsychological testing were excluded (i.e. movement disorders, significantly impaired visual acuity, acute infectious disease, etc.). Patients with comorbid psychiatric disorders were also excluded from the study.

After revising the inclusion and exclusion criteria, participants underwent clinical and neuropsychological testing to assess for the severity of depression and cognitive impairment, respectively.

The study protocol was designed in accordance with all national and international regulations, including the guidelines of the World Health Organization (WHO) and the Declaration of Helsinki, and was approved by the Ethics Commission of the Iuliu Hațieganu University of Medicine and Pharmacy Cluj-Napoca.

### *Measures*

The Penn's Emotional Acuity Test (PEAT) included in the Cogtest™ computerized battery was used to assess for emotion recognition accuracy (Erwin et al., 1992; Rojahn et al., 2000). In short, participants were presented with 40 human faces displaying emotional expressions varying from very happy to very sad. No time limit was given for the assessment of the images by participants. The participants were asked to rate the respective faces on a 7-point Likert scale: *very*

*happy* (7), *moderately happy* (6), *slightly happy* (5), *neutral* (4), *slightly sad* (3), *moderately sad* (2) and *very sad* (1). The number of exact answers (e.g. classifying a moderately happy face as slightly happy or any other answer was considered incorrect) and the processing speed (i.e. time taken to answer) were automatically recorded for each participant.

The intensity of the depressive symptomatology was assessed using the Structured Clinical Interview for the Montgomery-Asberg Depression Rating Scale (MADRS) (Montgomery & Asberg, 1979; Williams & Kobak, 2008). This assessment was conducted on the same day with the neuropsychological evaluation by an experienced and certified rater.

### *Statistical analysis*

Means and standard deviations are given to describe scale data distributions in each group. The  $\chi^2$  test was used to assess for differences in the distribution of categorical data, with Fisher's Exact test where necessary. The Kolmogorov-Smirnov test was used to assess whether data was normally distributed. Furthermore, the skewness and kurtosis and their respective standard errors were calculated. Whenever the data was normally distributed or when the data was not normally distributed but the ratio between skewness / standard error of skewness and the ratio between kurtosis / standard error of kurtosis for each group were situated between -2 and 2, the Student's t test was used to test for differences between groups, with the Levine statistic used to assess for the differences of variances. Conversely, when the data was not normally distributed and the ratios between skewness / standard error of skewness and that between kurtosis / standard error of kurtosis were outside of the [-2,2] interval, the Mann-Whitney U test was used to test for between-group differences. Pearson and Spearman correlation coefficients were used to evaluate associations between quantitative variables. Linear, multivariate regression models were built to investigate the relationship between emotional processing accuracy and speed, on one hand, and sex, age and severity of depressive symptomatology on the other hand. The statistical analysis was performed using the Statistical Pack for Social Sciences – SPSS, version 22.

## **Results**

A total of 48 individuals with a diagnosis of depression, and 40 healthy controls were included in the study, based on the above-mentioned inclusion and exclusion criteria. The main demographic characteristics of the participants are detailed in Table 1. While the difference in sex and education level distributions across the two groups were not statistically significant, depressive participants were significantly older than controls. All subsequent statistical analyses were therefore

controlled for age. None of the participants underwent any form of psychological treatments or psychosocial programs and were compliant to the pharmacological treatment prescribed as per current protocols.

**Table 1.** Demographic characteristics of the participants

	Clinical group N = 48	Control group N = 40	<i>p</i>
Sex (% - females)	64.58	75.00 %	NS <sup>1</sup>
Age (years)*	49.8 ± 10.4	35.2 ± 6.9	< 0.002 <sup>2</sup>
Education (years)	13.0 (10; 14)	14 (10; 15)	NS <sup>1</sup>

M ± SD – mean ± standard deviation; NS – not significant at the 0.05 level; <sup>1</sup>  $\chi^2$  test; <sup>2</sup> - Mann-Whitney U test; \* the skewness of age for the clinical group was -1,220 with a standard error of 0,343, and the kurtosis was 1,005 with a standard error of 0,674, while the skewness for the control group was 0.227 with a standard error of 0.383, and the kurtosis was -0.387 with a standard error of 0.750.

As compared to controls, depressive participants recorded significantly less correct answers and slower processing speed in emotion processing (Table 2).

**Table 2.** Intergroup differences in emotional processing performance and depressive symptomatology

	Depressive participants			Controls			<i>p</i>
	Mean (SD)	Skewness (SE)	Kurtosis (SE)	Mean (SD)	Skewness (SE)	Kurtosis (SE)	
No. of correct answers	9.3 (3.8)	0.586 (0.343)	0.327 (0.674)	11.2 (3.6)	-0.014 (0.374)	-0.052 (0.733)	0.019 <sup>1</sup>
Processing speed (ms)	6795 (3366)	2.188 (0.343)	5.717 (0.674)	4042 (1623)	2.408 (0.374)	6.578 (0.733)	< 0.001 <sup>2</sup>
MADRS total score	30.2 (8.5)	-0.225 (0.343)	-0.333 (0.674)	2.2 (2.8)	1.517 (0.374)	1.940 (0.733)	< 0.001 <sup>2</sup>

<sup>1</sup> Student's *t* Test; <sup>2</sup> Mann-Whitney U Test;

Both emotional processing accuracy and processing speed significantly correlated with age, severity of depressive symptomatology and each other. Zero order correlation coefficients are presented in Table 3.

**Table 3.** Zero order correlations (Spearman's rho) between emotional processing parameters and demographic/clinical parameters

	Age	MADRS total score	No. of correct answers	Processing speed
Age (years)	1	0.456**	-0.264*	0.586**
MADRS total score	0.456**	1	-0.227*	0.568**
No. of correct answers	-0.264*	-0.227*	1	-0.399**
Processing speed (ms)	0.586**	0.568**	-0.399**	1

\*  $p < 0.05$ ; \*\*  $p < 0.01$

Regression models revealed that the only variable that significantly influences the number of correct answers is processing speed ( $Std(B) = -0,400, p < 0,001 - Std(B), Adj. R^2 = 0,192, p < 0,001 - ANOVA$ ), with all other variables being ruled out as not significant.

When using processing speed as a dependent variable in hierarchical regression models, the best fit is reached with age and MADRS total scores as independent variables (Table 4).

**Table 4.** Best-fit model for emotional processing speed

Independent variables	<i>Std(B)</i>	<i>p - Std(B)</i>	<i>Adj. R<sup>2</sup></i>	<i>p - ANOVA</i>
Age (years)	0,347	0.001	0.377	< 0.001
MADRS total score	0.367	0.001		

## Discussion

Our findings indicate that depression is associated with a significant impairment in emotional processing, both in terms of accuracy and in terms of processing speed. Furthermore, our results show that the severity of depressive symptomatology is correlated with processing speed, but not accuracy, in emotional processing tasks.

The fact that depressive patients show a significant deficit in correctly identifying facial expressions of emotions has been relatively well-established in the past (Bourke et al., 2010) by using various paradigms and stimulus sets, but most of these studies used full intensity facial expressions (Gotlib & Joorman, 2010) of the six basic emotions (Ekman & Friesen, 1971). In real life, however, people are confronted with various intensities of facial expressions of emotion (mostly with low to moderate intensities), and correct identification of both the emotion and its intensity is necessary for the coherent adaptation of one's behavior to the emotions of others. Regarding the correct identification of specific emotions, currently available data indicates that depressive patients show deficits in correctly identifying anger, disgust, fear, happiness, and surprise, but not sadness (Dalili et al., 2015). On the other hand, the very few studies conducted so far using subtle facial expressions of emotions support the hypothesis that depressive patients show difficulties in identifying subtle expressions of happiness, but not sadness (Joormann & Gotlib, 2006). Building on these results, we have evaluated the accuracy with which depressive patients classify the intensity of emotions on a continuum from sadness

to happiness and found that depressive patients are less accurate in classifying the intensity of emotions based on their facial expressions.

Depressive patients showed significantly slower processing speeds than controls. This is attributable to psychomotor retardation, a core symptom of depression (WHO, 1992; APA, 2013), and in line with previous findings showing that depressive patients exhibit slower processing speeds or slower reaction times virtually irrespective of the tested cognitive domain (McIntyre et al., 2013). Nevertheless, our study is one of the few that addressed the speed of emotional processing bringing evidence that this cognitive subdomain is also impaired in depressed patients.

Some evidence exists to support the hypothesis that symptom severity positively correlates with emotional processing impairment, but it is not sufficient to draw definite conclusions (Dalili et al., 2015). Adding to current evidence, our results show that symptom severity (as assessed by the MADRS) is associated with processing speed, but not emotional processing accuracy. These findings are in line with previous research pointing to an association between emotional processing impairment and self-reported depressive symptoms, as assessed by the Beck Depression Inventory – BDI, but not with clinician-based measures of depressive symptoms, as is the case of the Hamilton Rating Scale for Depression (HAM-D) for example (Kohler et al., 2011). Several hypotheses have been formulated to explain this discrepancy thus far, including the possibility that the BDI studies used samples with higher clinical acuity or that self-identified depression and social cognition are somehow related, but none of these theories are backed up by sufficient evidence (Kohler et al., 2011). Another explanation could be that the accuracy of emotional perception is a trait of depressed individuals and therefore not linked to depressive symptomatology. This latter explanation would be in line with previous findings reporting persistence of emotional processing deficits after the remission of illness (Leppanen et al., 2004). However, this remains a topic that needs to be addressed in future research.

Our results also point to the conclusion that age is negatively correlated with processing speed and not significantly associated with the accuracy of emotional processing. These results are opposed to previous findings, which found a positive association between age and emotional processing (Elfenbein & Ambady, 2002; Johnson & Fredrickson, 2005; Merten, 2005), and speculated that greater life experience with emotions might help older patients in their ability to correctly identify facial expressions of emotions (Kohler et al., 2011). One possible explanation for this discrepancy could be that, in our sample, age positively correlated with symptom severity, just as emotional processing parameters did. In fact, the use of various samples, paradigms and stimulus sets has made it very difficult to compare results across studies so far (Dalili et al., 2015). It is therefore

arguable that a consensus for evaluating cognitive deficits in depression needs to be reached, similar to the ones used in schizophrenia, e.g. NIMH-MATRICES Consensus Cognitive Battery (Green et al., 2004).

Furthermore, in line with previous findings (Kohler et al., 2011), we have found no significant association between sex and emotional processing, although a minor association was proven in general population-based studies pointing to better emotion perception abilities in women (Merten, 2005).

Several limitations of our study need to be pointed out. First, we have a rather small sample size, although more than double the median sample size of the studies included in the latest available meta-analysis on the subject (Dalili et al., 2015). Therefore, our results need to be replicated by further studies before accepting these conclusions beyond reasonable doubt. Also, the patients included in the clinical sample were under treatment with antidepressants, mood stabilizers and antipsychotics. The treatment plans of the patients were very complex and heterogeneous. Thus, including medication as a confounder in the present analysis was not possible. However, none of the patients included had sedation as a side effect of their treatment plan. Nevertheless, a further analysis on how specific medications influence patients' ability to accurately identify emotions would be of interest, since some of these medications can influence cognitive functioning. Furthermore, we have not extracted data on negative bias of emotional processing, i.e. the presumable tendency of depressive patients to classify ambiguous faces as happy vs. sad, although currently available data on this topic shows that more research is needed on the matter (Leppanen et al., 2004; Dalili et al., 2015). This remains to be investigated in further research.

### *Conclusion*

The present study brings evidence that depressive individuals have a significant deficit in accurately identifying the intensity of other peoples' emotions, as assessed on a sadness-happiness continuum, and are significantly slower in processing such information than controls. Furthermore, we have shown that symptom severity significantly influences only processing speed and not accuracy in emotion recognition tasks.

### **Authors' Notes**

The first two authors had the same contribution to this manuscript.

**Declaration of interest.** We have no known conflict of interest to disclose.

**Acknowledgements.** This paper was published under the frame of the European Social Fund, Human Resources Development Operational Programme 2007-2013, project no. POSDRU/159/1.5/S/138776.

## References

- American Psychiatric Association. (2013). *Diagnostic and statistical manual of mental disorders* (5th ed.).
- Baune, B. T., & Air, T. (2016). Clinical, Functional, and Biological Correlates of Cognitive Dimensions in Major Depressive Disorder – Rationale, Design, and Characteristics of the Cognitive Function and Mood Study (CoFaM-Study). *Frontiers in Psychiatry*, 7. <https://doi.org/10.3389/fpsy.2016.00150>
- Bourke, C., Douglas, K. M., & Bryant, R. A. (2010). Processing of Facial Emotion Expression in Major Depression: A Review. *Australian and New Zealand Journal of Psychiatry*, 44(8), 681–696. <https://doi.org/10.3109/00048674.2010.496359>
- Dalili, M. N., Penton-Voak, I. S., Harmer, C. J., & Munafò, M. R. (2015). Meta-analysis of emotion recognition deficits in major depressive disorder. *Psychological Medicine*, 45(6), 1135–1144. <https://doi.org/10.1017/s0033291714002591>
- Ekman, P., & Friesen, W. V. (1971). Constants across cultures in the face and emotion. *Journal of Personality and Social Psychology*, 17(2), 124–129. <https://doi.org/10.1037/h0030377>
- Elfenbein, H. A., & Ambady, N. (2002). On the universality and cultural specificity of emotion recognition: A meta-analysis. *Psychological Bulletin*, 128(2), 203–235. <https://doi.org/10.1037/0033-2909.128.2.203>
- Erwin, R. J., Gur, R. C., Gur, R. E., Skolnick, B. E., Mawhinney-Hee, M., & Smailis, J. (1992). Facial emotion discrimination: I. Task construction and behavioral findings in normal subjects. *Psychiatry Research-Neuroimaging*, 42(3), 231–240. [https://doi.org/10.1016/0165-1781\(92\)90115-j](https://doi.org/10.1016/0165-1781(92)90115-j)
- Fiske, S. T., & Taylor, S. E. (1991). *Social Cognition*. McGraw-Hill Humanities, Social Sciences & World Languages.
- Gotlib, I. H., & Joormann, J. (2010). Cognition and Depression: Current Status and Future Directions. *Annual Review of Clinical Psychology*, 6(1), 285–312. <https://doi.org/10.1146/annurev.clinpsy.121208.131305>
- Green, M. F., Nuechterlein, K. H., Gold, J. M., Deanna, M., Cohen, J. D., Essock, S. M., Fenton, W. A., Frese, F., Goldberg, T. E., Heaton, R. K., Keefe, R. S., Kern, R. C., Kraemer, H. C., Stover, E., Weinberger, D. R., Zalcman, S. S., & Marder, S. R. (2004). Approaching a consensus cognitive battery for clinical trials in schizophrenia: The NIMH-MATRICES conference to select cognitive

- domains and test criteria. *Biological Psychiatry*, 56(5), 301–307. <https://doi.org/10.1016/j.biopsych.2004.06.023>
- Hasin, D. S., Sarvet, A. L., Meyers, J. L., Saha, T. D., Ruan, W. J., Stohl, M., & Grant, B. F. (2018). Epidemiology of Adult DSM-5 Major Depressive Disorder and Its Specifiers in the United States. *JAMA Psychiatry*, 75(4), 336–346. <https://doi.org/10.1001/jamapsychiatry.2017.4602>
- Hasselbalch, B. J., Knorr, U., & Kessing, L. V. (2011). Cognitive impairment in the remitted state of unipolar depressive disorder: A systematic review. *Journal of Affective Disorders*, 134(1–3), 20–31. <https://doi.org/10.1016/j.jad.2010.11.011>
- Horan, W. P., Harvey, P. O., Kern, & Green. (2011). Neurocognition, social cognition and functional outcome in schizophrenia. In W. Gaebel (Ed.), *Schizophrenia Current Science and Clinical Practice* (pp. 74–80). John Wiley & Sons.
- Jaeger, J., Berns, S., Uzelac, S. M., & Davis-Conway, S. (2006). Neurocognitive deficits and disability in major depressive disorder. *Psychiatry Research-Neuroimaging*, 145(1), 39–48. <https://doi.org/10.1016/j.psychres.2005.11.011>
- Johnson, K. J., & Fredrickson, B. L. (2005). “We All Look the Same to Me.” *Psychological Science*, 16(11), 875–881. <https://doi.org/10.1111/j.1467-9280.2005.01631.x>
- Joormann, J., & Gotlib, I. H. (2006). Is this happiness I see? Biases in the identification of emotional facial expressions in depression and social phobia. *Journal of Abnormal Psychology*, 115(4), 705–714. <https://doi.org/10.1037/0021-843x.115.4.705>
- Kandalajt, M. R., Didehbani, N., Cullum, C. M., Krawczyk, D. C., Allen, T. T., Tamminga, C. A., & Chapman, S. C. (2012). The Wechsler ACS Social Perception Subtest. *Journal of Psychoeducational Assessment*, 30(5), 455–465. <https://doi.org/10.1177/0734282912436411>
- Kessler, R. C., & Wang, P. S. (2009). Epidemiology of depression. In I. H. Gotlib & C. L. Hammen (Eds.), *Handbook of depression* (pp. 5–22). The Guilford Press.
- Kessler, R. C., Akiskal, H. S., Ames, M., Birnbaum, H. G., Greenberg, P. B., Hirschfeld, R., Jin, R., Merikangas, K. R., Simon, G. E., & Wang, P. S. (2006). Prevalence and Effects of Mood Disorders on Work Performance in a Nationally Representative Sample of U.S. Workers. *American Journal of Psychiatry*, 163(9), 1561–1568. <https://doi.org/10.1176/ajp.2006.163.9.1561>
- Kohler, C. G., Hoffman, L. A., Eastman, L., Healey, K. M., & Moberg, P. J. (2011). Facial emotion perception in depression and bipolar disorder: A quantitative review. *Psychiatry Research-Neuroimaging*, 188(3), 303–309. <https://doi.org/10.1016/j.psychres.2011.04.019>
- Kunda, Z. (1999). *Social Cognition: Making Sense of People*. MIT Press.
- Marazziti, D., Consoli, G., Picchetti, M., Carlini, M., & Faravelli, L. (2010). Cognitive impairment in major depression. *European Journal of Pharmacology*, 626(1), 83–86. <https://doi.org/10.1016/j.ejphar.2009.08.046>

- McIntyre, R. S., Cha, D. S., Soczynska, J. K., Woldeyohannes, H. O., Gallagher, L. A., Kudlow, P., Alsuwaidan, M., & Baskaran, A. (2013). Cognitive deficits and functional outcomes in major depressive disorder: Determinants, substrates, and treatment interventions. *Depression and Anxiety, 30*(6), 515–527. <https://doi.org/10.1002/da.22063>
- Merten, J. (2005). Culture, gender and the recognition of the basic emotions. *Psychologia, 48*(4), 306–316. <https://doi.org/10.2117/psychoc.2005.306>
- Montgomery, S., & Åsberg, M. (1979). A New Depression Scale Designed to be Sensitive to Change. *British Journal of Psychiatry, 134*(4), 382–389. <https://doi.org/10.1192/bjp.134.4.382>
- Murray, C. J. L., & Lopez, A. D. (1996). Evidence-Based Health Policy—Lessons from the Global Burden of Disease Study. *Science, 274*(5288), 740–743. <https://doi.org/10.1126/science.274.5288.740>
- Puura, K., Milders, M., Bell, J. S., Terrière, E., & Hietanen, J. K. (2004). Depression biases the recognition of emotionally neutral faces. *Psychiatry Research-Neuroimaging, 128*(2), 123–133. <https://doi.org/10.1016/j.psychres.2004.05.020>
- Rojahn, J., Gerhards, F., Matlock, S. T., & Kroeger, T. L. (2000). Reliability and validity studies of the Facial Discrimination Task for emotion research. *Psychiatry Research-Neuroimaging, 95*(2), 169–181. [https://doi.org/10.1016/s0165-1781\(00\)00169-4](https://doi.org/10.1016/s0165-1781(00)00169-4)
- Tabur, S. T., Akın, E., & Turkcapar, M. H. (2024). Personality Traits, Preoperational Thinking, and Mental Health. *Journal of Evidence-Based Psychotherapies, 24*(1), 117-134.
- Weightman, M., Air, T., & Baune, B. T. (2014). A Review of the Role of Social Cognition in Major Depressive Disorder. *Frontiers in Psychiatry, 5*. <https://doi.org/10.3389/fpsy.2014.00179>
- Williams, J. B. W., & Kobak, K. A. (2008). Development and reliability of a structured interview guide for the Montgomery-Åsberg Depression Rating Scale (SIGMA). *British Journal of Psychiatry, 192*(1), 52–58. <https://doi.org/10.1192/bjp.bp.106.032532>
- World Health Organization. (1992). *The ICD-10 classification of mental and behavioural disorders: clinical descriptions and diagnostic guidelines*.
- World Health Organization. (2001). *The World health report : 2001 : Mental health : new understanding, new hope*.
- Zhdanova, M., Pilon, D., Ghelerter, I., Chow, W., Joshi, K., Lefebvre, P., & Sheehan, J. J. (2021). The Prevalence and National Burden of Treatment-Resistant Depression and Major Depressive Disorder in the United States. *The Journal of Clinical Psychiatry, 82*(2), 20m13699. <https://doi.org/10.4088/JCP.20m13699>



---

## LONELINESS AND COGNITIVE VULNERABILITY FACTORS: A SYSTEMATIC REVIEW FOCUSED ON MALADAPTIVE COGNITIONS

---

*Lia-Ecaterina Oltean<sup>1,2,a</sup>; Miruna-Gabriela Canache<sup>1,3,b</sup>;  
Andrei Patrichi<sup>1,3,b</sup>; Raluca Ioana Rîmbu<sup>1,3,b</sup>; Daria Sîntoma<sup>1,3,b</sup>;  
Andrei C. Miu<sup>4,a</sup>, Aurora Szentágotai-Tătar<sup>1,2,5,a\*</sup>*

<sup>1</sup> The International Institute for the Advanced Studies of Psychotherapy and Applied Mental Health, Babeş-Bolyai University, Cluj-Napoca, Romania

<sup>2</sup> Department of Clinical Psychology and Psychotherapy, Babeş-Bolyai University, Cluj-Napoca, Romania

<sup>3</sup> Evidence-Based Assessment and Psychological Interventions Doctoral School, Babeş-Bolyai University, Cluj-Napoca, Romania

<sup>4</sup> Cognitive Neuroscience Laboratory, Department of Psychology, Babeş-Bolyai University, Cluj-Napoca, Romania

<sup>5</sup> Applied Clinical Psychology Laboratory, Institute for Research, Development and Innovation in Biotechnologies, Babeş-Bolyai University, Cluj-Napoca, Romania

<sup>a</sup> PhD

<sup>b</sup> MA

---

### Abstract

We aimed to identify and report data from studies investigating associations between loneliness and maladaptive cognitions.

Eighteen studies were included in the present systematic review. Findings generally supported positive associations between loneliness and maladaptive cognitions, and this pattern was consistent across different types of cognitions. Maladaptive cognitions may represent vulnerability factors for loneliness, but given that most evidence comes from studies reporting cross-sectional data in convenience samples, further research is needed to clarify the nature and dynamic of the association.

Existing studies provide evidence for a relation between loneliness and maladaptive cognitions, and support the relevance of further research on this topic.

**Keywords:** loneliness; cognitive vulnerability; maladaptive cognitions; maladaptive schemas.

---

\* Correspondence concerning this article should be addressed to Aurora Szentágotai-Tătar, PhD, Department of Clinical Psychology and Psychotherapy, Babeş-Bolyai University, 37 Republicii, 400015 Cluj-Napoca, CJ, Romania.  
Phone/fax: +40-264-590967.  
E-mail: auraszentagotai@psychology.ro

Humans long for connections, and when a disparity occurs between the desired and actual quality and quantity of their social relationships, the aversive state of loneliness emerges (Heinrich & Gullone, 2006; Peplau & Perlman, 1982). Unlike social isolation, which refers to the objective state of having a reduced number of relationships (Hawkley & Cacioppo, 2010), or solitude, which describes a voluntary state of social distancing (Ong et al., 2015), loneliness is an experience characterized by subjective distress (Hawkley & Cacioppo, 2010). Transitory feelings of loneliness are common and thought to be adaptive, as they may signal a problem with social connections and motivate repair (Cacioppo & Hawkley, 2009). However, when loneliness is prolonged or severe, it loses its adaptive value, becoming a threat to wellbeing (Surkalim et al., 2022).

Given its increased prevalence among all age groups (Qualter et al., 2015), and its associations with a variety of physical and mental health problems (e.g., Holt-Lunstad et al., 2015; Wang et al., 2018), loneliness has been described as a public health concern (Hawkley & Cacioppo, 2010; Heinrich & Gullone, 2006), and research devoted to understanding and reducing this phenomenon has increased over the past years (Holmes et al., 2020). However, studies have mainly focused on objective factors that influence loneliness, while its subjective features remain less understood.

Still, prior work underscores their relevance. Research applying an emotion regulation framework indicates that loneliness is associated with decreased utilization of cognitive reappraisal, on the one hand, and increased propensity for self-blame, rumination, and catastrophizing, on the other (see Preece et al., 2021; Tan et al., 2022). As such, it points out cognitive factors. Indeed, socio-cognitive models emphasize the importance of cognitive factors in the emergence and maintenance of loneliness. For example, Hawkley and Cacioppo (2010) hypothesize that perceived social isolation leads to feelings of unsafety and hypervigilance to social threats, which trigger cognitive biases in the processing of social information. These biases elicit behaviours in oneself and subsequently from others that confirm the negative social expectations of lonely people, and lead to further distancing from potential social partners, and a self-reinforcing loneliness loop (Hawkley & Cacioppo, 2010).

A review (Heinrich & Gullone, 2006) documents this negative cognitive pattern, drawing attention to the self- and other-directed negative views (e.g., low self-esteem, inferiority, mistrust, cynicism etc.). Likewise, a more recent review of studies on the relation between information processing biases and loneliness supports this association (Spithoven et al., 2017), but other cognitive vulnerability factors have been investigated less. Among these, maladaptive cognitions are crucial, in light of their implications for psychopathology (e.g., Bridges & Harnish, 2010),

considering that loneliness is highly comorbid with various mental health issues (Erzen & Çikrikci, 2018; Maes et al., 2019; Shevlin et al., 2015).

Supporting this view, Young (1982) described “core lonely thoughts” (i.e., general cognitive structures shared by most lonely people), and “loneliness clusters” (i.e., content-specific structures consisting of automatic thoughts and maladaptive assumptions, and associated behavioural and emotional manifestations - e.g. low self-concept, mistrust, intimate rejection etc.). Nonetheless, the link between loneliness and specific maladaptive cognitions has not yet been synthesized. The goal of the current systematic review was to document findings of studies investigating this relation. Therefore, we focused on maladaptive cognitions in light of their status as cognitive vulnerability factors.

## **Method**

We conducted a systematic search in four bibliographic databases (PsychInfo, Scopus, PubMed and Web of Science). The search was conducted in April 2023, using keywords and truncated terms related to *loneliness* (loneliness OR “social isolation” OR lonel\* OR solitude) and *maladaptive cognitions* (schema\* OR “maladaptive schemas” OR “cognitive schemas” OR “early maladaptive schemas” OR EMS OR “maladaptive cognitions” OR “dysfunctional attitudes” OR “automatic thoughts” OR “irrational beliefs”).

### *Study Selection*

Study selection was conducted in line with PRISMA guidelines (Moher et al., 2009) and is depicted in Figure 1. The search yielded 614 records of which 290 remained after duplicate removal. Abstracts were screened, indicating 66 potentially relevant records. We had access to 61, and contacted the authors for the remaining 5 records. Following non-response from authors, 61 records were read full-text. Inclusion criteria were: (a) primary studies published in peer-reviewed journals, (b) in English that (c) investigated associations between loneliness and maladaptive cognitions (i.e., irrational beliefs, automatic thoughts, intermediate beliefs, core beliefs, early maladaptive schemas, and other cognitive schemas). Eighteen studies met inclusion criteria.

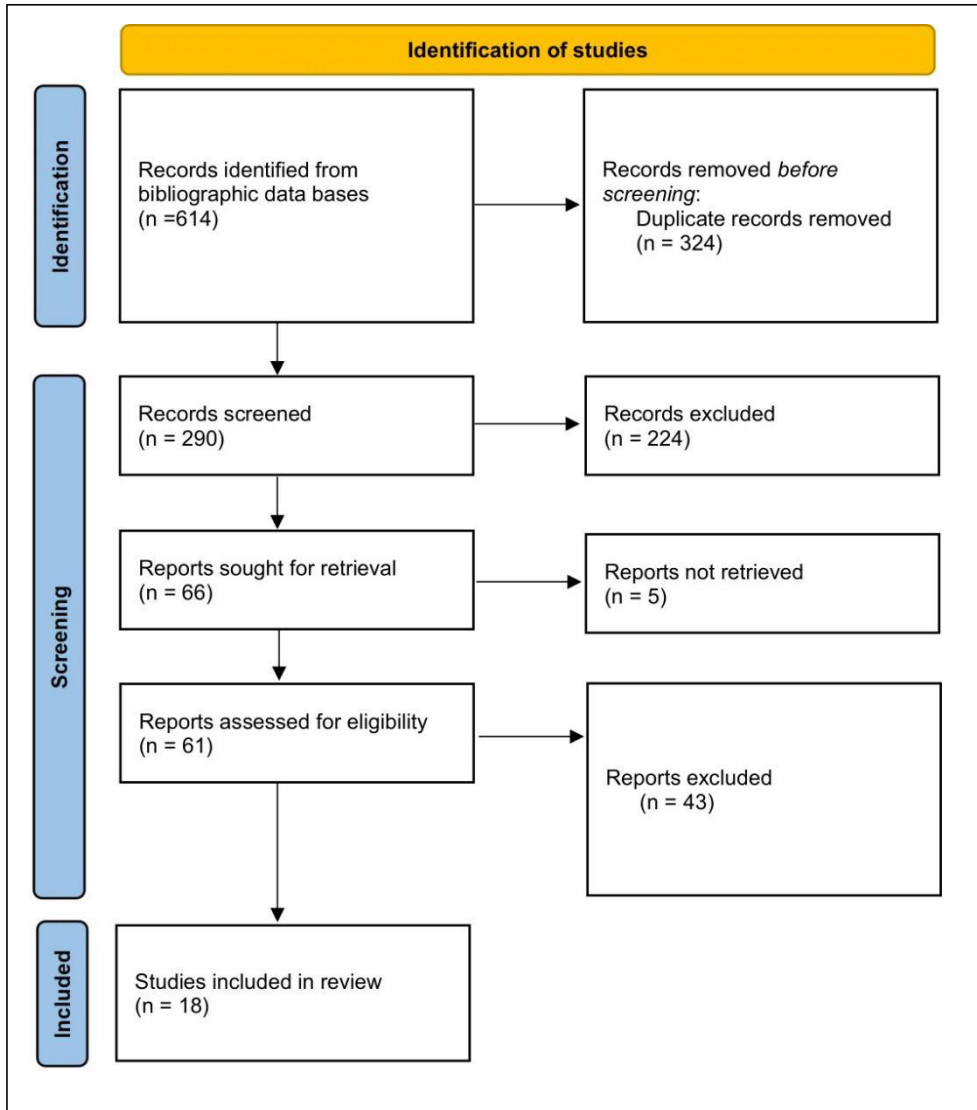

Figure 1. Prisma flowchart describing the selection of studies

*Procedure*

Two coders extracted study characteristics (Table 1). Consistent with our objective, a narrative review was performed.

Table 1. Study characteristics

Study	Country	N	Age (sd)	% F	Sample type	Clinical status	Study design	Relevant cognitions	Cognition measure	Loneliness measure	Key findings
Besser et al., 2022	Israel	462	28.41 (8.59)	75.5	students	non-clinical	cross-sectional	automatic thoughts (negative & positive); loneliness automatic thoughts	Automatic Thoughts Questionnaire - Short (ATQ-S; Netemeyer et al., 2002); Positive Automatic Thoughts Questionnaire (ATQ-P - 5 item adapted version; Ingram et al., 1995); Loneliness Automatic Thoughts Questionnaire (LATQ; Flett et al., 2021)	UCLA Loneliness Scale (8-item version; ULS-8; Hays & DiMatteo, 1987)	Loneliness was positively and strongly associated with negative and loneliness-related automatic thoughts, and negatively and strongly associated with positive automatic thoughts
Bonner & Rich, 1987	USA	158	NR	63.2	students	non-clinical	cross-sectional	irrational beliefs	Rational Behavior Inventory (RBI; Shorkey & Whiteman, 1977)	UCLA Loneliness Scale (ULS; Russell et al., 1978)	Loneliness was negatively and moderately associated with irrational beliefs
Bonner & Rich, 1990	USA	146	28.28 (6.67)	0	inmates	NR	cross-sectional	irrational beliefs	Rational Behavior Inventory (RBI; Shorkey & Whiteman, 1977)	UCLA Loneliness Scale (ULS; Russell et al., 1978)	Loneliness was negatively and moderately associated with irrational beliefs
Bonner & Rich, 1991	USA	178	NR	NR	students	non-clinical	longitudinal study reporting cross-sectional data	irrational beliefs	Rational Behavior Inventory (RBI; Shorkey & Whiteman, 1977)	UCLA Loneliness Scale (ULS; Russell et al., 1978)	Loneliness was positively and strongly associated with irrational beliefs
Botter et al., 2022	The Netherlands	1	63 (NR)	0	adult	clinical (personality disorder, substance use disorder, and cognitive	case study	early maladaptive schemas and schema modes	Young Schema Questionnaire (YSQ-L2 - Dutch adaptation; Rijkeboer et al., 2005); Schema Mode Inventory (SMI - Dutch adaptation; Lobbstaal et al., 2010)	NR	Feelings of loneliness decreased as a result of a schema therapy individual treatment

## Articles Section

Study	Country	N	Mean age (sd)	% F	Sample type	Clinical status (impairments)	Study design	Relevant cognitions	Cognition measure	Loneliness measure	Key findings
Chau et al., 2022	China	2089	23.63 (3.67)	68.4	adults	non-clinical	cross-sectional	core beliefs (negative and positive self & other-related beliefs)	The Brief Core Schema Scale (BCSS; Fowler et al., 2006)	UCLA Loneliness Scale (version 3; ULS-v3; Russell, 1996)	Higher levels of negative core beliefs (self and other-related) increase the chances of falling within a profile described by high loneliness and high psychopathology; higher levels of positive core beliefs (self and other-related) decrease the chances of falling within a profile described by high loneliness and high psychopathology
Halamandaris & Power, 1997	UK	124	24.4 (8.68)	69.4	students	non-clinical	cross-sectional	dysfunctional attitudes	The Dysfunctional Attitudes Scale (DAS; Weissman, 1980)	Revised UCLA Loneliness Scale (R-ULS; Russell et al., 1980)	Loneliness was positively and strongly associated with dysfunctional attitudes
Hyland et al., 2019	UK & Ireland	397	23.33 (7.91)	50.4	students	non-clinical	cross-sectional	irrational beliefs	The Attitudes and Belief Scale 2 - Abbreviated Version (ABS2-AV; Hyland et al., 2017)	UCLA Three-Item Loneliness Scale (ULS-3; Hughes et al., 2004)	Loneliness was positively and strongly associated with irrational beliefs. The tested model comprising of four irrational beliefs explained 36% of the variance in loneliness
Jalilian et al., 2023	Iran	338	25.09 (5.02)	75.7	students	non-clinical	cross-sectional	early maladaptive schemas (specific schemas pertaining to disconnection-rejection and other-directedness)	Young Schema Questionnaire (YSQ-SF; Young et al., 2003)	Social and emotional loneliness scale for adults (SELSA-S; DiTommaso et al., 2004)	Loneliness was positively and strongly associated with schemas from the disconnection and rejection domain. Loneliness presented a weak but positive association with schemas from the other-directedness domain

Study	Country	N	Age (sd)	% F	Sample type	Clinical status	Study design	Relevant cognitions	Cognition measure	Loneliness measure	Key findings
Jarvis et al., 2019	South Africa	32	74.93 (6.41)	81.3	adults (elderly, living in healthcare facilities)	NR	randomized controlled trial	early maladaptive schemas pertaining to disconnection-rejection	Young Schema Questionnaire - short form (YSQ-SF - Dutch version; Rijkeboer et al., 2005)	The De Jong Gierveld Short Scales for Emotional Loneliness (De Jong Gierveld & Van Tilburg, 2010)	The association between early maladaptive schemas and loneliness was not directly investigated. Decreases in loneliness levels at post-test were considered to be the result of EMS reduction at post-test
Lamster et al., 2017	Germany	65	40.49 (12.61)	56.9	adults	clinical (schizophrenia spectrum disorders)	cross-sectional	core beliefs (negative other-related beliefs)	The Brief Core Schema Scale (BCSS; Fowler et al., 2006)	UCLA Loneliness Scale (version 3; ULS-v3; Russell, 1996)	Loneliness was positively and strongly associated with other-related core beliefs
Leonova et al., 2021	NR	144	39.67 (6.12)	100	adults	non-clinical	cross-sectional	early maladaptive schemas (all); dysfunctional attitudes	Young Schema Questionnaire (YSQ-S3R - Russian adaptation; Kasyanik & Romanova, 2016); Dysfunctional Attitude Scale (DAS; Beck, 1979)	UCLA Loneliness Scale (version 3; ULS-v3; Russell, 1996)	Loneliness was positively and moderately associated with abandonment/ instability, social isolation/alienation, dependence/ incompetence, failure, and approval-seeking schemas, and positively and weakly associated with self-sacrifice schema; loneliness was positively and moderately associated with dysfunctional attitudes.
Moghadam et al., 2018	Iran	300	NR	NR	children (middle school students) and their mothers	non-clinical	cross-sectional	early maladaptive schemas (all - mother)	Young Schema Questionnaire - short form (YSQ-SF; Young, 1998)	Child Loneliness Scale (CLS; Asher & Wheeler, 1985)	Child loneliness was positively associated with all five maternal schema domains (medium to large associations)

## Articles Section

Study	Country	N	Mean age (sd)	% F	Sample type	Clinical status	Study design	Relevant cognitions	Cognition measure	Loneliness measure	Key findings
Reinhard et al., 2022	Germany	133	33.9 (12.8)	71.4	adults	mixed (including persistent depressive disorder and healthy controls)	cross-sectional	schema modes	Schema Mode Inventory - revised (SMI-R - German adaptation; Reiss et al., 2012)	Revised UCLA Loneliness Scale (R-ULS; Russell et al., 1980; German adaptation: Döring & Bortz, 1993)	Loneliness was positively and strongly associated with child modes (vulnerable child, undisciplined child, coping modes (bully and attack) and punitive modes (punitive parent); loneliness was negatively and strongly associated with contented child and healthy adult modes
Segel-Karpas & Ermer, 2021	USA	2130	64.81 (8.39)	50	adults	non-clinical	longitudinal	other cognitive schemas (i.e., cynical hostility)	Cook-Medley Hostility Inventory (Ho Scale; Cook & Medley, 1954; Costa et al., 1986)	UCLA Three-Item Loneliness Scale (ULS-3; Hughes et al., 2004)	For both men and women, loneliness (T1) presented positive weak to strong cross-sectional associations with cynical hostility (T1); loneliness (T2) presented positive and moderate longitudinal associations with cynical hostility (T1)
Serin et al., 2019	Turkey	287	NR	85.7	students	non-clinical	cross-sectional	dysfunctional attitudes	Dysfunctional Attitudes Scale (DAS - 10 item Turkish version; Batmaz & Ozdel, 2016)	NR	Loneliness was associated with dysfunctional attitudes; the direction and strength of the association were not reported.
Shareh et al., 2022	Iran	105	20.74 (2.98)	51.4	adults with gender dysphoria	Clinical	cross-sectional	emotional schemas	Leahy emotional schema scale (LESS; Leahy, 2002)	UCLA Loneliness Scale (ULS-v3; Russell, 1996)	Loneliness was positively and moderately associated with emotional schemas
Wilbert & Rupert, 1986	USA	50	18.9 (NR)	60	students	non-clinical	cross-sectional	dysfunctional attitudes	The Dysfunctional Attitudes Scale (DAS; Weissman, 1980); Young Loneliness Diagnostic Scale (YLD; Young, 1981)	Revised UCLA Loneliness Scale (R-ULS; Russell et al., 1980)	Loneliness was positively and strongly associated with dysfunctional attitudes

Notes: % F – percentage of females; NR - not reported

## *Findings*

### *Study characteristics*

Most studies used cross-sectional designs (77.8%) and employed non-clinical samples (66.7%). A minority of studies were conducted on clinical (16.6%) and mixed samples (5.6%) or samples where the clinical status was unclear (11.1%). Populations consisted of either students (44.4%) or other adult groups (50%); only one study was conducted on children (Moghadam et al., 2018). Information on mean age of participants and gender was generally included (77.8% and 88.9%, respectively), but could not be determined for all studies. Studies varied in terms of type of maladaptive cognitions they focused on and in terms of maladaptive cognitions measures, but little heterogeneity was observed concerning loneliness (see Table 1).

### *Loneliness and Irrational Beliefs*

Irrational beliefs are maladaptive thinking patterns that lack logical, empirical, and functional support (Ellis, 1994; David et al., 2019). Four types of irrational beliefs have been described (i.e., demandingness, catastrophizing, low frustration tolerance, and global evaluation of self/others/life, Ellis, 1977; David et al., 2019), and have been related with a variety of emotional and behavioural problems (see Browne et al., 2010 for a review).

Albeit limited, there is evidence suggesting that irrational beliefs may be relevant for loneliness, with several studies reporting significant associations between loneliness and irrational beliefs (Bonner & Rich, 1987; 1990; 1991; Hyland et al., 2019). Three older studies (Bonner & Rich, 1987, 1990, 1991) measured loneliness using the UCLA Loneliness Scale (ULS; Russell et al., 1978), and irrational beliefs with the Rational Behaviour Inventory (RBI; Shorkey & Whiteman, 1977). However, only one (Bonner & Rich, 1990) reported the scoring method for the RBI, although several distinct scoring methods are available for this measure (Thyer et al., 1981). In this study, loneliness was negatively associated with low RBI scores, which indicate the presence of high levels of irrational beliefs. Given that it is unclear how RBI scores were computed in the other two studies (Bonner & Rich, 1987, 1991), their findings should be interpreted with caution.

A more recent study (Hyland et al., 2019), found a positive relation between loneliness measured with the Three-Item Loneliness Scale (ULS-3; Hughes et al., 2004), and irrational beliefs measured with the Attitudes and Belief Scale 2-Abbreviated Version (ABS2-AV; Hyland et al., 2017). Irrational beliefs explained 36% of the variance of loneliness, and mediation analyses showed that increased levels of demandingness contributed to increased levels of loneliness through catastrophizing and self-downing. When the rational/adaptive alternatives of these beliefs were considered, the model explained 23% of the variance in loneliness (Hyland et al., 2019).

While these studies provide support for an association between loneliness and irrational beliefs, they all employ cross-sectional designs. Although there is one longitudinal study, data on the relation between loneliness and irrational beliefs are reported cross-sectionally (Bonner & Rich, 1990). More research is therefore needed to clarify this relation. Moreover, even though loneliness is a common experience across age groups (Qualter et al., 2015; Surkalim et al., 2022), all of the above studies were conducted on adults samples of either students (Bonner & Rich, 1987, 1991; Hyland et al., 2019) or inmates (Bonner & Rich, 1990).

*Loneliness, Core Beliefs, Dysfunctional Attitudes and Automatic Thoughts*

According to Beck (1979), interpreting and responding to life events is grounded in cognitive structures labelled cognitive schemas, which develop as a result of early life experiences (Beck & Bredemeier, 2016). Core beliefs are fundamental propositional structures within these schemas (Dozois & Beck, 2008). Dysfunctional views about oneself (e.g. unlovable, worthless, etc.) and others (e.g., rejecting, untrustworthy, etc.), which serve as an input for future negative expectations, play an important role in generating emotional and behavioural problems (Beck & Bredemeier, 2016).

Models of loneliness emphasize the importance of negative self- and other-related beliefs in problematic loneliness (Hawkley & Cacioppo, 2010). Although scarce, existing data support an association between loneliness and maladaptive core beliefs. For example, in a study that investigated the co-occurrence of loneliness with various symptoms, Chau et al. (2022) found that higher levels of positive core beliefs were associated with a decreased probability of loneliness, while higher levels of negative self- and other-related core beliefs were associated with an increased probability of loneliness. In latent class analysis, negative beliefs about others predicted profiles that included loneliness, but also symptoms such as paranoia suggesting that the associations may be stronger in clinical populations. A study that involved patients with schizophrenia spectrum disorders (Lamster et al., 2017) supports this hypothesis, as it reports strong positive associations between negative other evaluations and loneliness. However, given that both of these studies are cross-sectional and were conducted on adult samples consisting mostly of female participants (Chau et al., 2022; Lamster et al., 2017), this interpretation is tentative and requires further investigation.

Dysfunctional attitudes are so-called *intermediate beliefs*. They result from core beliefs, often reflect people's values, and, similar to core beliefs, they organize experience and influence feelings and behaviours (Beck, 2020; Dozois & Beck, 2008). A study conducted on a student sample found a strong positive association between dysfunctional attitudes (measured with the Dysfunctional Attitude Scale; DAS; Weissman, 1980) and loneliness (assessed with the Young Loneliness Diagnostic Scale; YLD; Young, 1981), which remained stable when controlling for depressive symptoms (Wilbert & Rupert, 1986). These results were replicated by

Halamandaris and Power (1997) who also suggest that the relation between loneliness and dysfunctional attitudes may be influenced by other factors such as extraversion, self-esteem and interpersonal mistrust. More recently, Leonova and colleagues (2021) reported positive associations between loneliness and dysfunctional attitudes, with stronger relations in the case of DAS items related to the approval of others.

Finally, automatic thoughts are situation-specific beliefs that emerge without one's control and are characterized by lack of deliberation (Dozois & Beck, 2008). While they are the most superficial level of beliefs, they stem from intermediate and core beliefs, and share similar functions (Dozois & Beck, 2008). Thus, automatic thoughts may also be relevant for loneliness, but the few studies that measure both constructs mostly look at them as parallel predictors of symptoms (e.g., depression) without reporting relations between them. We found one study (Besser et al., 2022) that reports a strong positive association of loneliness with negative automatic thoughts, and a strong negative association with positive automatic thoughts. A strong positive relation was also observed between loneliness and loneliness-specific automatic thoughts, measured with a scale specifically designed to assess these thoughts (i.e., the Loneliness Automatic Thoughts Questionnaire; Flett et al., 2021).

A limitation of the studies reviewed in this section is their cross-sectional nature. Longitudinal designs, and more diverse samples in terms of age and clinical status are needed in order to clarify the role of maladaptive cognitions in leading to and maintaining loneliness, and in distinguishing between transitory, functional feelings of loneliness, and chronic, problematic loneliness (Heinrich & Gullone, 2006).

#### *Loneliness and Early Maladaptive Schemas*

Early maladaptive schemas (EMS) are defined as “memories, emotions, cognitions, and bodily sensations regarding oneself and one's relationship with others” (Young et al., 2003, p. 7) that develop following recurrent failures to meet basic emotional needs during childhood (Bintaş-Zörer & Dirik, 2023). They impact the individual's mental health both during youth (Nicol et al., 2020) and adulthood (Thimm & Chang, 2022), and are associated with interpersonal maladjustment (Nordahl & Nysaeter, 2005) and dysfunction (Janovsky et al., 2020). While several domains of EMS have been described (see Young et al., 2003), those pertaining to the domains of *disconnection and rejection* (e.g., abandonment, mistrust/abuse, social isolation), and other-directedness (e.g., subjugation, self-sacrifice) have recently gained attention in loneliness research, with results generally reflecting positive associations between these constructs (Jalilian et al., 2023; Leonova et al., 2021; Moghadam et al., 2018).

A study that investigated relations between specific EMS and loneliness (Leonova et al., 2021) found medium positive associations with schemas of abandonment/instability, social isolation/alienation,

dependence/incompetence, failure, and approval-seeking, and a small positive association with self-sacrifice. Jalilian and colleagues (2023) found a similar pattern of results, with the largest associations emerging for the disconnection-rejection domain. Finally, in a study investigating the relation between mothers' EMS and their children's loneliness, Moghadam and colleagues (2018) reported medium to large positive associations between the two. These findings suggest that loneliness may also depend on others' maladaptive cognitions. Given that EMS develop in childhood, it is plausible that mothers model these cognitive patterns, which may in turn explain associations between the two reported later in life (e.g., Leonova et al., 2021).

Data also suggest significant associations between loneliness and schema modes (i.e., moment to moment, schema-driven, adaptive and maladaptive emotional and coping responses; Young et al., 2003). Reinhard and colleagues (2022) examined relations between schema modes and loneliness in adults with persistent depressive disorder and healthy controls. Patterns of associations were generally consistent across both groups, with results indicating large positive associations between loneliness and maladaptive child modes (i.e., vulnerable child, undisciplined child), coping modes (i.e., bully and attack), and punitive modes (i.e., punitive parent). Large negative associations were observed for healthy modes such as contented child and healthy adult (Reinhard et al., 2022).

A randomized controlled trial that evaluated the efficacy of low-intensity CBT in reducing loneliness in the elderly, by targeting maladaptive cognitions such as the disconnection-rejection schema, reported decreases in both loneliness and EMS following the intervention (Jarvis et al., 2019). However, considering that the study did not address the question of whether changes in EMS are associated with reductions in loneliness, it is unclear if the effect on loneliness may be attributed to changes in EMS. A case study that describes the use of schema therapy for a patient with a complex presentation of substance abuse and mixed personality disorder also reports reductions in loneliness after treatment (Botter et al., 2022), but the measure used to assess loneliness is not specified.

Although few and methodologically heterogeneous, these studies draw attention to the potential importance of EMS schemas in loneliness, particularly considering their impact on interpersonal functioning, and their established relations with interpersonal problems (see Janovsky et al., 2020 for a review).

#### *Loneliness and other cognitive schemas*

Emotional schemas are cognitive structures encompassing one's beliefs and attitudes toward emotions (Leahy, 2002). Given that loneliness is defined as a negative emotional state, emotional schemas may be relevant for how it is experienced. Shareh and colleagues (2022) investigated this hypothesis in a cross-sectional study that involved participants with gender dysphoria, and found a medium positive association between loneliness and emotional schemas. However,

further studies are needed to clarify this relation and the importance of emotional schemas for loneliness.

Finally, cynical hostility is another cognitive schema that has been linked to loneliness in a series of studies conducted by Segel-Karpas and colleagues (e.g., Segel-Karpas & Ayalot, 2020; Segel-Karpas & Ermer, 2021). Cynical hostility refers to beliefs that other people are not trustworthy and may cause one harm (Smith et al., 2004). Results of these studies indicate a bidirectional relation between loneliness and cynical hostility, both cross-sectionally and longitudinally (Segel-Karpas & Ayalot, 2020; Segel-Karpas & Ermer, 2021), supporting the hypothesis that lonely individuals have negative social expectations that end up being self-reinforced, including by the reactions they elicit from others (Hawley & Cacioppo, 2010).

## **Discussion**

The current review focused on factors contributing to the emergence and maintenance of loneliness, and synthesized existing data on its association with maladaptive cognitions. The review supports the hypothesis that maladaptive cognitions may be relevant in loneliness, with studies generally reporting positive associations between these constructs. Evidence seems stable across types of maladaptive cognitions and clinical conditions. Indirect support also comes from studies that report negative relations between loneliness and adaptive cognitions.

Thus, our review has several important theoretical implications. First, given the insufficiently understood subjective nature of loneliness and its underlying mechanisms, the review sheds light on factors explaining its emergence, as well as the transition from functional (temporary) to dysfunctional (chronic) loneliness. Second, it builds on existing theoretical models (Cacioppo & Hawley, 2010) to single out potentially understudied relevant factors. To our knowledge, this review is the first one to focus on maladaptive cognitions and document their contributions to loneliness. Third, given that it indicates associations are consistent for both maladaptive cognitions about self and others, the review extends existing models that posit altered cognitive processes contribute to enhanced threat of social world, and negative self perceptions (e.g., Hawley & Cacioppo, 2010).

Moreover, the review has practical implications, and it is timely to address issues pertaining to loneliness as a public health concern (Heinrich & Gullone, 2006). Notably, its findings are consistent with meta-analytical data advocating for interventions targeting social maladaptive cognitions (e.g. Masi et al., 2011). Given that existing interventions generally yield small effects (Masi et al., 2011), the current review suggests targeting these factors may improve treatments. As such, it advances other work focusing on loneliness and cognition (e.g., Heinrich & Gullone,

2006, Spithoven et al., 2017) and suggests interventions should target both low-level of processing social information (e.g. Jeong & Kim, 2021), and semantic processing, restructuring maladaptive cognitions (classic CBT).

However, there are some inherent limitations of the studies presented here. These ought to be considered, and subsequently addressed by future research. Given that most of the evidence comes from cross-sectional studies, and that temporal precedence between constructs cannot be established, the understanding of the interplay between loneliness and maladaptive cognitions is hampered. Although the cognitive model (Cacioppo & Hawkley, 2009) makes certain temporal assumptions, it is plausible for maladaptive cognitions to be both the effect or cause of loneliness (Spithoven et al., 2017). The only study so far reporting longitudinal data (Segel-Karpas & Ermer, 2021) found that negative cognitions predict loneliness, but more research using longitudinal designs is certainly needed to shed light on the dynamics of the relation between these variables.

Moreover, most studies examining the link between maladaptive cognitions and loneliness have been conducted on adult convenience samples, the vast majority including students, and predominantly women. While reliance on such samples is not surprising, further research is needed to generalize results to other populations. Loneliness is a common experience across the lifespan, and so are its deleterious effects (Qualter et al., 2015; Loades et al., 2020). Thus, it would be important to understand its relation with maladaptive cognitions at various ages. Similarly, clinical populations are underrepresented in the literature. However, clinical status may influence the association between loneliness and maladaptive cognitions, and should be taken into account in future research.

In addition, there is limited variability in measuring loneliness, as most studies used the ULS (Russell et al., 1978) or its alternatives. Although this scale has good psychometric properties (Alsubheen et al., 2023), it relies on an unidimensional conceptualization of loneliness (Peplau & Perlman, 1982). Yet, a more refined examination of its distinct dimensions (Heinrich & Gullone, 2006), including emotional/loneliness (Weiss, 1973), may clarify its relation with maladaptive cognitions. As such, future studies may delve into these issues using multidimensional measures of loneliness.

Finally, considering that loneliness is not always problematic and that transitory feelings of loneliness may serve adaptive purposes (Cacioppo & Hawkley, 2009), more attention should be devoted to distinguishing between temporary versus chronic loneliness, which entails a host of negative outcomes and is also more likely to be associated with maladaptive cognitions. Consequently, future research may consider using experience sampling methods (e.g., Tomoiagă et al., 2024) to differentiate between temporary and chronic loneliness. A better understanding of their involvement in loneliness could not only refine our understanding of this widespread phenomenon, but also pave the way for more efficient interventions aimed at reducing it.

## Authors' Notes

**Declaration of Interest.** The authors declare that there are no potential conflicts of interest associated with this publication, and that any financial support has been noted in the Acknowledgment section.

**Acknowledgement.** Aurora Szentágotai-Tătar was supported by a grant of the Romanian Ministry of Education and Research, CNCS - UEFISCDI, project number PN-III-P4-ID-PCE-2020-2894.

## References

- Alsubheen, S. A., Oliveira, A., Habash, R., Goldstein, R., & Brooks, D. (2023). Systematic review of psychometric properties and cross-cultural adaptation of the University of California and Los Angeles loneliness scale in adults. *Current Psychology*, 42(14), 11819–11833. <https://doi.org/10.1007/s12144-021-02494-w>
- Asher, S. R., & Wheeler, V. A. (1985). Children's loneliness: A comparison of rejected and neglected peer status. *Journal of Consulting and Clinical Psychology*, 53(4), 500–505. <https://doi.org/10.1037/0022-006X.53.4.500>
- Batmaz, S., & Ozdel, K. (2016). Psychometric Properties of the Revised and Abbreviated form of the Turkish Version of the Dysfunctional Attitude Scale. *Psychological Reports*, 118(1), 180–198. <https://doi.org/10.1177/0033294116628349>
- Beck, A. T. (1979). *Cognitive Therapy of Depression*. Guilford Press.
- Beck, A. T., & Bredemeier, K. (2016). A Unified Model of Depression: Integrating Clinical, Cognitive, Biological, and Evolutionary Perspectives. *Clinical Psychological Science*, 4(4), Article 4. <https://doi.org/10.1177/2167702616628523>
- Beck, J. S. (2020). *Cognitive behavior therapy: Basics and beyond*. Guilford Publications.
- Besser, A., Flett, G. L., Nepon, T., & Zeigler-Hill, V. (2022). Personality, Cognition, and Adaptability to the COVID-19 Pandemic: Associations with Loneliness, Distress, and Positive and Negative Mood States. *International Journal of Mental Health and Addiction*, 20(2), Article 2. <https://doi.org/10.1007/s11469-020-00421-x>
- Bintaş-Zörer, P., & Dirik, G. (2023). Social Anxiety from an Attachment Theory Perspective: The Mediating Role of Early Maladaptive Schema Domains and Rejection Sensitivity. *Journal of Evidence-Based Psychotherapies*, 23(2), 25–47. <https://doi.org/10.24193/jebp.2023.2.9>
- Bridges, K. R., & Harnish, R. J. (2010). Role of irrational beliefs in depression and anxiety: A review. *Health*, 02(08), Article 08. <https://doi.org/10.4236/>

health.2010.28130

- Bonner, R. L., & Rich, A. R. (1987). Toward a Predictive Model of Suicidal Ideation and Behavior: Some Preliminary Data in College Students. *Suicide and Life-Threatening Behavior*, *17*(1), Article 1.  
<https://doi.org/10.1111/j.1943-278X.1987.tb00061.x>
- Bonner, R. L., & Rich, A. R. (1990). Psychosocial vulnerability, life stress, and suicide ideation in a jail population: A cross-validation study. *Suicide & Life-Threatening Behavior*, *20*(3), Article 3.
- Bonner, R. L., & Rich, A. R. (1991). Predicting Vulnerability to Hopelessness: A Longitudinal Analysis. *The Journal of Nervous and Mental Disease*, *179*(1), Article 1. <https://doi.org/10.1097/00005053-199101000-00006>
- Botter, L., Gerritsen, D. L., & Oude Voshaar, R. C. (2022). Schema Therapy in the Nursing Home Setting: A Case Study of a Cognitively Impaired Patient. *Clinical Case Studies*, *21*(6), 552–570.  
<https://doi.org/10.1177/15346501221091790>
- Browne, C. M., Dowd, E. T., & Freeman, A. (2010). Rational and irrational beliefs and psychopathology. In *Rational and irrational beliefs: Research, theory, and clinical practice*. (pp. 149–171). Oxford University Press.
- Cacioppo, J. T., & Hawkley, L. C. (2009). Perceived Social Isolation and Cognition. *Trends in Cognitive Sciences*, *13*(10), Article 10.  
<https://doi.org/10.1016/j.tics.2009.06.005>
- Chau, A. K. C., So, S. H.-W., Sun, X., Zhu, C., Chiu, C.-D., Chan, R. C. K., & Leung, P. W. L. (2022). The co-occurrence of multidimensional loneliness with depression, social anxiety and paranoia in non-clinical young adults: A latent profile analysis. *Frontiers in Psychiatry*, *13*.  
<https://doi.org/10.3389/fpsy.2022.931558>
- Cook, W. W., & Medley, D. M. (1954). Proposed hostility and Pharisaeic-virtue scales for the MMPI. *Journal of Applied Psychology*, *38*(6), 414–418.  
<https://doi.org/10.1037/h0060667>
- Costa, P. T., Zonderman, A. B., McCrae, R. R., & Williams, R. B. (1986). Cynicism and paranoid alienation in the Cook and Medley HO Scale. *Psychosomatic Medicine*, *48*(3–4), 283–285.  
<https://doi.org/10.1097/00006842-198603000-00014>
- David, D. O., DiGiuseppe, R., Dobrea, A., Păsărelu, C. R., & Balazsi, R. (2019). The Measurement of Irrationality and Rationality. In M. E. Bernard & W. Dryden (Eds.), *Advances in REBT* (pp. 79–100). Springer International Publishing. [https://doi.org/10.1007/978-3-319-93118-0\\_4](https://doi.org/10.1007/978-3-319-93118-0_4)
- De Jong Gierveld, J., & Van Tilburg, T. (2010). The De Jong Gierveld short scales for emotional and social loneliness: Tested on data from 7 countries in the UN generations and gender surveys. *European Journal of Ageing*, *7*(2), 121–130.  
<https://doi.org/10.1007/s10433-010-0144-6>
- DiTommaso, E., Brannen, C., & Best, L. A. (2004). Measurement and Validity Characteristics of the Short Version of the Social and Emotional Loneliness

- Scale for Adults. *Educational and Psychological Measurement*, 64(1), 99–119. <https://doi.org/10.1177/0013164403258450>
- Döring, N., & Bortz, J. (1993). Psychometrische Einsamkeitsforschung: Deutsche Neukonstruktion der UCLA Loneliness Scale. [Psychometric research on loneliness: A new German version of the University of California at Los Angeles (UCLA) Loneliness Scale.]. *Diagnostica*, 39(3), 224–239.
- Dozois, D. J. A., & Beck, A. T. (2008). Cognitive schemas, beliefs and assumptions. In *Risk factors in depression* (pp. 121–143). Elsevier Academic Press. <https://doi.org/10.1016/B978-0-08-045078-0.00006-X>
- Ellis, A. (1977). Rational-emotive therapy: Research data that supports the clinical and personality hypotheses of RET and other modes of cognitive-behavior therapy. *The Counseling Psychologist*, 7(1), 2–42. <https://doi.org/10.1177/001100007700700102>
- Ellis, A. (1994). *Reason and Emotion in Psychotherapy. Revised and updated edition*. New York: Birch Lane Press.
- Erzen, E., & Çikrikci, Ö. (2018). The effect of loneliness on depression: A meta-analysis. *International Journal of Social Psychiatry*, 64(5), Article 5. <https://doi.org/10.1177/0020764018776349>
- Flett, G. L., Burdo, R., & Nepon, T. (2021). Mattering, Insecure Attachment, Rumination, and Self-Criticism in Distress Among University Students. *International Journal of Mental Health and Addiction*, 19(4), Article 4. <https://doi.org/10.1007/s11469-020-00225-z>
- Fowler, D., Freeman, D., Smith, B., Kuipers, E., Bebbington, P., Bashforth, H., Coker, S., Hodgekins, J., Gracie, A., Dunn, G., & Garety, P. (2006). The Brief Core Schema Scales (BCSS): Psychometric properties and associations with paranoia and grandiosity in non-clinical and psychosis samples. *Psychological Medicine*, 36(6), 749–759. <https://doi.org/10.1017/S0033291706007355>
- Halamandaris, K. F., & Power, K. G. (1997). Individual differences, dysfunctional attitudes, and social support: A study of the psychosocial adjustment to university life of home students. *Personality and Individual Differences*, 22(1), Article 1. [https://doi.org/10.1016/S0191-8869\(96\)00175-4](https://doi.org/10.1016/S0191-8869(96)00175-4)
- Hawkey, L. C., & Cacioppo, J. T. (2010). Loneliness Matters: A Theoretical and Empirical Review of Consequences and Mechanisms. *Annals of Behavioral Medicine*, 40(2), Article 2. <https://doi.org/10.1007/s12160-010-9210-8>
- Hays, R. D., & DiMatteo, M. R. (1987). A Short-Form Measure of Loneliness. *Journal of Personality Assessment*, 51(1), Article 1. [https://doi.org/10.1207/s15327752jpa5101\\_6](https://doi.org/10.1207/s15327752jpa5101_6)
- Heinrich, L. M., & Gullone, E. (2006). The clinical significance of loneliness: A literature review. *Clinical Psychology Review*, 26(6), Article 6. <https://doi.org/10.1016/j.cpr.2006.04.002>
- Holmes, E. A., O'Connor, R. C., Perry, V. H., Tracey, I., Wessely, S., Arseneault, L., Ballard, C., Christensen, H., Cohen Silver, R., Everall, I., Ford, T., John, A., Kabir, T., King, K., Madan, I., Michie, S., Przybylski, A. K., Shafran, R.,

- Sweeney, A., ... Bullmore, E. (2020). Multidisciplinary research priorities for the COVID-19 pandemic: A call for action for mental health science. *The Lancet. Psychiatry*, 7(6), 547–560. [https://doi.org/10.1016/S2215-0366\(20\)30168-1](https://doi.org/10.1016/S2215-0366(20)30168-1)
- Holt-Lunstad, J., Smith, T. B., Baker, M., Harris, T., & Stephenson, D. (2015). Loneliness and social isolation as risk factors for mortality: A meta-analytic review. *Perspectives on Psychological Science*, 10(2), 227–237. <https://doi.org/10.1177/1745691614568352>
- Hughes, M. E., Waite, L. J., Hawkey, L. C., & Cacioppo, J. T. (2004). A Short Scale for Measuring Loneliness in Large Surveys: Results From Two Population-Based Studies. *Research on Aging*, 26(6), Article 6. <https://doi.org/10.1177/0164027504268574>
- Hyland, P., Fox, R., Treacy, G., Maguire, P., Boduszek, D., & Vallières, F. (2017). Assessing the Factorial Validity of the Attitudes and Belief Scale 2-Abbreviated Version: A Call for the Development a Gold Standard Method of Measuring Rational and Irrational Beliefs. *Journal of Rational-Emotive & Cognitive-Behavior Therapy*, 35(2), Article 2. <https://doi.org/10.1007/s10942-016-0243-1>
- Hyland, P., McGinty, G., Karatzias, T., Murphy, J., Vallières, F., & McHugh Power, J. (2019). Can the REBT theory explain loneliness? Theoretical and clinical applications. *Cognitive Behaviour Therapy*, 48(1), Article 1. <https://doi.org/10.1080/16506073.2018.1475505>
- Ingram, R. E., Kendall, P. C., Siegle, G., Guarino, J., & McLaughlin, S. C. (1995). Psychometric properties of the Positive Automatic Thoughts Questionnaire. *Psychological Assessment*, 7(4), Article 4. <https://doi.org/10.1037/1040-3590.7.4.495>
- Jalilian, K., Momeni, K., & Jebraeili, H. (2023). The mediating role of early maladaptive schemas in the relationship between attachment styles and loneliness. *BMC Psychology*, 11(1), 136. <https://doi.org/10.1186/s40359-023-01172-9>
- Janovsky, T., Rock, A. J., Thorsteinsson, E. B., Clark, G. I., & Murray, C. V. (2020). The relationship between early maladaptive schemas and interpersonal problems: A meta-analytic review. *Clinical Psychology & Psychotherapy*, 27(3), 408–447. <https://doi.org/10.1002/cpp.2439>
- Jarvis, M. A., Padmanabhanunni, A., & Chipps, J. (2019). An Evaluation of a Low-Intensity Cognitive Behavioral Therapy mHealth-Supported Intervention to Reduce Loneliness in Older People. *International Journal of Environmental Research and Public Health*, 16(7), 1305. <https://doi.org/10.3390/ijerph16071305>
- Jeong, Y., & Kim, S. H. (2021). Modification of socioemotional processing in loneliness through feedback-based interpretation training. *Computers in Human Behavior*, 117, 106668. <https://doi.org/10.1016/j.chb.2020.106668>

- Lamster, F., Lincoln, T. M., Nittel, C. M., Rief, W., & Mehl, S. (2017). The lonely road to paranoia. A path-analytic investigation of loneliness and paranoia. *Comprehensive Psychiatry*, 74, 35–43. <https://doi.org/10.1016/j.comppsy.2016.12.007>
- Leahy, R. L. (2002). A model of emotional schemas. *Cognitive and Behavioral Practice*, 9(3), 177–190. [https://doi.org/10.1016/S1077-7229\(02\)80048-7](https://doi.org/10.1016/S1077-7229(02)80048-7)
- Leonova, I. M., Kiz, O. B., Dobrovolska, N. A., Chyzyk, K. O., & Hovorun, T. V. (2021). Cognitive Models of Loneliness in Women in Early and Middle Adulthood. *BRAIN. Broad Research in Artificial Intelligence and Neuroscience*, 12(4), Article 4.
- Loades, M. E., Chatburn, E., Higson-Sweeney, N., Reynolds, S., Shafran, R., Brigden, A., ... & Crawley, E. (2020). Rapid systematic review: the impact of social isolation and loneliness on the mental health of children and adolescents in the context of COVID-19. *Journal of the American Academy of Child & Adolescent Psychiatry*, 59(11), 1218-1239. <https://doi.org/10.1016/j.jaac.2020.05.009>
- Lobbestael, J., Arntz, A., & Bernstein, D. P. (2010). Disentangling the Relationship Between Different Types of Childhood Maltreatment and Personality Disorders. *Journal of Personality Disorders*, 24(3), Article 3. <https://doi.org/10.1521/pedi.2010.24.3.285>
- Maes, M., Nelemans, S. A., Danneel, S., Fernández-Castilla, B., Van den Noortgate, W., Goossens, L., & Vanhalst, J. (2019). Loneliness and social anxiety across childhood and adolescence: Multilevel meta-analyses of cross-sectional and longitudinal associations. *Developmental Psychology*, 55(7), 1548–1565. <https://doi.org/10.1037/dev0000719>
- Masi, C. M., Chen, H.-Y., Hawkley, L. C., & Cacioppo, J. T. (2011). A meta-analysis of interventions to reduce loneliness. *Personality and Social Psychology Review: An Official Journal of the Society for Personality and Social Psychology, Inc*, 15(3), 219–266. <https://doi.org/10.1177/1088868310377394>
- Moghadam, F., Davarinia, A., & Shomia, S. (2018). The Role of Mother's Early Maladaptive Schema in Predicting Early Maladaptive Schemas and Loneliness of Children Aged 8 to 15 Years in Amol City, Iran. *JOURNAL OF CLINICAL AND DIAGNOSTIC RESEARCH*, 12. <https://doi.org/10.7860/JCDR/2018/36369.12072>
- Moher, D., Liberati, A., Tetzlaff, J., Altman, D. G., & PRISMA Group. (2009). Preferred reporting items for systematic reviews and meta-analyses: The PRISMA statement. *PLoS Medicine*, 6(7), e1000097. <https://doi.org/10.1371/journal.pmed.1000097>
- Netemeyer, R., Williamson, D., Burton, S., Biswas, D., Jindal, S., Grau, S., Mills, G., & Premeaux, S. (2002). Psychometric Properties of Shortened Versions of the Automatic Thoughts Questionnaire. *Educational and Psychological Measurement - EDUC PSYCHOL MEAS*, 62, 111–129. <https://doi.org/10.1177/0013164402062001008>

- Nicol, A., Mak, A. S., Murray, K., Walker, I., & Buckmaster, D. (2020). The relationships between early maladaptive schemas and youth mental health: A systematic review. *Cognitive Therapy and Research*, 44(4), 715–751. <https://doi.org/10.1007/s10608-020-10092-6>
- Nordahl, H. M., & Nysaeter, T. E. (2005). Schema therapy for patients with borderline personality disorder: A single case series. *Journal of Behavior Therapy and Experimental Psychiatry*, 36(3), 254–264. <https://doi.org/10.1016/j.jbtep.2005.05.007>
- Ong, A. D., Uchino, B. N., & Wethington, E. (2015). Loneliness and Health in Older Adults: A Mini-Review and Synthesis. *Gerontology*, 62(4), Article 4. <https://doi.org/10.1159/000441651>
- Peplau, L. A., & Perlman, D. (1982). Loneliness: A sourcebook of current theory, research, and therapy. *Journal of Psychosocial Nursing and Mental Health Services*, 22(6), pp. 40–41
- Preece, D. A., Goldenberg, A., Becerra, R., Boyes, M., Hasking, P., & Gross, J. J. (2021). Loneliness and emotion regulation. *Personality and Individual Differences*, 180. <https://doi.org/10.1016/j.paid.2021.110974>
- Qualter, P., Vanhalst, J., Harris, R., Van Roekel, E., Lodder, G., Bangee, M., Maes, M., & Verhagen, M. (2015). Loneliness Across the Life Span. *Perspectives on Psychological Science*, 10(2), Article 2. <https://doi.org/10.1177/1745691615568999>
- Reinhard, M. A., Popov, N., Rek, S. V., Nenov-Matt, T., Barton, B. B., Jobst, A., Musil, R., & Padberg, F. (2022). Loneliness is associated with maladaptive schema modes in patients with persistent depressive disorder. *Journal of Psychiatric Research*, 154, 56–60. <https://doi.org/10.1016/j.jpsychires.2022.07.057>
- Reiss, N., Dominiak, P., Harris, D., Knörnschild, C., Schouten, E., & Jacob, G. A. (2012). Reliability and validity of the German version of the Schema Mode Inventory. *European Journal of Psychological Assessment*, 28(4), 297–304. <https://doi.org/10.1027/1015-5759/a000110>
- Rijkeboer, M. M., van den Bergh, H., & van den Bout, J. (2005). Stability and discriminative power of the Young Schema-Questionnaire in a Dutch clinical versus non-clinical population. *Journal of Behavior Therapy and Experimental Psychiatry*, 36(2), 129–144. <https://doi.org/10.1016/j.jbtep.2004.08.005>
- Russell, D., Peplau, L. A., & Cutrona, C. E. (1980). The revised UCLA Loneliness Scale: Concurrent and discriminant validity evidence. *Journal of Personality and Social Psychology*, 39(3), Article 3. <https://doi.org/10.1037/0022-3514.39.3.472>
- Russell, D., Peplau, L. A., & Ferguson, M. L. (1978). Developing a Measure of Loneliness. *Journal of Personality Assessment*, 42(3), Article 3. [https://doi.org/10.1207/s15327752jpa4203\\_11](https://doi.org/10.1207/s15327752jpa4203_11)
- Russell, D. W. (1996). UCLA Loneliness Scale (Version 3): Reliability, Validity, and Factor Structure. *Journal of Personality Assessment*, 66(1), Article 1.

- [https://doi.org/10.1207/s15327752jpa6601\\_2](https://doi.org/10.1207/s15327752jpa6601_2)
- Segel-Karpas, D., & Ermer, A. (2021). Cynical Hostility and Loneliness in Older Adult Married Couples: An Indirect Effect Through Friendships. *The Journals of Gerontology: Series B*, 76(2), 306–316. <https://doi.org/10.1093/geronb/gbaa170>
- Segel-Karpas, D., & Ayalon, L. (2020). Loneliness and hostility in older adults: A cross-lagged model. *Psychology and Aging*, 35(2), 169–176. <https://doi.org/10.1037/pag0000417>
- Serin, E. K., Durmaz, Y. Ç., & Polat, H. T. (2019). Correlation between smartphone addiction and dysfunctional attitudes in nursing/midwifery students. *Perspectives in Psychiatric Care*, 55(4), 703–709. <https://doi.org/10.1111/ppc.12406>
- Shareh, H., Bakhshandeh Sajjad, A., Hamedani, A., & Rajabi Gol, B. (2022). Relationship between personality traits and emotional schema with loneliness in Iranian people with gender dysphoria: The mediating role of mindfulness. *Sexual and Relationship Therapy*, 0(0), 1–14. <https://doi.org/10.1080/14681994.2022.2139822>
- Shevlin, M., McElroy, E., & Murphy, J. (2015). Loneliness mediates the relationship between childhood trauma and adult psychopathology: Evidence from the adult psychiatric morbidity survey. *Social Psychiatry and Psychiatric Epidemiology*, 50(4), Article 4. <https://doi.org/10.1007/s00127-014-0951-8>
- Shorkey, C. T., & Whiteman, V. L. (1977). Development of the Rational Behavior Inventory: Initial Validity and Reliability. *Educational and Psychological Measurement*, 37(2), Article 2. <https://doi.org/10.1177/001316447703700232>
- Smith, T. W., Glazer, K., Ruiz, J. M., & Gallo, L. C. (2004). Hostility, anger, aggressiveness, and coronary heart disease: An interpersonal perspective on personality, emotion, and health. *Journal of Personality*, 72(6), 1217–1270. <https://doi.org/10.1111/j.1467-6494.2004.00296.x>
- Spithoven, A. W. M., Bijttebier, P., & Goossens, L. (2017). It is all in their mind: A review on information processing bias in lonely individuals. *Clinical Psychology Review*, 58, 97–114. <https://doi.org/10.1016/j.cpr.2017.10.003>
- Surkalim, D. L., Luo, M., Eres, R., Gebel, K., Van Buskirk, J., Bauman, A., & Ding, D. (2022). The prevalence of loneliness across 113 countries: Systematic review and meta-analysis. *BMJ*, e067068. <https://doi.org/10.1136/bmj-2021-067068>
- Tan, A. J., Mancini, V., Gross, J. J., Goldenberg, A., Badcock, J. C., Lim, M. H., Becerra, R., Jackson, B., & Preece, D. A. (2022). Loneliness Versus Distress: A Comparison of Emotion Regulation Profiles. *Behaviour Change*, 39(3), 180–190. <https://doi.org/10.1017/bec.2022.18>
- Thimm, J. C., & Chang, M. (2022). Early Maladaptive Schemas and Mental Disorders in Adulthood: A Systematic Review and Meta-analysis. *International Journal of Cognitive Therapy*, 15(4), 371–413. <https://doi.org/10.1007/s41811-022-00149-7>
- Thyer, B. A., Papsdorf, J. D., Himle, D., & Bray, H. (1981). Normative Data of the Rational Behavior Inventory: A Further Study. *Educational and Psychological*

- Measurement, 41(3), 757–760. <https://doi.org/10.1177/001316448104100314>
- Tomoiağă, C., Gheorghiu, R., & David, O. A. (2024). USABILITY OF AN ECOLOGICAL MOMENTARY ASSESSMENT APP FOR MOOD EVALUATION IN YOUNG ADULTS - THE MOODWHEEL APP. *Journal of Evidence-Based Psychotherapies* <https://doi.org/10.24193/jebp.2024.1.8>
- Wang, J., Mann, F., Lloyd-Evans, B., Ma, R., & Johnson, S. (2018). Associations between loneliness and perceived social support and outcomes of mental health problems: A systematic review. *BMC Psychiatry*, 18(1), 156. <https://doi.org/10.1186/s12888-018-1736-5>
- Weiss, R. (1975). *Loneliness: The Experience of Emotional and Social Isolation* (New edition). The MIT Press.
- Weissman, A. N. (1980). Assessing depressogenic attitudes: A validation study. In *51st annual meeting of the Eastern Psychological Association, Hartford, CT*.
- Wilbert, J. R., & Rupert, P. A. (1986). Dysfunctional attitudes, loneliness, and depression in college students. *Cognitive Therapy and Research*, 10(1), Article 1. <https://doi.org/10.1007/BF01173384>
- Young, J. E., Klosko, J. S., & Weishaar, M. E. (2003). *Schema Therapy: A Practitioner's Guide*. Guilford Press.
- Young, J., & Brown, G. (1998). *Schema Questionnaire Short Form*. New York: Cognitive Therapy Center.
- Young, J. E. (1981). *Young loneliness inventories*. Unpublished manuscript, University of Pennsylvania

## ADAPTATION AND VALIDATION OF THE METEOROPATHY QUESTIONNAIRE TO THE TURKISH SAMPLE

*Cennet Yastıbaş-Kaçar<sup>1</sup>, İmran Gökçen Yılmaz-Karaman<sup>2\*</sup>, Marianna Mazza<sup>3</sup>*

<sup>1</sup> Psychologist, PhD. Faculty of Humanities and Social Sciences, Adana Alparslan Türkeş Science and Technology University, Adana, Türkiye. ORCID ID: <https://orcid.org/0000-0002-8871-3245>.

E-mail: [cennetyastibas@gmail.com](mailto:cennetyastibas@gmail.com)

<sup>2</sup> Psychiatrist. Department of Psychiatry, Faculty of Medicine, Eskişehir Osmangazi University, Eskişehir, Türkiye. ORCID ID: <https://orcid.org/0000-0003-2821-7749>.

E-mail: [gokcenyilmz@yahoo.com](mailto:gokcenyilmz@yahoo.com)

<sup>3</sup> Psychiatrist. Institute of Psychiatry and Psychology, Department of Geriatrics, Neuroscience and Orthopedics, Fondazione Policlinico Universitario A. Gemelli IRCCS, 00168 Rome, Italy; Department of Psychiatry, Università Cattolica del Sacro Cuore, 00168 Rome, Italy. ORCID ID: <https://orcid.org/0000-0002-3007-8162>.

E-mail: [mariannamazza@hotmail.com](mailto:mariannamazza@hotmail.com)

### Abstract

The present study aimed to adapt and evaluate the psychometric properties of the Meteoropathy Scale (METEO-Q) for the Turkish population. Furthermore, it aims to suppress some limitations of the original study by examining construct validity and test-retest reliability, and associations between certain variables. A total of 603 participants ( $M=34,92$ ,  $SD=13,57$ ) were recruited. METEO-Q, Seasonal Pattern Assessment Questionnaire (SPAQ), and sociodemographic form were utilized to collect data. To test the construct validity, exploratory factor analysis and confirmatory factor analysis were carried out. The exploratory factor analysis result pointed out the presence of a two-factor structure. Two-factor structure exhibited a reasonable model fit in the confirmatory factor analysis. The two factors (meteorosensitivity and meteoropathy), structured checklist and, total score of METEO-Q indicated good reliability ( $\alpha = .86, .88, .95, .93$ , respectively). Test-retest reliability scores demonstrated good reliability. The METEO-Q score was positively associated with SPAQ, gender, self-mutilation, and suicidal behaviors. In conclusion, the Turkish version of METEO-Q provides a valid and reliable measurement tool for the general population.

\* Correspondence concerning this article should be addressed to İmran Gökçen YILMAZ-KARAMAN, Department of Psychiatry, Faculty of Medicine, Eskişehir Osmangazi University, Eskişehir, Turkey. E-mail: [gokcenyilmz@yahoo.com](mailto:gokcenyilmz@yahoo.com)

**Keywords:** meteoropathy, meteorosensitivity, scale adaptation, construct validity, reliability.

The ancient Greeks realized a relationship between the weather and people's health. Thus, they created the term meteoropathy from the combination of the Greek words *meteora* and *pathos* (Žikić & Rabi-Žikić, 2018). Meteoropathy means weather-related illness, symptom, pain. It impacts every facet of an individual's life (Celic et al., 2019). Temperature, humidity, barometric pressure, and the degree of brightness of the sun are the variables that come to mind when it comes to weather. A sudden or severe change in at least one of these variables causes mental and physical symptoms in susceptible individuals: headache, weakness, sensitivity to muscle and joint pain, depressed mood, irritability, and palpitation. These symptoms often regress within a day or two (Mazza et al., 2012).

Meteorosensitive people are those who have a biological predisposition to experiencing the effects of changes in the climate on their mental and physical state. The quantity of this sensitivity is different among meteoropathic individuals—those who develop a particular illness or worsen existing health conditions due to these changes. Some people experience new symptoms; on the other hand, some face a worsening of pre-existing diseases (Mazza et al., 2012). Meteoropathy is more severe in women, middle-aged or older people, and those with chronic diseases (Licanin et al., 2012). In addition, meteoropathy can be seen in children, too (Janiri et al., 2009). Meteoropathy is believed to be a condition of modern times, where people often spend time indoors. People who do physical activity and spend a few hours a day outside generally do not experience weather-related discomfort (Janiri et al., 2009). To sum up, meteoropathy can expand in this century due to a person's poor adaptation to the weather conditions by spending less time outdoors, i.e., in climate-controlled conditions (Lickiewicz et al., 2020).

It has been shown in the literature that very low-frequency atmospheric cause physical and chemical effects on the human body and cause physical and mental symptoms in sensitive people. For example, as notified in Dorno's case report in 1934, the tinnitus symptom that occurred after the war changed with the impulse rate of the atmosphere. Reiter, on the other hand, determined the relationship between pain sensitivity and very low-frequency atmospheric in damaged tissues in the 1960s (Schienle et al., 1998). Jakobi and colleagues suggested that atmospheric pressure is a biological stressor that increases platelet adhesion (Jacobi et al., 1981). Participants with high psychasthenia scores in the Minnesota Multidimensional Personality Inventory were more affected by low-frequency atmospheric (Jacobi et al., 1981).

When healthy subjects were exposed to low-frequency atmospheric, EEG changes occurred in alpha and beta frequencies. Persons with meteoropathy or meteorosensitivity complaints more frequently reported symptoms during exposure,

but there was no significant difference in their EEG compared to the control group (Schienle et al., 2001).

In a study conducted with healthy individuals, there was a stronger correlation between rheoencephalography findings and fluctuations in weather conditions in men than in women (Vodolazhskaya & Vodolazhskii, 2016). In the same study, cerebral weather sensitivity was most common in the post-ovulatory phase in non-meteoropathic women, and cerebral weather sensitivity was rarely seen in the preovulatory phase (Vodolazhskaya & Vodolazhskii, 2016).

Air temperature regulates brain development by changing gene expression and neuronal structure in animal experiments. Furthermore, ambient temperature affects neurogenesis in the adult human brain and mental health is adversely affected in people who have short-term exposure to harsh weather conditions and are exposed to hurricanes (Ruszkiewicz et al., 2019).

A person suffering from psychiatric problems could be more vulnerable to weather and climatic variations (Janiri et al., 2009; Di Nicola et al., 2020; Oniszczenko, 2020). For instance, meteoropathy is associated with suicide attempts in bipolar disorder patients (Di Nicola et al., 2020). Oniszczenko (2020) claimed meteorosensitivity is associated with mood-related affective temperaments and has mediated the relationship between insomnia and affective temperament. Weather conditions are also associated with seasonal affective disorder (Oniszczenko, 2020). Individuals with a high degree of seasonality exhibited a tendency to respond emotionally to the weather conditions (Reid et al., 2000). The relationship between psychiatric diseases and meteoropathy draws attention. Furthermore, physical conditions have also been affected by weather variations. For example, total knee arthroplasty patients reported that meteoropathy could trigger their pain (Loth et al., 2018).

As given in the related literature, meteoropathy draws attention from researchers due to atmospheric events being an important factor affecting the mental and physical well-being of individuals. The Meteoropathy Scale was developed by Mazza et al. (2012) and subsequently studied across various populations to assess meteoropathy. Unfortunately, there is currently no validated measurement tool to assess meteoropathy in the Turkish population. Furthermore, the original developmental study of the Meteoropathy scale has some limitations on validity and reliability analyses. Specifically, the original study did not perform both exploratory and confirmatory factor analyses to test construct validity and did not examine test-retest reliability. Thus, the present study aims to test the Turkish validity and reliability of the Meteoropathy Questionnaire (METEO-Q) while addressing certain limitations of the original study. Specifically, we aimed to expand the original scale study of METEO-Q by testing the scale's construct validity with exploratory and confirmatory factor analyses. Furthermore, we aimed to expand reliability by performing test-retest reliability and to explore the associations with the Turkish

version of the METEO-Q with the seasonality and symptom severity of seasonal affective disorder scale, gender, and certain psychiatric conditions.

## **Method**

### *Participants*

A convenience sample of 603 participants was enrolled in this study. All participants confirmed the study with informed consent before receiving the related measurement tools. Their ages ranged from 18 and 87 years ( $M=34.92$ ,  $SD=13.57$ ). A total of 339 (56.2%) were female, and 43,8% were male participants. Most of the participants graduated from a university (55.4%). Regarding marital status, 23.4% were in a relationship, 36.3% were single, and 40.3% were married. Most of the participants (54.6%) had full-time jobs. A second sample of 44 participants was recruited for test-retest reliability analysis. The mean age was found to be 21.68 ( $SD = 4.88$ ), ranging between 18 and 50 for this small sample. Most of the participants (81.8%) were female, and 40.9% of the participants were in a relationship, whereas 59.1% of the participants were single. Half of them (50%) completed high school and the rest attended university. None of them had a full-time job.

### *Instruments*

#### *Sociodemographic data form*

The researchers use that to investigate the descriptive demographic forms of the participants, such as age, gender, educational level, marital status, occupation, and whether the participants have any disease history.

#### *METEO-Q*

We used the METEO-Q developed by Mazza et al. (2012) to adapt and examine the psychometric properties of the Turkish population. The 11-item METEO-Q contains two parts: meteorosensitivity and meteoropathy. Meteorosensitivity refers to the body and mind's biological susceptibility to atmospheric events. Meteoropathy is about suffering from the development of a particular illness or experiencing a worsening of an existing disease due to climatic changes. The first five items of the measurement assess meteorosensitivity both qualitatively and quantitatively. After rating the first five items, participants were instructed to write about any induced modifications for each item, following the given instruction: "specify induced modifications". The subsequent six items of the METEO-Q measure meteoropathy, focusing on the quantified effects of the symptoms. There is also a 21-item structured symptom checklist for the physical and psychological symptoms associated with climatic changes at the end of the scale.

Participants were asked to rate the extent to which they experienced each item based on a 5-point Likert scale ranging from 0 (absent) to 4 (severe). The descriptive statistics of the questionnaire are presented at Table 1 and Table 2.

#### *Seasonal Pattern Assessment Questionnaire (SPAQ)*

SPAQ was developed by Rosental et al. (1987) to investigate seasonal affective disorder. The Turkish adaptation study was conducted by Noyan et al. (2000). The Turkish form of SPAQ has two factors: sleep, mood, social activity, and energy; the other factors are appetite and weight, according to the factor analysis results. The first six items were about the global seasonality, and the internal consistency of the global seasonality was found. 67. The global seasonal scale exhibited good internal consistency (Cronbach alpha score was .87) in our study.

#### *Procedure*

First, the researchers requested permission for the Turkish adaptation of METEO-Q from Dr. Mazza, the questionnaire developer. Eskişehir Osmangazi University Faculty of Medicine, the Non-Invasive Clinical Research Ethics Committee, approved the present study on December 30, 2020, with decision number 57. The English version of METEO-Q was translated into Turkish by the two independent researchers who have good command on English, and two different forms were subsequently compared to decide the best version of the scale. The obtained form was back-translated by a separate researcher proficient in both English and Turkish. The researchers discussed the potential differences between the original and back-translation forms of the scale. Finally, after sending the translated form to Dr. Mazza, who conducted the original scale review, the final form was obtained. Afterward, we carried out an online survey using Google Forms. The data were collected from social media (e.g., Twitter, Instagram). In addition Evrim Ağacı also shared the link of study on its platform. Online informed consent was obtained by all participants. The measurement set was delivered in the following order: sociodemographic form, METEO-Q, and SPAQ. The online survey took an average of 15 minutes to complete. For the test-retest reliability analysis, we created a new online survey in which it is required to use a nickname and an e-mail or telephone number. After four weeks, we remind the participants to attend the second survey.

#### *Statistical Analysis*

The data for the study were analyzed with IBM SPSS version 23 and LISREL Package Program 8.80. First, 603 samples were used to analyze the item distributions. Normality assumptions were checked before the analysis of the study. According to Tabachnick et al. (2013), skewness and kurtosis should be between -1 and +1 for the data to be considered normally distributed. There is no missing data. Afterward, we randomly split the data into two subsamples for exploratory factor analysis (EFA) ( $n= 300$ ) and confirmatory factor analysis (CFA) ( $n= 303$ ). It should

be: "Afterward, we randomly split the data into two subsamples for exploratory factor analysis (EFA) ( $n= 300$ ) and confirmatory factor analysis (CFA) ( $n= 303$ ). For exploratory factor analysis, we enrolled 300 participants and ran a Principal Component Analysis with Promax rotation with all METEO-Q items consistent with the original scale. After examining the exploratory factor analysis of the scale, we ran confirmatory factor analysis models to verify the validity of METE-Q by using LISREL Package Program version 8.80 with the remaining 303 random participants. The Comparative Fit Index (CFI), the root of the mean square error of approximation (RMSEA), the Standardized Root Mean Square Residual (SRMR), and the chi-square/degrees of freedom were chosen as model fit indices. To get an acceptable model, CFI should be equal to .90 or above (Schermelleh-Engel et al., 2003), RMSEA values should be .08 or below, SRMR should be equal to .05 or below, and the normed chi-square or degrees of freedom should be below 3 (Schermelleh-Engel et al., 2003). The Pearson's correlation analysis was conducted to evaluate the association between scores on METEO-Q and SPAQ. Cronbach's alpha, item-total correlation, and test-retest were used to evaluate the internal consistency and reliability. An independent sample *t*-test was performed to examine scores differences in sociodemographic factors.

## Results

### Exploratory Factor Analysis

We investigated the factor structure of the METEO-Q using exploratory factor analysis by using a subsample. Kaiser-Meyer-Olkin value was .938 and Bartlett's Test of Sphericity was significant ( $\chi^2(55)=2277.875, p=.000$ ). Based on the Kaiser criterion, two factor structure (meteorosensitivity and meteoropathy) were extracted, accounting for 68.59% of the total variance. While examining the two-factor solution, all 11 items had good factor loading. As can be seen in Table 1, the factor loading of the Turkish form of METEO-Q ranged between .93 and .50. In other words, each item of the scale significantly contributes to the two-factors at good and excellent levels.

**Table 1.** Descriptive statistics and exploratory factor analysis results of METEO-Q

METEO-Q	Mean	SD	Skewness	Curtosis	Item-Total correlation	Factor loading	
						1	2
<b>Factor 1: Meteorosensitivity</b>							
1. Variations of mood in relation to the change of latitude, the geographic zone, the jet leg.	.60	.88	1.40	1.24	.588	.926	

METEO-Q	Mean	SD	Skewness	Curtosis	Item-Total correlation	Factor loading	
						1	2
<b>Factor 1: Meteorosensitivity</b>							
2. Variations of mood in relation to atmospheric changes (e.g.: when it begins or when it stops raining, when it's cloudy, when it's sunny or when the sun suddenly goes down, when humidity increases).	1.24	1.08	.49	-.66	.806		.664
3. Variations of mood in relation to the brightness of the sky (when days are more or less luminous or when days "grow tall" or "they are shortened" according to the seasons).	1.28	1.20	.35	-1.27	.808		.682
4. Variations of mood caused by the temperature changes (warmer or colder days).	1.25	1.57	.52	-.83	.793		.844
5. Mood changes caused by the seasons changing.	1.17	1.13	.58	-.75	.821		.668
<b>Factor 2: Meteoropathy</b>							
6. Indicate the degree of relation between the set in symptomatology and the climatic or atmospheric change.	1.29	1.10	.53	-.51	.880		.502
7. Tendency of these disturbs to minimize or disappear when the triggering condition stops or when an opposite environmental condition comes up.	1.24	1.15	.41	-1.14	.779		.801
8. Eventual coincidence of these disturbs with other cyclical phenomena (e.g. menstrual cycle).	.82	1.16	1.28	.33	.702		.783
9. Presence of prodromical symptoms few days before the climatic modifications (irritability, weariness...).	.72	.94	1.20	.66	.723		.909
10. Interference with daily activities due to disturbs induced by climatic changes.	1.08	1.06	.72	-.28	.813		.807
11. Uneasiness feelings induced by climatic changes.	1.09	1.05	.70	-.34	.843		.853

**Table 2.** Descriptive Results of Symptom Checklist

	Mean	SD
Lability of mood	1.39	1.18
Reactivity to external events	1.15	1.14
Depression	1.19	1.14
Anxiety	1.48	1.25
Asthenia	1.51	1.19
Anhedonia	1.64	1.20
Irritability	1.23	1.19
Indefinite feeling of uneasiness	1.53	1.26
Pain	.95	1.19
Vertigo	.36	.77
Headache	.95	1.12
Nausea	.27	.67
Alterations of cardiac rhythm	.44	.82
Concentration difficulties	1.18	1.21
Insomnia	1.13	1.22
Excessive sleepiness	1.31	1.23
Lack of appetite	.50	.91
Excessive appetite	.65	1.02
Digestion dysfunctions	.79	1.14
Alteration of sexuality	.80	1.07
Weakness during work activities	1.44	1.18

*Confirmatory Factor Analysis*

We ran a confirmatory factor analysis to test the emerged model from EFA of the Turkish version of METEO-Q. This analysis performed on the second subsample, which consisted of 303 participants by using LISREL 8.80.

**Table 3.** Comparison of the fit indices of the tested model

Model	$\chi^2$	df	$\chi^2 / df$	CFI	SRMR	RMSEA
Two-factor model	214.60	43	4.99	.96	.06	.11
Two-factor model with three covariance error	114.86	40	2.87	.98	.04	.08

We tested the model of METEO-Q, which indicating two-factor structure. The initial model exhibited poor model fit, as indicated by the following fit indices:  $\chi^2 = 214.60$ ,  $p = .00$ ; RMSEA= .11, SRMR= .056, CFI= .96,  $\chi^2/df= 4.99$ . The examination of modification indices' suggestions revealed some modifications that hold statistical and theoretical significance, aimed at improving the model fit. In accordance with the modification suggestion, we set the error term freely between

the following item pairs; item 6 and item 10; item 6 and item 11, and item 10 and item 11 (see figure 1). Finally, we achieved a better adjustment of this final two-factor model with three covariance error terms ( $\chi^2 = 114.86, p = .00$ ; RMSEA= .08, SRMR= .04, CFI= .98,  $\chi^2/df= 2.87$ ). As shown in Table 2, the fit indices of the model that setting covariance indicated a better fit.

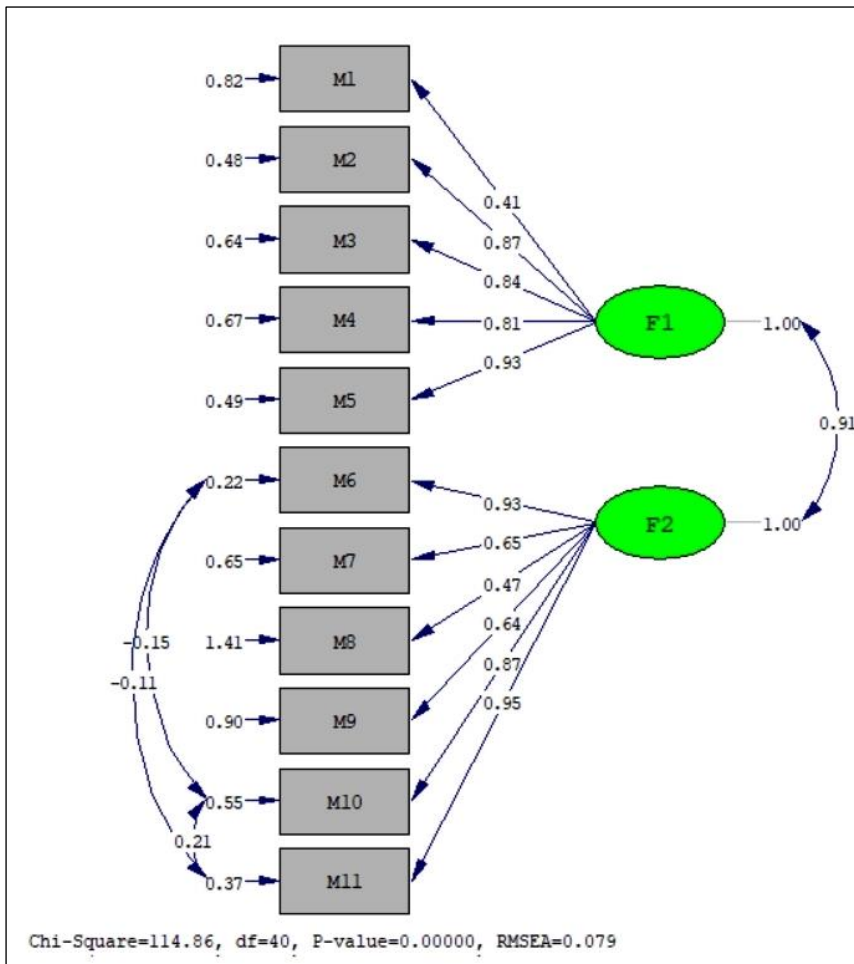

Figure 1.

### Reliability

We used internal consistency by computing Cronbach's Alpha scores for the total METEO-Q and subscales to examine the reliability of the total sample. Internal

consistency for the total scale score was .93, and internal consistency of the subscales was determined as .86 for meteorosensitivity and .88 for meteoropathy. We calculated the Cronbach alpha score as .95 for the structured checklist. The item-total correlation is presented in Table 1. Furthermore, we also conducted a test-retest reliability score with a sample size of 44. The test-retest reliability revealed that the total score of METEO-Q ( $r = .68, p < .001$ ), meteorosensitivity subscale ( $r = .56, p < .001$ ), meteoropathy subscale ( $r = .66, p < .001$ ), and the structured checklist ( $r = .75, p < .001$ ) had positive and significant reliability.

*Correlation with SPAQ*

As previous research claimed that alterations in weather changes may also trigger psychological disorders, specifically seasonal affective disorder (Cianconi et al., 2020), we calculated the Pearson correlation coefficient between the total score, subscales of METEO-Q, the structured checklist, and SPAQ on the total sample. As expected, we found a positive relationship between the total and subscales of METEO-Q, the structured checklist, and a positive relationship between SPAQ-Global seasonality and severity. The correlation coefficient between the variables is presented in Table 4.

**Table 4.** Correlation coefficients between METEO-Q and SPAQ

	1	2	3	4	5	6
1. METEO-Q Total		.939**	.957**	.771**	.730**	.565**
2. Meteorosensitivity			.798**	.679**	.671**	.475**
3. Meteoropathy				.775**	.710**	.561**
4. METEO-Q Checklist					.784**	.627**
5. SPAQ-Seasonality						.535**
6. SPAQ-severity of the symptoms						

\*\* . Correlation is significant at the 0.01 level (2-tailed).

*Subgroup Differences Analysis*

The independent samples *t*-test was carried out to measure the mean differences in gender in the total sample. There were significant differences between men and women in total METEO-Q ( $t_{(601)} = -7.938, p < .001$ ), meteorosensitivity ( $t_{(601)} = -6.512, p < .001$ ), meteoropathy ( $t_{(601)} = -8.340, p < .001$ ), and the structured checklist ( $t_{(601)} = -7.409, p < .001$ ). Women had significantly higher mean score than men. There was also significant mean difference in suicidality in total METEO-Q ( $t_{(601)} = -4.593, p < .001$ ), meteorosensitivity ( $t_{(601)} = -3.550, p < .001$ ), meteoropathy ( $t_{(601)} = -5.034, p < .001$ ), and the structured checklist ( $t_{(601)} = -6.216, p < .001$ ). In other words, participants who attempted suicide scored higher. Finally, we found a statistically significant differences in self-mutilation in total METEO-Q ( $t_{(601)} = -6.892, p < .001$ ),

meteorosensitivity ( $t_{(601)}=-6.119, p<.001$ ), meteoropathy ( $t_{(601)}=-6.846, p<.001$ ), and the structured checklist ( $t_{(601)}=-8.892, p<.001$ ).

## **Discussion**

The current study aimed to adapt and examine the psychometric properties of the METEO-Q Scale in the Turkish population. Besides, this study also aimed to eliminate some of the limitations of the original study by testing factor structure. We demonstrated that the Turkish version of METEO-Q had good psychometric properties when used with the Turkish population. As consistent with the original study of Mazza et al. (2012), the scale had a two-factor structure. As presented in the related literature, gender and some psychiatric conditions, such as suicide attempts and self-mutilation, were found to be associated with both the total and subscale scores on the scale.

Our first goal was tested by conducting exploratory factor analysis to test the construct validity of METEO-Q. The scale had two factors, and all items made statistically significant contributions to measuring meteoropathy. Mazza et al. (2012) did not examine construct validity in the development study. Instead, they tested the scale with classical item analysis, including the index of difficulty and the index of discrimination as the analysis indicators. However, factor analysis is the most common technique for construct validity in psychological measurement (Ellis, 2017). Factor analysis is a superior technique to classical item analysis for some reasons, such as comparing item intercorrelations with other items simultaneously and providing the factor numbers (Benson, 1978). Thus, we first applied exploratory factor analysis to examine construct validity. Our result demonstrated that the scale has two factors, and all items significantly contribute to the scale. The first five items have loaded factor one, meteorosensitivity, and the remaining six items have loaded factor two, which refers to meteoropathy, as in the original study by Mazza et al. (2012).

Our other goal was to verify the validity of the structure obtained from EFA by performing CFA. While the original research did not test the underlying factor structure, we examined the CFA model to find out the underlying factor structure with a different data set. According to CFA results, the two-factor model, which correlated with each other, showed a better fit to the data when setting the free error covariance. According to the results of the present study, meteoropathy and meteorosensitivity are associated with each other. In other words, these two are dependent subdimensions of METEO-Q (Mazza et al., 2012). In sum, METEO-Q has exhibited good construct validity.

We also expected that meteoropathy would be positively associated with seasonal affective disorder, gender, and some psychiatric conditions following the

previous research. As expected, the subdimensions of global seasonality and severity of SPAQ and METEO-Q were positively associated. Thus, we extended the original study's findings in light of this literature. Women had a higher score than men in meteoropathy and meteorosensitivity, as expected in the structured symptom checklist and in line with the study of Mazza et al. (2012). Furthermore, we found that people who attempted suicidal behavior got a higher score on the METEO-Q than those who did not. This finding presented evidence to support the idea that sensitivity to climatic and weather changes was associated with suicidal behaviors (Kim et al., 2004; di Nicola et al., 2020). Besides, some research claimed that weather conditions negatively affected aggressive behavior (Lickiewicz et al., 2020). Following the study of Lickiewicz et al. (2020) on self-mutilation behaviors as indicators of self-directed aggression, we demonstrated that persons who engaged in self-mutilating behaviors showed higher scores in METEO-Q. Our findings have expanded and supported the existing literature, indicating that individuals who suffer from psychiatric problems, including suicidal attempts and self-mutilation, may be more sensitive to weather conditions. Hence, our findings showed that METEO-Q reflected good criteria-related validity by considering the association with SPAQ, gender, and psychiatric conditions.

Regarding reliability analysis, we calculated Cronbach's Alpha scores, inter-item correlation, and test-retest reliability. The total score, two scale factors, and structured symptom checklist showed good internal consistency in line with the original study. In addition, test-retest correlation analysis also refers to adequate reliability scores. Hence, the scale proved to be a reliable measurement tool to assess meteoropathy.

Although the strength of the study was to expand the original study of METEO-Q, this study also addresses some limitations that are important to point out. First of all, the homogeneity of our sample is questionable since we selected our participants via convenience sampling. That means our sample is not representative of Turkish society, so we could not generalize the results. Another limitation is that we used only the general population via an online survey. Future studies should replicate the study with a clinical population such as bipolar disorder, as we know sensitivity to climatic variation is an important issue in some psychiatric conditions.

Despite the limitations, this study contributes to the related literature by extending the psychometric properties of the original study and its necessary implications for clinicians and researchers in psychiatry. Weather and climatic variation impact one's physical and psychological health (Balsamo et al., 1992; Mazza et al., 2012; Celic et al., 2019; Oniszczenko, 2020; Lickiewicz et al., 2020; Rzeszutek et al., 2020). Furthermore, the number of meteoropathic people who are extremely sensitive to weather and climatic variations is increasing (Lickiewicz et al., 2020). Thus, detecting meteoropathy and meteorosensitivity gains importance for clinical practice to consider the effects of weather and climatic variations on individuals' physical and psychological health. Hoxha and Zappacosta (2023) have

highlighted that awareness of meteoropathy plays a crucial role in developing approaches aimed at improving the quality of life for meteoropathic individuals. Examining psychometric properties, we suggest that the Turkish version of METEO-Q is a reliable and valid measurement tool for assessing meteoropathy.

### Authors' Notes

**Funding.** The authors received no funding for the research.

**Declarations of interest.** The authors declared that there are no potential conflicts of interest.

### References

- Balsamo, V., Sirtori, P. G., Miani Jr, A., Di Francesco, A., Franceschini, R., Mauro, F., Alberti, G. & Grassi, G. (1992). Meteoropathy: a syndrome continuously on the increase. *La Clinica Terapeutica*, 141(7), 3-8.
- Benson, I. G. (1978). A comparison of three types of item analysis in test development using classical and latent trait methods. *Dissertation Abstracts International Section A: Humanities and Social Sciences*, 39(1-A), 243–244.
- Čelić, I., Živanović, S., & Pavlović, N. (2019). The effects of weather conditions on the health of people living in urban and rural environments. *Економика пољопривреде*, 66(1), 63-76. <https://doi.org/10.5937/ekoPolj190163C>
- Cianconi, P., Betrò, S., & Janiri, L. (2020). The impact of climate change on mental health: a systematic descriptive review. *Frontiers in psychiatry*, 11, 74. <https://doi.org/10.3389/fpsy.2020.00074>
- Di Nicola, M., Mazza, M., Panaccione, I., Moccia, L., Giuseppin, G., Marano, G., Grandinetti, P., Camardese, G., De Berardis, D., Pompili, M., & Janiri, L. (2020). Sensitivity to climate and weather changes in euthymic bipolar subjects: association with suicide attempts. *Frontiers in psychiatry*, 11, 95. <https://doi.org/10.3389/fpsy.2020.00095>
- Ellis, J. L. (2017). Factor analysis and item analysis. *Applying Statistics in Behavioural Research*, 11-59.
- Hoxha, M., & Zappacosta, B. (2023). Meteoropathy: a review on the current state of knowledge. *Journal of Medicine and Life*, 16(6), 837-841. <https://doi.org/10.25122/jml-2023-0097>
- Jacobi, E., Richter, O., & Krüskemper, G. (1981). Simulated VLF-fields as a risk factor of thrombosis. *International Journal of Biometeorology*, 25(2), 133-142. <https://doi.org/10.1007/BF02184461>

- Janiri, L., Spinetti, G., Mazza, M., & Di Nicola, M. (2009). Meteoropathy A new disease. In G. N. Christodoulou, M. Jorge, & J. E. Mezzich (Eds.), *Advances in Psychiatry* (Vol. 3, pp. 45-52). BETA Medical Publishers.
- Kim, C. D., Lesage, A. D., Seguin, M., Chawky, N., Vanier, C., Lipp, O., & Turecki, G. (2004). Seasonal differences in psychopathology of male suicide completers. *Comprehensive Psychiatry*, *45*(5), 333-339. <https://doi.org/10.1016/j.comppsy.2004.06.007>
- Licanin, I., Fisekovic, S., & Babić, S. (2012). Admission rate of patients with most common psychiatric disorders in relation to seasons and climatic factors during 2010/2011. *Materia socio-medica*, *24*(2), 94-99. <https://doi.org/10.5455/msm.2012.24.94-99>
- Lickiewicz, J., Piotrowicz, K., Hughes, P. P., & Makara-Studzińska, M. (2020). Weather and aggressive behavior among patients in psychiatric hospitals—an exploratory study. *International journal of environmental research and public health*, *17*(23), 9121. <https://doi.org/10.3390/ijerph17239121>
- Loth, F. L., Liebensteiner, M. C., Giesinger, J. M., Giesinger, K., Bliem, H. R., & Holzner, B. (2018). What makes patients aware of their artificial knee joint?. *BMC Musculoskeletal Disorders*, *19*(1), 1-7. <https://doi.org/10.1186/s12891-017-1923-4>
- Mazza, M., Di Nicola, M., Catalano, V., Callea, A., Martinotti, G., Harnic, D., Bruschi, A., Battaglia, C., & Janiri, L. (2012). Description and validation of a questionnaire for the detection of meteoropathy and meteorosensitivity: the METEO-Q. *Comprehensive psychiatry*, *53*(1), 103-106. <https://doi.org/10.1016/j.comppsy.2011.02.002>
- Noyan, M. A., Elbi, H., & Korukoglu, S. (2000). Mevsimsel gidis degerlendirme formu (MGDF) Güvenilirlik arastirmasi/The Turkish version of Seasonal Pattern Assessment Questionnaire (SPAQ): A reliability study. *Anadolu Psikiyatri Dergisi*, *1*(2), 69.
- Oniszczenko, W. (2020). Affective Temperaments and Meteoropathy Among Women: A Cross-sectional Study. *PLoS One*, *15*(5), e0232725. <https://doi.org/10.1371/journal.pone.0232725>
- Reid, S., Towell, A. D., & Golding, J. F. (2000). Seasonality, social zeitgebers and mood variability in entrainment of mood: Implications for seasonal affective disorder. *Journal of affective disorders*, *59*(1), 47-54. [https://doi.org/10.1016/S0165-0327\(99\)00122-6](https://doi.org/10.1016/S0165-0327(99)00122-6)
- Rosenthal, N.E., Genhart, M.J., Sack, D.A., Skwerer, R.G. and Wehr, T.A. (1987) Seasonal affective disorder and its relevance for the understanding and treatment of bulimia. In Hudson, J.I. and Pope, H.G. (Eds.), *The Psychobiology of Bulimia*. American Psychiatric Press, Washington, DC, pp. 205–228.
- Ruszkiewicz, J. A., Tinkov, A. A., Skalny, A. V., Siokas, V., Dardiotis, E., Tsatsakis, A., Bowman, A., B., da Rocha J. B. T., & Aschner, M. (2019). Brain diseases

- in changing climate. *Environmental research*, 177, 108637. <https://doi.org/10.1016/j.envres.2019.108637>
- Rzeszutek, M., Oniszczenko, W., Zalewska, I., & Pięta, M. (2020). Personality profiles and meteoropathy intensity: A comparative study between young and older adults. *Plos one*, 15(11), e0241817. <https://doi.org/10.1371/journal.pone.0241817>
- Schermelleh-Engel, K., Moosbrugger, H., & Müller, H. (2003). Evaluating the fit of structural equation models: Tests of significance and descriptive goodness-of-fit measures. *Methods of psychological research online*, 8(2), 23-74.
- Schienze, A., Stark, R., & Vaitl, D. (1998). Biological effects of very low frequency (VLF) atmospheric in humans: a review. *Journal of Scientific Exploration*, 12(3), 455-468.
- Schienze, A., Stark, R., & Vaitl, D. (2001). Sferics provoke changes in EEG power. *International journal of neuroscience*, 107(1-2), 87-102. <https://doi.org/10.3109/00207450109149759>
- Vodolazhskaya, M. G., & Vodolazhskii, G. I. (2016). Gender differences in weather sensitivity of normal adult people detected in rheoencephalograms and electroencephalograms. *Human Physiology*, 42(7), 793-798. <https://doi.org/10.1134/S0362119716070203>



---

## LONELINESS AND MENTAL HEALTH DURING THE FIRST COVID-19 LOCKDOWN IN ROMANIA

---

A. Hopulele-Petri<sup>1,2\*</sup>, S.A. Matu<sup>3</sup>, O. Capatina<sup>4</sup>, M. Manea<sup>5</sup>

<sup>1</sup> Department of Psychiatry and Psychology, Faculty of Dental Medicine, “Carol Davila” University of Medicine and Pharmacy, Bucharest, Romania

<sup>2</sup> “Constantin Papilian” Emergency Military Hospital, Cluj-Napoca, Romania

<sup>3</sup> Department of Clinical Psychology and Psychotherapy, Babeş-Bolyai University

<sup>4</sup> Department of Psychiatry, Faculty of Medicine, “Iuliu Hatieganu” University of Medicine and Pharmacy, Cluj-Napoca, Romania

<sup>5</sup> “Prof. Dr. Alexandru Obregia” Clinical Hospital of Psychiatry, Bucharest, Romania

---

### Abstract

During the spring of 2020, Romania entered its first lockdown in response to the growing Covid-19 pandemic. The pandemic’s impact on mental health was thus superimposed on an already epidemic risk of loneliness in developed countries. The purpose of this article was thus to measure the impact of perceived social isolation during the national lockdown on emotional distress among the general population, while also considering potential risk or buffering factors like social media usage, and romantic relationships. Featuring a cross-sectional design, data was collected from 180 participants, aged 20 – 60 years using an online questionnaire which included the DASS-21 scale, the UCLA Loneliness Scale and the Intimate Relationships Scale. Our results indicated that loneliness significantly predicted depressive, anxious and stress symptoms even when correcting for gender and age. Distancing measures had no significant effect on couples, though differences in depression and loneliness were found between those with no partner, and those who described minimal impact of social distancing measures. Number of social media sites used predicted greater depressive and anxious symptoms, even when correcting for age and gender, whereas partner intimacy presented as a protective factor for loneliness. Given the many public, individual and dyadic factors involved in mental health during a pandemic, the implications for further studies are discussed.

**Keywords:** Loneliness; Covid-19; Mental health; Social Network Sites; Intimacy.

---

\* Correspondence concerning this article should be addressed to Andrei Hopulele-Petri, “C. Papilian” Emergency Military Hospital; Traian Mosoiu No. 22; Cluj-Napoca, Cluj, Romania.  
E-mail: andrei.hopulele@gmail.com

Following its emergence in December 2019, the SARS-CoV-2 virus rapidly spread throughout 2020, leading to an unprecedented health crisis in the modern world. Between February and May 2020, Romania had 13,512 confirmed cases and 803 deaths (World Health Organization, 2020). In response, the Romanian government instituted multiple preventive measures, from travel bans, school closures, bans on public gatherings, and finally, a military curfew (Dascalu, 2020). Even before the COVID-19 pandemic, loneliness had been described as an epidemic occurring in the developed world (Williams & Braun, 2019; Jeste et al., 2020), particularly in former Soviet countries (Yang & Victor, 2011). Our study explored the pivotal role of loneliness during the first wave of the pandemic in Romania, its relationship with social distancing and intimacy, and its effect on social media usage and psychological distress.

Psychological distress has been largely defined as a state of emotional suffering characterized by symptoms of depression and anxiety (Mirowsky & Ross, 2002). Most studies during the pandemic found females at higher risk for psychological distress than men (Beutel et al., 2021; Fernández et al., 2020; Li & Wang, 2020; Prout et al., 2020; Filindassi et al., 2022; Ausín et al., 2021), whereas age was found a negative predictor (Li & Wang, 2020; Prout et al., 2020; Naser et al., 2020; Ausín et al., 2021; Robillard et al., 2020). Pandemic restrictions meant that individuals had access to their social support suddenly restricted, which in turn can lead to more subjective distress (Wang et al., 2021). Indeed, during the pandemic social risk factors for psychological distress included living alone (Fancourt et al., 2021; Li & Wang, 2020, Guo et al., 2020), low social support (Elmer et al., 2020), low quality of social interactions (Wathelet et al., 2020) and worse relationships with family and friends (Robillard et al., 2020; Guo et al., 2020).

Loneliness has been defined as the subjective, aversive state that arises from the perceived discrepancy between one's actual and desired social relationships (Peplau & Perlman, 1982). An individual can experience loneliness even when surrounded by friends or family, as loneliness relates to the perceived quality rather than the quantity of one's relationships or time spent with others (Hawkey et al., 2003; Masi et al., 2011). Loneliness has been identified as a risk factor for somatic illness (e.g., Foti et al., 2020; Abdellaoui et al., 2019; Qualter et al., 2021), neurodegenerative syndromes (Buchman et al., 2010) and psychiatric disorders (for a review, see Hawkey & Cacioppo 2010). A study undertaken in Spain during the first year of the pandemic found that loneliness was one of the main predictors of psychological distress (González-Sanguino et al., 2022). A comparative analysis of adults before and during the COVID-19 pandemic revealed that while some risk factors were the same as in pre-pandemic times (e.g., women and individuals living alone), other groups presented a higher-than-usual risk (e.g., younger people) while others, usually not at risk, presented at risk (i.e., students) (Bu et al., 2020).

Intimate relationships allow for dyadic coping (Bodenmann, 2005), allowing partners to support each other during difficult situations (Gottlieb & Wagner, 1991).

During the pandemic, couples living apart from their partner reported loneliness levels similar to singles living alone (Hopf et al., 2022). For couples living together, relationship quality seemed negatively associated with psychological distress during the pandemic (Estlein et al., 2022), while loneliness seemed to mediate the relationship between the two (Charvat et al., 2023). One way of communicating romantic closeness is sexual intimacy, which involves the physical and emotional expression of feelings between partners (Theiss & Estlein, 2014). Studies during the first year of the COVID-19 pandemic found decreases in sexual functioning (Fuchs et al., 2020; Omar et al., 2021) frequency (Baran & Aykac, 2020; Li et al., 2020) and satisfaction (Omar et al., 2021), while sexuality was also negatively associated with psychological distress during the pandemic (Estlein et al., 2022).

The emergence during the last two decades of social network sites (SNS) has provided individuals with access to new channels through which to stay connected and engage with their peers. SNS can provide meaningful social resources during social distancing (Latikka et al., 2022) by facilitating social connection and inclusion (Morahan-Martin & Schumacher, 2003; Thomas et al., 2020) yet can also serve as risk factors for psychological distress (Geirdal et al., 2021; Hunt et al., 2018). During the pandemic, loneliness predicted both excessive social media use and anxiety (Boursier et al., 2020). Individuals experiencing loneliness can use social media to compensate for absent in-person relationships, though they do not necessarily receive the support they seek (O'Day & Heimberg, 2021). High-frequent SNS usage seems to be associated with higher levels of loneliness in younger adults (Bonsaken, 2020). During the pandemic, in young adults, SNS usage was associated with depressive, anxiety, and stress symptoms (Al-Dwaikat et al., 2020; Lin et al., 2020).

In the current study, we examined the relationship between loneliness and psychological distress during the COVID-19 lockdown in Romania in the spring of 2020. We also considered the impact of distancing measures, SNS usage, and the protective role of sexual intimacy for couples. Our study thus set upon the following hypotheses:

h1) Increased loneliness will predict increased psychological distress symptoms.

h2) SNS usage will predict psychological distress symptoms.

h3) Partner absence and greater impact of social distancing measures will predict higher levels of loneliness and psychological distress

h4) SNS will mediate the relationship between loneliness and psychological distress

h5) For couples, loneliness will mediate the relationship between sexual intimacy and psychological distress

## **Methods**

### *Study Design*

The study's target was represented by the general population of Romania during the first Romanian COVID-19 lockdown. Following a cross-sectional design, data was collected using Google Forms between April and May 2020. Due to the lockdown measures in place, snowball sampling was used to disseminate the questionnaire through social media. Participants could access the link through personal computers and smart devices like phones or tablets. Participation in the study was preceded by an online consent form, during which participants were instructed on the goals and methods of the study, as well as data storage. The survey employed conditional branching based on a single response item regarding the impact of social distancing. Though no time limit for completion was set, participants had to finish the questionnaire in one sitting. No incentives were offered. There was no randomization of items or scale order. Individual responses were timestamped. The digital questionnaire has been tested prior to publishing by the main author.

The study has been reviewed and approved by the Institutional Review Board of the Cluj-Napoca Military Hospital 'C. Papiian' (reference number 1855/11.05.2020) prior to publication.

### *Measures*

Social Network Sites (SNS) were measured using a single item Likert-scale, asking the participant how many SNSs they regularly use (e.g., Facebook, Instagram, Twitter), with answers ranging from 'one' to 'four and beyond' for a total of four possible answers.

The impact of social distancing on romantic relationships was measured using a single-item question. Participants had to answer whether the lockdown measures had affected the frequency with which they could meet their partner: (a) not at all, (b) partially affected, (c) strongly affected, or (d) if they had no romantic partner during the lockdown at all.

Psychological distress was conceptualized as depressive, anxiety, and stress symptoms and assessed via the DASS-21 scale (Lovibond & Lovibond, 1995). The DASS-21 contains 21 self-report items (7 items per subscale), including: "I couldn't seem to experience any positive feelings at all" (depression), "I experienced trembling (e.g., in the hands)" (anxiety), and "I tended to overreact to situations" (stress). Participants indicated the frequency with which they experienced each statement). Higher scores suggest a greater frequency of depressive, anxiety, and stress symptoms, whereas low scores suggest a lower frequency. Completion of the DASS-21 was mandatory for all participants. In our sample, the following internal reliability

coefficients and descriptive statistics were observed: depression ( $\alpha = .91$ ,  $M= 6.81$ ,  $SD =5.60$ ), anxiety ( $\alpha = .88$ ,  $M=4.63$ ,  $SD=4.7$ ), and stress ( $\alpha = .91$ ,  $M=8.05$ ,  $SD=5.29$ )

Loneliness was measured using the revised version of the University of California, Los Angeles Loneliness Scale (ULCA-L) (Russel et al., 1980). Modeled on the conceptualization of loneliness as, first and foremost, a subjective emotion, this self-reported scale uses twenty items representing Likert-type scales. The scale has repeatedly demonstrated good construct validity and reliability and has been extensively used on younger populations. Higher scores reflect higher perceived social isolation. Completion of the UCLA-L was mandatory for all participants. Reliability analysis of the scale in our sample revealed excellent results ( $\alpha =.93$ ,  $M=23.09$ ,  $SD=12.2$ ).

Sexual-emotional intimacy was measured using the Intimate Relationship Scale (IRS) (Hetherington & Soeken, 1990). This self-administered scale measured changes in intimacy and sexuality on three dimensions (personal, physical, and cognitive). The scale consists of 12 items adapted for the lockdown (i.e., “Since the lockdown, my desire for sexual intercourse is”) scored on a Likert scale (from 1 – ‘muchless’ to ‘5 – a lot more’). The final score thus represents changes in sexual intimacy, with lower scores representing reduced sexual intimacy and higher scores representing improved sexual intimacy following lockdown measures. Although initially developed for measuring post-partum changes in emotional and sexual intimacy between partners, the scale has also been used to measure changes in intimacy following miscarriage (Serrano & Lima, 2006), malignancies (Cleary, 2019), pregnancy (Cassis, 2020). In our sample, the scale presented excellent internal reliability ( $\alpha = .92$ ,  $M=35.80$ ,  $SD=7.84$ ).

*Participants*

The sample was composed of 180 responders who completed the online survey. Age ranged from 20 to 60 years old ( $M = 31.21$ ,  $SD = 7.76$ ). Most participants were female (70%), with most reporting a bachelor-level education or higher (85%) and describing themselves as employed (64%) or freelancers (13%). Regarding the involvement in home-office activities during the lockdown, responses were mostly balanced, with little over half (56%) reporting involvement in such. Demographic characteristics of our sample are summarized in Table 1.

**Table 1.** Demographic characteristics of the study sample

		<b>N=180</b>
<b>Gender</b>	Male	53 (29.4%)
	Female	127 (70.6%)
<b>Education</b>	Less than High school	1 (.6%)
	High school	26 (14.4%)
	Bachelor	116 (64.4%)
	Post-grad	37 (20.6%)

		N=180
<b>Professional status</b>	Unemployed	3 (1.7)
	Student	26 (14.4)
	Employed	116 (64%)
	Self-employed	24 (13.3%)
	(Missing)	11 (6.1%)
<b>Distancing impact</b>	No partner	51 (28.3)
	No separation	79 (43.9%)
	Partial separation	21 (11.7%)
	Important separation	28 (15.6)
	Missing	1 (0.6%)
<b>SNS usage</b>	1	40 (22.2%)
	2	79 (43.9)
	3	32 (17.8%)
	≥4	28 (15.6%)

*Statistical analysis*

Statistical analyses were performed using R v. 4.3.0 (R Core Team, 2021). Path analysis was conducted in a Structural Equation Modeling (SEM) framework using the lavaan package for R (Rosseel, 2012). Multiple imputations for the path analysis were conducted using the mice package (Van Buuren & Groothuis-Oudshoorn, 2011).

**Results**

*Loneliness and psychological distress.*

Linear regressions were used to test if loneliness predicts depressive, anxious, and stress-type symptoms, all measured with the DASS-21, while also controlling for age and gender. The overall model for depression was significant,  $R^2 = .52$ ,  $F(3, 175) = 63.13$ ,  $p < .001$ . Model coefficients (see Table 2) indicated that loneliness,  $b = .31$ ,  $SE = 0.02$ ,  $\beta = .68$ ,  $t(175) = 12.85$ ,  $p < .001$ , and age,  $b = -.11$ ,  $SE = 0.04$ ,  $\beta = -.15$ ,  $t(175) = -2.77$ ,  $p = .006$ . were both significant predictors. The overall model for anxiety was also significant,  $R^2 = .30$ ,  $F(3, 175) = 24.79$ ,  $p < .001$ . Model coefficients (see Table XX2) indicated that loneliness was the only significant predictor,  $b = .20$ ,  $SE = 0.02$ ,  $\beta = .51$ ,  $t(175) = 7.99$ ,  $p < .001$ . Finally, the overall model for stress symptoms was again significant,  $R^2 = .48$ ,  $F(3, 175) = 53.75$ ,  $p < .001$ . Individual coefficients (see Table 2), indicated that both loneliness,  $b = .28$ ,  $SE = 0.02$ ,  $\beta = .65$ ,  $t(175) = 11.69$ ,  $p < .001$ , and age  $b = -.10$ ,  $SE = 0.04$ ,  $\beta = -.14$ ,  $t(175) = -2.53$ ,  $p < .001$ , were significant predictors of stress symptoms.

**Table 2.** Regression table for loneliness, age, and gender on depressive, anxious, and stress symptoms

Parameter	<i>b</i>	95% CI ( <i>b</i> )	<i>T</i>	<i>df</i>	<i>p</i>	$\beta$
<i>Depression scores regressed on loneliness, gender, and age.</i>						
(Intercept)	2.82	[-0.46, 6.09]	1.70	175	.091	0.00
<b>Loneliness</b>	<b>0.31</b>	<b>[0.26, 0.36]</b>	<b>12.85</b>	<b>175</b>	<b>&lt; .001***</b>	<b>0.68</b>
Gender	0.07	[-1.20, 1.34]	0.11	175	.914	0.01
<b>Age</b>	<b>-0.11</b>	<b>[-0.18, -0.03]</b>	<b>-2.77</b>	<b>175</b>	<b>.006**</b>	<b>-0.15</b>
<i>Anxiety scores regressed on loneliness, gender, and age.</i>						
(Intercept)	2.84	[-0.49, 6.18]	1.68	175	.094	0.00
<b>Loneliness</b>	<b>0.20</b>	<b>[0.15, 0.25]</b>	<b>7.99</b>	<b>175</b>	<b>&lt; .001***</b>	<b>0.51</b>
Gender	-0.86	[-2.15, 0.43]	-1.31	175	.190	-0.08
Age	2.84	[-0.49, 6.18]	1.68	175	.094	0.00
<i>Stress scores regressed on loneliness, gender, and age.</i>						
(Intercept)	5.77	[2.55, 9.00]	3.53	175	.001***	0.00
<b>Loneliness</b>	<b>0.28</b>	<b>[0.23, 0.33]</b>	<b>11.68</b>	<b>175</b>	<b>&lt; .001***</b>	<b>0.68</b>
Gender	-0.92	[-2.17, 0.33]	-1.46	175	.147	0.01
<b>Age</b>	<b>-0.10</b>	<b>[-0.17, -0.02]</b>	<b>-2.53</b>	<b>175</b>	<b>.012*</b>	<b>-0.15</b>

Note. *b* represents unstandardized regression weights.  $\beta$  indicates the standardized regression weights. *LL* and *UL* indicate the lower and upper limits of a confidence interval, respectively.

\* indicates  $p < .05$ . \*\* indicates  $p < .01$ , \*\*\* indicates  $p < .001$ .

### *Online social network usage and psychological distress*

We conducted a similar analysis using social media use as the predictor of interest while alsocontrolling for demographics. The overall model for depression was significant,  $R^2 = .09$ ,  $F(3, 175) = 5.99$ ,  $p < .001$ . Model coefficients (see Table XX3) indicated that social media use,  $b = .95$ ,  $SE = 0.42$ ,  $\beta = .17$ ,  $t(175) = 2.26$ ,  $p = .025$ , and age,  $b = -.15$ ,  $SE = 0.05$ ,  $\beta = -.21$ ,  $t(175) = -2.97$ ,  $p = .003$ , both predicted depression. For anxiety, the overall model was significant,  $R^2 = .10$ ,  $F(3, 175) = 6.18$ ,  $p < .001$ , but model coefficients (Table 3) indicated that social media use was theonly significant predictor,  $b = 1.14$ ,  $SE = 0.35$ ,  $\beta = .24$ ,  $t(175) = 3.22$ ,  $p = .002$ . For stress symptoms, the model was also significant,  $R^2 = .09$ ,  $F(3, 175) = 5.71$ ,  $p < .001$ , but model coefficients (Table 3) indicated that age was the only significant predictor,  $b = -.15$ ,  $SE = 0.05$ ,  $\beta = -.21$ ,  $t(175) = -2.90$ ,  $p = .004$ .

**Table 3.** DASS-21 scores regressed on social media use, gender, and age

Parameter	<i>b</i>	95% CI ( <i>b</i> )	<i>t</i>	<i>df</i>	<i>p</i>	$\beta$	
<i>Depression</i>							
(Intercept)	9.99	[5.21, 14.78]	4.13	175	< .001***	0.00	
<b>Social media usage</b>	<b>0.95</b>	<b>[0.12, 1.79]</b>	<b>2.26</b>	<b>175</b>	<b>.025*</b>	<b>0.68</b>	
Gender	-0.33	[-2.07, 1.42]	-0.37	175	.712	0.01	
<b>Age</b>	<b>-0.16</b>	<b>[-0.26, -0.05]</b>	<b>-2.97</b>	<b>175</b>	<b>.003**</b>	<b>-0.15</b>	
<i>Anxiety</i>							
Parameter	<i>b</i>	95% CI ( <i>b</i> )	<i>t</i>	<i>df</i>	<i>p</i>	$\beta$	
(Intercept)	5.64	[1.62, 9.66]	2.77	175	.006**	0.00	
<b>Social media usage</b>	<b>1.14</b>	<b>[0.44, 1.84]</b>	<b>3.22</b>	<b>175</b>	<b>.002**</b>	<b>0.24</b>	
Gender	-1.06	[-2.52, 0.41]	-1.42	175	.156	-0.10	
Age	-0.07	[-0.16, 0.02]	-1.60	175	.112	-0.12	
<i>Stress Symptoms</i>							
Parameter	Fit	<i>b</i>	95% CI ( <i>b</i> )	<i>T</i>	<i>df</i>	<i>p</i>	$\beta$
(Intercept)		12.74	[8.21, 17.28]	5.55	175	< .001***	0.00
Social media usage		0.68	[-0.11, 1.47]	1.71	175	.089	0.13
Gender		-1.29	[-2.94, 0.36]	-1.55	175	.124	-0.11
<b>Age</b>		<b>-0.15</b>	<b>[-0.25, -0.05]</b>	<b>-2.90</b>	<b>175</b>	<b>.004**</b>	<b>-0.21</b>

Note. *b* represents unstandardized regression weights.  $\beta$  indicates the standardized regression weights. *LL* and *UL* indicate the lower and upper limits of a confidence interval, respectively.

\* indicates  $p < .05$ . \*\* indicates  $p < .01$ , \*\*\* indicates  $p < .001$ .

### Differences in psychological distress and loneliness between levels of social distancing

Multifactorial analysis of covariance (ANCOVA) was performed to compare the effect of distancing on loneliness and psychological distress. Gender was also introduced in the model as a factor, and age as a continuous covariate. Only main effects were introduced in the model, without interaction terms. Significant main effects were followed by pairwise comparisons of estimated marginal means from the model, using Bonferroni correction for multiple comparisons.

The model for depression indicated a significant effect for distancing,  $F(3, 173) = 5.29, p = .001, \eta_p^2 = 0.08$ , and for age,  $F(1, 173) = 7.67, p = .006, \eta_p^2 = 0.04$ . The fixed effect for age was negative,  $b = -.15, SE = 0.05$ , suggesting that age had a negative effect on depression. The only significant difference in the level of distancing emerged between those who did not have a partner ( $M = 8.42, SE = .78$ ) and those who reported that distancing had not affected their relationship with their partner ( $M = 5.34, SE = .63$ ),  $t(173) = 3.14, p = .012$ . The marginal means across levels of distancing impact are plotted in Figure 1. The model for anxiety indicated no significant effects.

The model for stress responses indicated a significant effect of age,  $F(3, 173) = 8.41$ ,  $p = .004$ ,  $\eta_p^2 = 0.05$ , while the fixed effect for age was once again negative,  $b = -.15$ ,  $SE = 0.05$ . Finally, for loneliness, we found a significant effect of distancing impact,  $F(3, 173) = 4.36$ ,  $p = .005$ ,  $\eta_p^2 = 0.07$ . Adjusted pairwise comparisons indicated a significant difference between those reporting that they did not have a partner ( $M = 26.44$ ,  $SE = 2.75$ ) and those that were not affected by the social distancing measures ( $M = 19.91$ ,  $SE = 1.40$ ),  $t(173) = 2.98$ ,  $p = .020$  (see Figure 1).

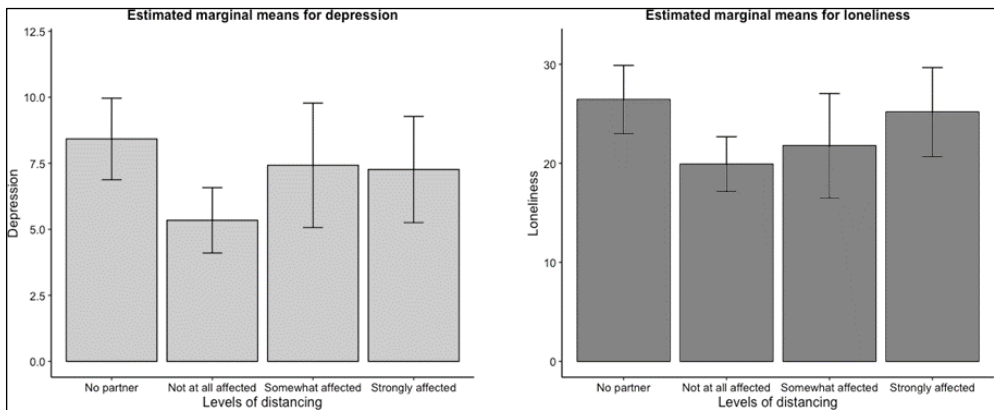

**Figure 1.** Depression (A) and loneliness (B) across levels of distancing.

*Note.* Error bars represent 95% confidence intervals of the means.

### *Path-analysis for indirect effects*

To test our hypotheses about the indirect effects that loneliness might have on emotional symptoms via social media usage, we conducted a path analysis using an SEM framework, with maximum likelihood estimation of model parameters and bias-corrected bootstrap confidence interval of the indirect effects, computed on 5000 resamples. The model we tested is presented in Figure 2. Our model was just identified, so model fit is not of interest for this model. The results suggested a direct effect of loneliness on all other variables: depression,  $b = .32$ ,  $SE = 0.02$ ,  $\beta = .69$ ,  $p < .001$ , anxiety,  $b = .19$ ,  $SE = 0.02$ ,  $\beta = .49$ ,  $p < .001$ , stress,  $b = .29$ ,  $SE = 0.02$ ,  $\beta = .66$ ,  $p < .001$ , and social media use,  $b = .02$ ,  $SE = 0.01$ ,  $\beta = .21$ ,  $p = .004$ . Social media usage had a significant effect only on anxiety,  $b = .78$ ,  $SE = 0.31$ ,  $\beta = .16$ ,  $p = .011$ . The indirect effect of loneliness on anxiety was significant,  $b = .013$ , 95%CI [.003, .034],  $\beta = .034$  (all variables standardized), but the indirect effect on depression,  $b = .007$ , 95%CI [-0.002, .033],  $\beta = .015$ , and stress,  $b = .003$ , 95%CI [-0.005, .019],  $\beta = .008$ , were not.

A final set of hypotheses that we tested were related to the effects of intimacy on loneliness and indirectly on psychological distress through loneliness and social media use. To test these relationships, we conducted a second path analysis, like the previous one, in which changes in intimacy acted as a predictor of loneliness and expressed its effects on all other variables through loneliness. Although this model is a direct extension of the previous one, we conducted a separate analysis with a different estimation approach to account for the missing data on the intimacy variable. To overcome this issue, we imputed 50 datasets based on all other variables, including demographics, using the mice package. We then ran our SEM model on these datasets using maximum likelihood estimation and pooled the coefficients and fit indices. To compute the confidence interval for product coefficients describing indirect effects, we used a Monte Carlo estimation. The model (see Figure 3) had excellent fit,  $\chi^2(4) = 4.28, p = .369, CFI = .99, RMSEA = .02, 95\% CI [.00, .116], SRMR = .046$ . The standardized direct paths are presented in Figure 3.

The direct paths from loneliness and social media on psychological distress are almost identical to those from the previous model. The path from intimacy to loneliness was significant,  $b = -.55, SE = 0.11, \beta = -.35, p < .001$ . The indirect effects of intimacy, through loneliness, on depression,  $b = -.17, 95\% CI [-.25, -.10], \beta = -.24$ , anxiety,  $b = -.11, 95\% CI [-.16, -.06], \beta = -.17$ , and stress,  $b = -.16, 95\% CI [-.23, -.09], \beta = -.23$ , were all significant. Also, the effect through loneliness and social media use on anxiety,  $b = -.007, 95\% CI [-.018, -.001], \beta = -.012$ , was also significant. The indirect effects of intimacy on depression and stress through the loneliness-social media link were not.

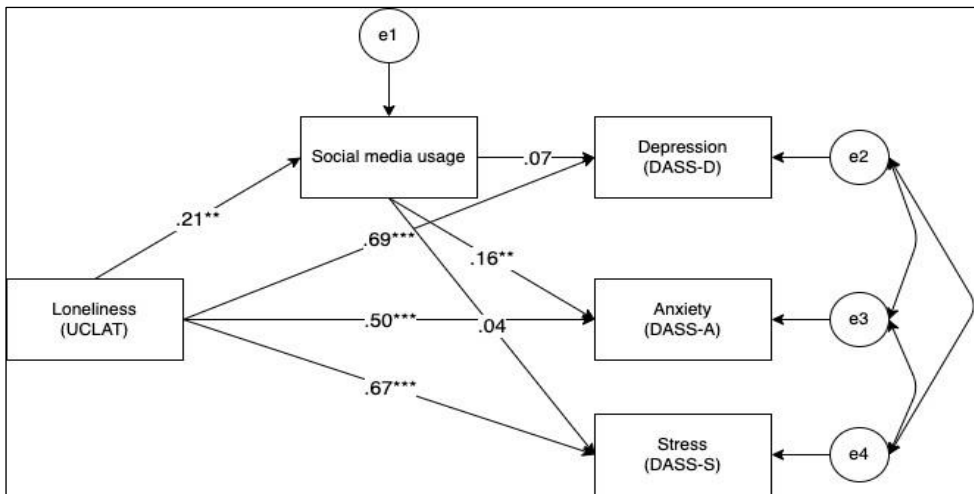

**Figure 2.** Path model for the indirect effect of loneliness on psychological distress.

Note. Values indicate standardized coefficients. \* indicates  $p < .05$ . \*\* indicates  $p < .01$ , \*\*\* indicates  $p < .001$ .

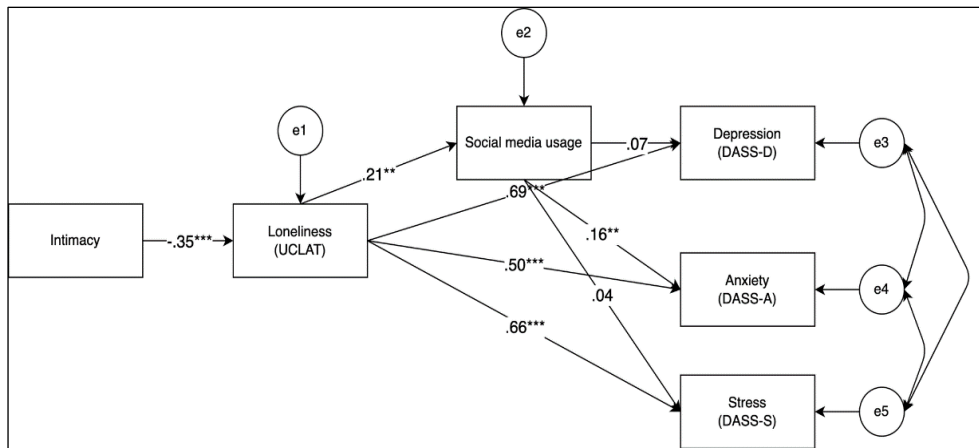

**Figure 3.** Path model for the indirect effect of intimacy on psychological distress.

Note. Values indicate standardized coefficients. \* indicates  $p < .05$ . \*\* indicates  $p < .01$ , \*\*\* indicates  $p < .001$ .

## Discussion

Our study's main goal was to evaluate the relationship between loneliness and psychological distress symptoms during the COVID-19 pandemic while also considering the impact of SNS usage and sexual intimacy. These predictive relationships were tested using linear regression models, analysis of covariance, and finally, within a structural equation modeling framework, measuring both intra-model relationships and inter-model ones.

First, our initial regression analysis indicated that loneliness has a predictive value on depression, anxiety, and stress symptoms even when correcting for age and gender, confirming our first hypothesis that loneliness would predict psychological distress. Our results align with prior research using the same scale that demonstrated significant correlations between loneliness and psychological distress (Tan et al., 2020; Panicker & Sachdev, 2014; Barroso et al., 2021). In the regression models for depression and stress, age presented a minimal yet statistically significant negative predictive value, in line with other studies that found younger adults at higher risk for mental health symptoms during the pandemic. distress (Li & Wang 2020; Prout et al., 2020; Naser et al., 2020; Ausín et al., 2021; Robillard et al., 2020). While most studies report female gender as a risk factor for psychological distress during the Covid-19 pandemic (Kolakowsky-Hayner et al., 2022; Bu et al., 2020; González-Sanguino et al., 2021), none of the regression models reported any effect of gender, on either loneliness or psychological distress symptoms. The relationship between

gender and loneliness is still being debated (Rokach, 2018), with some authors suggesting women are more likely to report symptoms of loneliness than men (Victor & Yang, 2012). Though similar results have been reported by some previous studies (Tan et al., 2020), one cannot exclude either the asymmetrical gender distribution in our sample or selection bias when interpreting the lack of a significant effect for gender in our sample.

Our second set of regression analyses set out to explore the predictive value of SNS usage on psychological distress, testing our second hypothesis. Regression analysis revealed that higher numbers of social networking sites used predicted depressive and anxious symptoms even when adjusting for age and gender, while age was found to be significant only in the depression and stress models. This is in line with prior research that linked psychological distress to social media addiction (Huang et al., 2023) and depressive symptoms to time spent and intensity of SNS usage (Hunt et al., 2018; Cunningham et al., 2021), including during the pandemic (Geirdal et al., 2021). Interpretation is limited by the quantitative approach used in our study, as prior research has demonstrated specific SNS usage patterns are more likely to predict depressive and anxious symptoms (O'Day & Heimberg, 2021), while other metrics like number of Facebook friends have been linked to decreased loneliness (Phu & Gow, 2009).

Lockdown measures affected everyone: couples living together experienced more time together, those living separately had fewer opportunities to interact, and individuals without a partner would spend more time alone at home. Our third hypothesis predicted that greater separation would yield more psychological distress and loneliness, while individuals lacking a partner would be the most affected. Statistical analysis revealed mixed results, with the only significant difference between couples who reported no impact of social distancing measures and individuals without a partner, and only for depressive symptoms and loneliness. Social distancing measures, though presenting more distress the more separated from their partner (see Figure 1), failed to produce statistically significant results. During the pandemic, concerns regarding the pandemic affected psychological well-being, though this effect was mediated through dyadic coping for couples (Donato et al., 2021). Though negative dyadic coping can exacerbate the effects of stress on mood (Bar-Kalifa et al., 2022), our results align with those that found individuals with no partner at greater risk for loneliness during the pandemic (Bu et al., 2020). Individuals experiencing both objective and subjective social isolation, who are denied social coping mechanisms and absent dyadic coping, can thus be at increased risk of depression (Cacioppo & Cacioppo, 2018).

Finally, our two SEM models revealed significant direct and indirect effects between all variables considered. Our first model (Figure 2) revealed important connections between loneliness and depression, stress, and anxiety symptoms. Though statistically significant in our regression models, in our first SEM model, SNS predicted only anxiety symptoms at a significant threshold. Regarding our

fourth hypothesis, the indirect path from loneliness through SNS usage to anxiety symptoms was also significant, possibly reflecting an inefficient support-seeking behavior aimed at reducing perceived social isolation through social media usage (Cauberghe et al., 2021). Our second SEM model (Figure 3) revealed an important protective role for sexual intimacy on perceived isolation, with indirect pathways through the latter on all three dimensions of psychological distress, confirming our fifth hypothesis.

The COVID-19 pandemic and its subsequent lockdown measures only further emphasized the role of SNS in disseminating information more efficiently than traditional media (Merchant & Lurie, 2020). During the pandemic, more people have become dependent on the use of social media, risking an increase in its deleterious effects on mental health (Garfin et al., 2020). Reports from prior public health incidents have noted that the intensity of the stress response to a first disaster augmented the relationship between SNS usage and worry during subsequent public health concerns (Thompson et al. 2017), with similar amplification effects of the disaster stressor found for Covid-10 (Zhao & Zhou, 2020). This is congruent with the ‘Differential Susceptibility to Media Effects Model’ (or DSMM) (Valkenburg & Peter, 2013), in which social media exposure and health outcomes operate via a feedback loop. Even before the pandemic, young adults were more likely to use SNS for disaster-related coverage (Jones et al., 2016). Thus, trait-like susceptibility to problematic SNS usage can be exacerbated by public disasters (Di Blasi et al., 2022), leading to more negative affective, anxiety, and stress (Chao et al., 2020; Garfin et al., 2020; Holman et al., 2014).

The external stressor presented by the pandemic might also have impacted dyadic relationships where one or both members presented enduring vulnerabilities (Pietromonaco & Overall, 2020). When both presence and the quality of the romantic relationship were taken into account, it was not the relationship per se, but its quality that presented as a protective factor for mental health during the pandemic (Pieh et al., 2020), and relationship quality has been repeatedly found as a predictor of mental health (Panzeri et al., 2020; Goodwin et al., 2020). The vulnerability-stress-adaptation model of marriage (Karney & Bradbury, 1995) posits that marital quality can impact the couple’s adaptive process to stressful events. This, in turn, lowers partners’ responsiveness and resilience (Pietromonaco & Overall, 2020). COVID-19 lockdowns and stay-at-home orders drastically restricted the breadth of socializing activities one could engage in, thus forcing those in relationships to rely more on their partner for their social and emotional needs and those single without any compensatory mechanism.

The COVID-19 pandemic has revealed how vulnerable the modern, interconnected world is to both an infectious and an informational pandemic. Even before the pandemic, former Soviet countries have been at risk for loneliness, which, when turning chronic, can lead to a host of mental health symptoms and disorders. Loneliness should not be seen as either a symptom of depression or an inevitability

of the modern world. Clinicians and therapists should consider both state and trait loneliness in clinical and sub-clinical individuals. State loneliness can turn chronic, leading to somatic and psychological issues in those healthy and worse recoveries in those with preexisting mental disorders. Couples' therapists should focus on loneliness as a marker of deficient intimacy and a mediator between it and perceived distress in a relationship. Therapists focusing on social media misuse should also consider how perceived social isolation can lead to increased SNS usage as a compensatory, yet ineffective, strategy.

Further research is warranted to explore not just loneliness as an individual experience but also an interpersonal one. Future studies should also consider attachment styles when researching loneliness and how those affect dyadic coping during stressful situations. Sociological research should also consider why loneliness is on an incline in parts of the world more connected than ever. Finally, policymakers should consider both the short-term effects of loneliness, such as during the pandemic and its long-term effect on mental and somatic health.

### *Limitations*

This present study has several limitations that are worth noting. There are significant demographic characteristics of the sample that limit extrapolating the results to the general population, such as the primarily female distribution, as well as the predominantly college-level education in our sample. This can be attributed to the sampling procedure employed and could explain the lack of a significant impact on gender since the majority of studies found women at higher risk for psychological distress and loneliness during the pandemic. Similarly, low education was also a risk factor for loneliness (Bu et al., 2020) and depression (Ustun, 2021) during the COVID-19 pandemic, again limiting the generalization of our results to the population of Romania as a whole.

Another limitation is the purely quantitative measurement of SNS, which prevented the capture of qualitative variables. The impact of SNS usage can vary depending on site type (i.e., text-based or image-based) and usage type (i.e., active use versus passive use) (Masciantonio et al., 2021). Finally, our research was cross-sectional, which always limits the reliability of any casual inferences drawn from the data and is subject to sampling bias because of the snowball sampling method.

Despite these limitations, the strengths of the present study need to be equally disclosed. First, to the best of our knowledge, our study is among the first to measure loneliness in Romania during the COVID-19 pandemic. Second, it is also among the first to qualitatively measure how changes in intimacy after lockdown measures affected psychological distress. Second, our study also measured how social distancing affected loneliness and its impact on psychological distress through depressive symptoms. Finally, the structural equation model approach is among the best-fitted techniques to be used in the context of cross-sectional design with interwoven variables.

### Conclusions

Our study found that perceived social isolation significantly affected all three dimensions of psychological distress, even when accounting for age and gender, as did the number of social networking sites used. Lockdown distancing measures seemed to impact psychological distress, as a significant difference in loneliness and depression was found between those who reported no impact of distancing measures and those without a partner during the lockdown. Social network site usage also mediated between loneliness and anxiety symptoms alone, possibly reflecting an inefficient coping mechanism, while romantic intimacy significantly reduced perceived social isolation during the COVID-19 lockdown.

### Authors' Notes

**Funding.** We have no financial support to declare.

**Declarations of Interest.** We have no conflicts of interest to disclose.

### References

- Abdellaoui, A., Sanchez-Roige, S., Sealock, J., Treur, J. L., Dennis, J., Fontanillas, P., ... & Boomsma, D. I. (2019). Phenome-wide investigation of health outcomes associated with genetic predisposition to loneliness. *Human molecular genetics*, 28(22), 3853-3865.
- Al-Dwaikat, T. N., Aldalaykeh, M., & Rababa, M. (2020). The relationship between social networking sites usage and psychological distress among undergraduate students during COVID-19 lockdown. *Heliyon*, 6(12).
- Ausín, B., González-Sanguino, C., Castellanos, M. Á., & Muñoz, M. (2021). Gender-related differences in the psychological impact of confinement as a consequence of COVID-19 in Spain. *Journal of Gender Studies*, 30(1), 29-38.
- Baran, O., & Aykac, A. (2021). The effect of fear of covid-19 transmission on male sexual behaviour: A cross-sectional survey study. *International Journal of Clinical Practice*, 75(4), e13889.
- Bar-Kalifa, E., Randall, A. K., & Perelman, Y. (2022). Daily dyadic coping during COVID-19 among Israeli couples. *Emotion*, 22(8), 1713.
- Barroso, S. M., Ferreira, H. G., & Araujo, F. C. (2021). Brazilian Loneliness Scale: evidence of validity based on relations to depression, anxiety and stress. *Psico-USF*, 26, 559-570.
- Beutel, M. E., Hettich, N., Ernst, M., Schmutzer, G., Tibubos, A. N., & Braehler, E. (2021). Mental health and loneliness in the German general population during

- the COVID-19 pandemic compared to a representative pre-pandemic assessment. *Scientific reports*, *11*(1), 1-9.
- Bodenmann, G. (2005). Dyadic coping and its significance for marital functioning. In Revenson T.A., Kayser, K. & Bodenmann G. (Eds.), *Couples coping with stress: Emerging perspectives on dyadic coping* (pp. 33–49). Washington, DC: American Psychological Association. 10.1037/11031-002
- Bonsaksen, T., Ruffolo, M., Leung, J., Price, D., Thygesen, H., Schoultz, M., & Geirdal, A. Ø. (2021). Loneliness and its association with social media use during the COVID-19 outbreak. *Social Media+ Society*, *7*(3), 20563051211033821.
- Boursier, V., Gioia, F., Musetti, A., & Schimmenti, A. (2020). Facing loneliness and anxiety during the COVID-19 isolation: the role of excessive social media use in a sample of Italian adults. *Frontiers in psychiatry*, *11*, 586222.
- Bu, F., Steptoe, A., & Fancourt, D. (2020). Loneliness during a strict lockdown: Trajectories and predictors during the COVID-19 pandemic in 38,217 United Kingdom adults. *Social Science & Medicine*, *265*, 113521.
- Buchman, A. S., Boyle, P. A., Wilson, R. S., James, B. D., Leurgans, S. E., Arnold, S. E., & Bennett, D. A. (2010). Loneliness and the rate of motor decline in old age: the rush memory and aging project, a community-based cohort study. *BMC geriatrics*, *10*, 1-8.
- Cacioppo, J. T., & Cacioppo, S. (2018). Loneliness in the modern age: An evolutionary theory of loneliness (ETL). In *Advances in experimental social psychology* (Vol. 58, pp. 127-197). Academic press.
- Cassis, C. (2020). *Female sexual functioning and pregnancy* (Doctoral dissertation, University of East Anglia).
- Cauberghe, V., Van Wesenbeeck, I., De Jans, S., Hudders, L., & Ponnet, K. (2021). How adolescents use social media to cope with feelings of loneliness and anxiety during COVID-19 lockdown. *Cyberpsychology, Behavior, and Social Networking*, *24*(4), 250-257.
- Chao, M., Xue, D., Liu, T., Yang, H., & Hall, B. J. (2020). Media use and acute psychological outcomes during COVID-19 outbreak in China. *Journal of anxiety disorders*, *74*, 102248.
- Charvat, E. J., Ogan, M., Kanter, J. B., Monk, J. K., & Proulx, C. (2023). Romantic relationship quality during the COVID-19 pandemic: The longitudinal associations with relationship loneliness and depression. *Social and Personality Psychology Compass*, e12823.
- Cleary, V. (2011). Sexuality in Irish women with gynecologic cancer. *Sexual health, gynecologic cancer, gynecologic malignancies Number 2/March 2011*, *38*(2), E87-E96.
- Cunningham, S., Hudson, C. C., & Harkness, K. (2021). Social media and depression symptoms: a meta-analysis. *Research on child and adolescent psychopathology*, *49*, 241-253.

- Dascalu, S. (2020). The successes and failures of the initial COVID-19 pandemic response in Romania. *Frontiers in Public Health*, 8, 344.
- Di Blasi, M., Salerno, L., Albano, G., Caci, B., Esposito, G., Salcuni, S., ... & Coco, G. L. (2022). A three-wave panel study on longitudinal relations between problematic social media use and psychological distress during the COVID-19 pandemic. *Addictive Behaviors*, 134, 107430.
- Donato, S., Parise, M., Pagani, A. F., Lanz, M., Regalia, C., Rosnati, R., & Iafrate, R. (2021). Together against COVID-19 concerns: The role of the dyadic coping process for partners' psychological well-being during the pandemic. *Frontiers in psychology*, 11, 578395.
- Elmer, T., Mepham, K., & Stadtfeld, C. (2020). Students under lockdown: Comparisons of students' social networks and mental health before and during the COVID-19 crisis in Switzerland. *Plos one*, 15(7), e0236337.
- Estlein, R., Gewirtz-Meydan, A., & Opuda, E. (2022). Love in the time of COVID-19: A systematic mapping review of empirical research on romantic relationships one year into the COVID-19 pandemic. *Family process*, 61(3), 1208-1228.
- Fancourt, D., Steptoe, A., & Bu, F. (2021). Trajectories of anxiety and depressive symptoms during enforced isolation due to COVID-19 in England: a longitudinal observational study. *The Lancet Psychiatry*, 8(2), 141-149.
- Fernández, R. S., Crivelli, L., Guimet, N. M., Allegri, R. F., & Pedreira, M. E. (2020). Psychological distress associated with COVID-19 quarantine: Latent profile analysis, outcome prediction and mediation analysis. *Journal of affective disorders*, 277, 75-84.
- Filindassi, V., Pedrini, C., Sabadini, C., Duradoni, M., & Guazzini, A. (2022). Impact of COVID-19 first wave on psychological and psychosocial dimensions: a systematic review. *Covid*, 2(3), 273-340.
- Foti, S. A., Khambaty, T., Birnbaum-Weitzman, O., Arguelles, W., Penedo, F., Espinoza Giacinto, R. A., ... & Llabre, M. M. (2020). Loneliness, cardiovascular disease, and diabetes prevalence in the hispanic community health study/study of latinos sociocultural ancillary study. *Journal of immigrant and minority health*, 22, 345-352.
- Fuchs, A., Matonóg, A., Pilarska, J., Sieradzka, P., Szul, M., Czuba, B., & Drosdzol-Cop, A. (2020). The impact of COVID-19 on female sexual health. *International journal of environmental research and public health*, 17(19), 7152.
- Garfin, D. R., Silver, R. C., & Holman, E. A. (2020). The novel coronavirus (COVID-2019) outbreak: Amplification of public health consequences by media exposure. *Health psychology*, 39(5), 355.
- Geirdal, A. Ø., Ruffolo, M., Leung, J., Thygesen, H., Price, D., Bonsaksen, T., & Schoultz, M. (2021). Mental health, quality of life, wellbeing, loneliness and use of social media in a time of social distancing during the COVID-19

- outbreak. A cross-country comparative study. *Journal of Mental Health*, 30(2), 148-155.
- González-Sanguino, C., Ausín, B., Castellanos, M. Á., Saiz, J., López-Gómez, A., Ugidos, C., & Muñoz, M. (2020). Mental health consequences during the initial stage of the 2020 Coronavirus pandemic (COVID-19) in Spain. *Brain, behavior, and immunity*, 87, 172-176.
- Goodwin, R., Hou, W. K., Sun, S., & Ben-Ezra, M. (2020). Quarantine, distress and interpersonal relationships during COVID- 19. *General Psychiatry*, 33, 1– 5. <https://doi.org/10.1136/gpsyc h-2020-100385>
- Gottlieb, B. H., & Wagner, F. (1991). Stress and support processes in close relationships. In *The social context of coping* (pp. 165-188). Boston, MA: Springer US.
- Guo, Y., Cheng, C., Zeng, Y. U., Li, Y., Zhu, M., Yang, W., ... & Wu, S. (2020). Mental health disorders and associated risk factors in quarantined adults during the COVID-19 outbreak in China: cross-sectional study. *Journal of medical Internet research*, 22(8), e20328.
- Hawkey, L. C., & Cacioppo, J. T. (2010). Loneliness matters: A theoretical and empirical review of consequences and mechanisms. *Annals of behavioral medicine*, 40(2), 218-227.
- Hawkey, L. C., Burleson, M. H., Berntson, G. G., & Cacioppo, J. T. (2003). Loneliness in everyday life: cardiovascular activity, psychosocial context, and health behaviors. *Journal of personality and social psychology*, 85(1), 105.
- Hetherington, S. E., & Soeken, K. L. (1990). Measuring changes in intimacy and sexuality: A self-administered scale. *Journal of sex education and therapy*, 16(3), 155-163.
- Holman, E. A., Garfin, D. R., & Silver, R. C. (2014). Media's role in broadcasting acute stress following the Boston Marathon bombings. *Proceedings of the National Academy of Sciences*, 111(1), 93-98.
- Hopf, D., Schneider, E., Aguilar-Raab, C., Scheele, D., Morr, M., Klein, T., ... & Eckstein, M. (2022). Loneliness and diurnal cortisol levels during COVID-19 lockdown: the roles of living situation, relationship status and relationship quality. *Scientific Reports*, 12(1), 15076.
- Huang, P. C., Latner, J. D., O'Brien, K. S., Chang, Y. L., Hung, C. H., Chen, J. S., ... & Lin, C. Y. (2023). Associations between social media addiction, psychological distress, and food addiction among Taiwanese university students. *Journal of Eating Disorders*, 11(1), 1-9.
- Hunt, M. G., Marx, R., Lipson, C., & Young, J. (2018). No more FOMO: Limiting social media decreases loneliness and depression. *Journal of Social and Clinical Psychology*, 37(10), 751-768.
- Jeste, D. V., Lee, E. E., & Cacioppo, S. (2020). Battling the modern behavioral epidemic of loneliness: suggestions for research and interventions. *JAMA psychiatry*, 77(6), 553-554.

- Jones, N. M., Garfin, D. R., Holman, E. A., & Silver, R. C. (2016). Media use and exposure to graphic content in the week following the Boston Marathon bombings. *American journal of community psychology*, 58(1-2), 47-59.
- Karney, B. R., & Bradbury, T. N. (1995). The longitudinal course of marital quality and stability: A review of theory, methods, and research. *Psychological bulletin*, 118(1), 3.
- Kolakowsky-Hayner, S.A., Goldin, Y., Kingsley, K., Alzueta, E., Arango-Lasprilla, J.C., Perrin, P.B., Baker, F.C., Ramos-Usuga, D. and Constantinidou, F., 2021. Psychosocial impacts of the COVID-19 quarantine: A study of gender differences in 59 countries. *Medicina*, 57(8), p.789.
- Latikka, R., Koivula, A., Oksa, R., Savela, N., & Oksanen, A. (2022). Loneliness and psychological distress before and during the COVID-19 pandemic: Relationships with social media identity bubbles. *Social Science & Medicine*, 293, 114674.
- Li, G., Tang, D., Song, B., Wang, C., Qunshan, S., Xu, C., ... & Cao, Y. (2020). Impact of the COVID-19 pandemic on partner relationships and sexual and reproductive health: cross-sectional, online survey study. *Journal of medical Internet research*, 22(8), e20961.
- Li, L. Z., & Wang, S. (2020). Prevalence and predictors of general psychiatric disorders and loneliness during COVID-19 in the United Kingdom. *Psychiatry research*, 291, 113267.
- Lin, C. Y., Broström, A., Griffiths, M. D., & Pakpour, A. H. (2020). Investigating mediated effects of fear of COVID-19 and COVID-19 misunderstanding in the association between problematic social media use, psychological distress, and insomnia. *Internet interventions*, 21, 100345.
- Lovibond, S. H., & Lovibond, P. F. (1995). Manual for the depression anxiety stress scales. Sydney, New South Wales, Australia: Psychology Foundation
- Masi, C. M., Chen, H. Y., Hawkey, L. C., & Cacioppo, J. T. (2011). A meta-analysis of interventions to reduce loneliness. *Personality and social psychology review*, 15(3), 219-266.
- Mirowsky, J., & Ross, C. E. (2002). Measurement for a human science. *Journal of health and social behavior*, 152-170.
- Morahan-Martin, J., & Schumacher, P. (2003). Loneliness and social uses of the Internet. *Computers in human behavior*, 19(6), 659-671.
- Naser, A. Y., Dahmash, E. Z., Al-Rousan, R., Alwafi, H., Alrawashdeh, H. M., Ghoul, I., ... & Alyami, H. S. (2020). Mental health status of the general population, healthcare professionals, and university students during 2019 coronavirus disease outbreak in Jordan: A cross-sectional study. *Brain and behavior*, 10(8), e01730.
- O'Day, E. B., & Heimberg, R. G. (2021). Social media use, social anxiety, and loneliness: A systematic review. *Computers in Human Behavior Reports*, 3, 100070.

- Omar, S. S., Dawood, W., Eid, N., Eldeeb, D., Munir, A., & Arafat, W. (2021). Psychological and sexual health during the COVID-19 pandemic in Egypt: are women suffering more?. *Sexual medicine*, 9(1), 100295-100295.
- Panicker, J.A., & Sachdev, R. (2014). Relations among loneliness, depression, anxiety, stress and problematic internet use. *International Journal of Research in Applied, Natural and Social Sciences*, 2(9), 1-10.
- Panzeri, M., Ferrucci, R., Cozza, A., & Fontanesi, L. (2020). Changes in sexuality and quality of couple relationship during the COVID-19 lockdown. *Frontiers in psychology*, 2523.
- Peplau, L.A., & Perlman, D. (1982). Perspectives on loneliness. In L. A. Peplau & D. Perlman (Eds.). *Loneliness: A sourcebook of current theory, research and therapy* (pp. 1-18). New York: John Wiley & Sons.
- Phu, B., & Gow, A. J. (2019). Facebook use and its association with subjective happiness and loneliness. *Computers in Human Behavior*, 92, 151-159.
- Pieh, C., O'Rourke, T., Budimir, S., & Probst, T. (2020). Relationship quality and mental health during COVID-19 lockdown. *PLoS One*, 15, 1– 10. <https://doi.org/10.1371/journal.pone.0238906>
- Pietromonaco, P. R., & Overall, N. C. (2020). Applying relationship science to evaluate how the COVID-19 pandemic may impact couples' relationships. *American Psychologist*, 76(3), 438– 450. <https://doi.org/10.1037/amp0000714>
- Prout, T. A., Zilcha-Mano, S., Aafjes-van Doorn, K., Békés, V., Christman-Cohen, I., Whistler, K., ... & Di Giuseppe, M. (2020). Identifying predictors of psychological distress during COVID-19: a machine learning approach. *Frontiers in Psychology*, 11, 586202.
- Qualter, P., Rouncefield-Swales, A., Bray, L., Blake, L., Allen, S., Probert, C., ... & Carter, B. (2021). Depression, anxiety, and loneliness among adolescents and young adults with IBD in the UK: the role of disease severity, age of onset, and embarrassment of the condition. *Quality of Life Research*, 30, 497-506.
- R Core Team (2021). *R: A language and environment for statistical computing*. R Foundation for Statistical Computing, Vienna, Austria. <https://www.R-project.org/>.
- Robillard, R., Saad, M., Edwards, J., Solomonova, E., Pennestri, M. H., Daros, A., ... & Kendzerska, T. (2020). Social, financial and psychological stress during an emerging pandemic: observations from a population survey in the acute phase of COVID-19. *BMJ open*, 10(12), e043805.
- Robillard, R., Saad, M., Edwards, J., Solomonova, E., Pennestri, M. H., Daros, A., ... & Kendzerska, T. (2020). Social, financial and psychological stress during an emerging pandemic: observations from a population survey in the acute phase of COVID-19. *BMJ open*, 10(12), e043805.
- Rokach, A. (2018). The effect of gender and culture on loneliness: A mini review. *Emerging Science Journal*, 2(2), 59-64.

- Rosseel, Y. (2012). lavaan: An R package for structural equation modeling. *Journal of statistical software*, 48, 1-36.
- Russell, D., Peplau, L. A., & Cutrona, C. E. (1980). The revised UCLA Loneliness Scale: concurrent and discriminant validity evidence. *Journal of personality and social psychology*, 39(3), 472.
- Tan, M., Shallis, A., & Barkus, E. (2020). Social anhedonia and social functioning: Loneliness as a mediator. *PsyCh journal*, 9(2), 280-289.
- Theiss, J.A. and Estlein, R., 2014. Antecedents and consequences of the perceived threat of sexual communication: A test of the relational turbulence model. *Western Journal of Communication*, 78(4), pp.404-425.
- Thomas, L., Orme, E. and Kerrigan, F., 2020. Student loneliness: The role of social media through life transitions. *Computers & Education*, 146, p.103754.
- Thompson, R.R., Garfin, D.R., Holman, E.A. and Silver, R.C., 2017. Distress, worry, and functioning following a global health crisis: A national study of Americans' responses to Ebola. *Clinical psychological science*, 5(3), pp.513-521.
- Ustun, G. (2021). Determining depression and related factors in a society affected by COVID-19 pandemic. *International Journal of Social Psychiatry*, 67(1), 54-63.
- Valkenburg, P.M. , & Peter, J. (2013). The Differential Susceptibility to Media Effects Model. *Journal of Communication*, 63(2), 221–243
- Van Buuren, S., & Groothuis-Oudshoorn, K. (2011). mice: Multivariate imputation by chained equations in R. *Journal of statistical software*, 45, 1-67.
- Victor, C. R., & Yang, K. (2012). The prevalence of loneliness among adults: a case study of the United Kingdom. *The Journal of psychology*, 146(1-2), 85-104.
- Wang, Y., Shi, L., Que, J., Lu, Q., Liu, L., Lu, Z., ... & Shi, J. (2021). The impact of quarantine on mental health status among general population in China during the COVID-19 pandemic. *Molecular psychiatry*, 26(9), 4813-4822.
- Wathelet, M., Duhem, S., Vaiva, G., Baubet, T., Habran, E., Veerapa, E., ... & D'Hondt, F. (2020). Factors associated with mental health disorders among university students in France confined during the COVID-19 pandemic. *JAMA network open*, 3(10), e2025591-e2025591
- Williams, S. E., & Braun, B. (2019). Loneliness and social isolation-a private problem, a public issue. *Journal of Family and Consumer Sciences*, 111(1), 7-14.
- World Health Organization. 2020 Coronavirus disease (COVID-19). 2020 Situation Report – 106. (Internet) (cited September 2023). See [https://www.who.int/docs/default-source/coronaviruse/situation-reports/20200505covid-19-sitrep-106.pdf?sfvrsn=47090f63\\_2](https://www.who.int/docs/default-source/coronaviruse/situation-reports/20200505covid-19-sitrep-106.pdf?sfvrsn=47090f63_2).
- Yang, K., & Victor, C. (2011). Age and loneliness in 25 European nations. *Ageing & Society*, 31(8), 1368-1388.
- Zhao, N., & Zhou, G. (2020). Social media use and mental health during the COVID-19 pandemic: Moderator role of disaster stressor and mediator role of negative affect. *Applied Psychology: Health and Well-Being*, 12(4), 1019-1038.



## POTENTIAL MECHANISMS UNDERLYING REAPPRAISAL STRATEGIES: AN EXPLORATORY STUDY

---

*Karol J. Wild<sup>1\*</sup>, Bianca Macavei<sup>2</sup>, and Adrian N. Opre<sup>3</sup>*

---

<sup>1</sup> Applied Cognitive Psychology Doctoral School, Department of Psychology, “Babes-Bolyai” University, Cluj, Romania. ORCID ID: <https://orcid.org/0000-0002-1453-5853>

<sup>2</sup> Applied Cognitive Psychology Doctoral School, Department of Psychology, “Babes-Bolyai” University, Cluj, Romania. ORCID ID: <https://orcid.org/0000-0003-4490-0089>

<sup>3</sup> Applied Cognitive Psychology Doctoral School, Department of Psychology, “Babes-Bolyai” University, Cluj, Romania. ORCID ID: <https://orcid.org/0000-0002-4041-0659>

---

### Abstract

Reappraisal strategies are vital for our psychological well-being. The way people feel, behave and react in different stressful situations, depends to a degree on the reappraisal strategies they use to manage their emotional states and to cope with a given situation. In this paper, we assess the types of reappraisal strategy described in the scientific literature from the point of view of a focus on specific cognitive strategies. Adopting a mixed research design, we used inductive content analysis in order to identify potential underlying mechanisms relating to qualitative patterns of thinking used in efficient reappraisal. Eight anger and anxiety eliciting situations were used to stimulate emotional responses and the use of reappraisal strategies. Based on our exploratory approach we identified four additional specific reappraisal strategies (justification, responsibly assumption, normality check, and non-justified acceptance) which can be used as specific intervention techniques. Awareness and core beliefs are cognitive processes that contribute to the understanding of inter-individual differences in the efficacy of the reappraisal process. Research areas for future studies are identified.

**Keywords:** reappraisal, emotional self-regulation, cognitive strategies, awareness.

---

\* Correspondence concerning this article should be addressed to Adrian N. Opre, Cluj-Napoca, Sindicatelor str. no.7, Cluj, Romania.  
Tel: +40 744 555 158  
E-mail: [adrianopre@psychology.ro](mailto:adrianopre@psychology.ro)

Cognitive reappraisal is a method for viewing an emotionally evocative event from a different perspective and for reinterpreting its meaning, in order to change its emotional impact (Fink et al., 2017; Ford & Troy, 2019; Lazarus & Alfert, 1964; Lazarus & Folkman, 1984; Newman & Nezlek, 2021; Perchtold et al., 2019).

Cognitive Reappraisal has been shown to be effective in more than just changing self-reported emotional experience (Hajcak et al., 2010, Ochsner & Gross, 2008, Sai et al., 2015). More specifically, it can play a role in the reduction of peripheral physiology and of brain activity associated with a variety of mental health problems, such as addiction, impulse control, schizophrenia and depression (Baur et al., 2015; Demaree et al., 2004; Foti & Hajcak, 2009; Kamburidis, 2024; Koob & Le Moal, 2001; Pavlov et al., 2014; Sai et al., 2015). In this way it could be one of the most important strategies used for emotional regulation (Sai et al., 2015).

As research by Perchtold et al., (2019) suggests, not all reappraisal strategies show the same efficacy level in changing dysfunctional emotional responses into adaptive responses. Furthermore, it has been hypothesized that not all forms of cognitive reinterpretation are beneficial. With regard to this McRae et al., (2012) state that in order to identify the difference in the efficacy and the emotional outcomes of the reappraisal strategies used by subjects there is a need to take the following three criteria into account: (a) the main goal of the reappraisal strategies (increasing positive versus decreasing negative emotions); (b) the reappraisal tactics used to challenge reality; and (c) the extent to which the effect on regulating emotions is dependent upon changes in the first two criteria. Previous studies have demonstrated that an increase in the frequency of the use of reappraisal strategies can increase a subject's well-being (Deplancke et al., 2022; Ford et al., 2017; Newman & Nezlek, 2021). These results do not offer a clear perspective on the underlying cognitive mechanism. Ford & Troy (2019) formulated a conceptual framework that identified some drawbacks in current research, and recommended directions for future research, two of which focused on identifying the mechanisms that are responsible for inter-individual differences, and on designing interventions that best assist individuals in stressful situations.

According to Brans and Verduyn (2014), in order to have a better understanding of emotional experience in specific situations, it is necessary to establish both the nature of an emotion and also its intensity and its duration (Verduyn et al., 2009; Verduyn et al., 2012). Verduyn et al. suggest that this approach could be useful, even in cases of self-reported assessment. In more specific terms, the use of discrete emotional categories (such as anger, fear, etc.) as well as non-discrete emotional dimensions (such as valence and arousal) (Betella & Verschure, 2015; Marchewka et al., 2013; Riegl et al., 2015) could contribute to our understanding of the differences in emotional response in different reappraisal strategies.

Studies on the influence of reappraisal strategies on recalling and recognising emotionally loaded stimuli or events (Erk et al., 2010; Wang et al.,

2017), can be seen as demonstrating indirect long term benefits from the habitual use of reappraisal strategies. More specifically, Wang et al. (2017) show that up-regulation and down-regulation cognitive reappraisal strategies increase performance in recalling explicit memories of the emotional content of stimuli without specifying the level of emotional re-experience. Erk et al. (2010) concluded that memory for emotionally encoded stimuli is explained by emotional re-activation, whereas memory for items successfully encoded during emotion regulation is explained by recognition of features and cognitive content, suggesting that the level of cognitive processing of emotional stimuli could contribute to (a) a lower level of re-activation of the emotion eliciting memories, and (b) could increase the efficacy of a long term of change in beliefs at a higher level of generality. This would decrease the level of re-activation of emotional responses to stimuli for which reappraisal was used during the time of encoding. From this perspective, the emotional outcome of reappraisal strategies could be due to (a) the direct effect of challenging the cognitive content, and (b) the influence of mediated thought on other cognitive processes, such as attention and memory.

In our study we aim to identify whether there are cognitive dimensions or mechanisms that have been missed when attempting to understand the difference in efficacy level when changing a dysfunctional emotional response into an adaptive response. As an initial step we review the specific criteria used in the scientific literature to categorize different reappraisal strategies.

### *Similarities between reappraisal strategies*

Different studies and different authors tend to use different criteria to categorise reappraisal strategies (Bintaş-Zörer & Yorulmaz, 2021). There are studies which are focus only on a particular reappraisal strategy, such as using a humorous perspective in an aversive situation (Fink et al., 2017; Perchtold et al., 2019). Other researchers offer an exhaustive categorisation of reappraisal strategies (Gross and Thompson, 2007; McRae et al., 2012; Webb, et al., 2012). There are many similarities and differences which can be found between different categories. Firstly, we propose to identify the similarities.

#### *Changes in how we think about the situation.*

From the definition of reappraisal strategies we can already expect a level of reinterpretation of aversive events. We identified three ways in which the authors that offer a complex description of reappraisal strategies focused on the event show similarities:

A. Normality - One overlap between the meta-analysis of Webb et al. (2012) and the reappraisal tactics coding guide proposed by McRae et al. (2012) is that the reappraisal of an emotional response or aversive event is seen as a normal part of living. McRae et al. (2012) focused on categorising reappraisal strategies as

thought processes, describe this category as *acceptance* (including aversive events as stimuli), while Webb, et al. (2012) focused on describing the object of the reappraisal by the use of the term *reappraisal of the emotional response*. Some more recent studies suggest that reappraisal strategies that have a clear correspondence with the client's real life experiences are the only ones that offer clear replicability of their effects in changing positive and negative emotional states (Brockman et al., 2023, Wang & Yin, 2023)

B. Diminution of negative evaluation - reinterpretation of the emotional stimuli, events or suffering in a way that suggests that things are not as bad as they seem, that there could be positive outcomes, or which serve to remind us that we can't predict the future are all included in a single category by Gross and Thompson (2007); Webb, et al. (2012). However, these are divided into three different categories by McRae et al. (2012).

C. Humouristic and negation - Fink et al. (2017), Nook et al. (2020) and Papousek et al. (2019) describe multiple humouristic strategies based on their linguistic style, such as metonymy, metaphor, polysemy and so on. All of these function as ways of distancing oneself from aversive events. The idea of distancing or negation is also described by McRae et al. (2012), alongside two reappraisal strategies, reality challenging and distancing, which involve the idea that the events which occur or that the emotional loaded stimuli are not real or authentic, or that they are something other than they appear to be. Nook et al. (2020) discuss the role of linguistic markers as demonstrating the subjects spatial, social and temporal distancing from a potentially aversive event, such as the replacement of first person pronouns with third person pronouns. They suggest that there is a bi-directional relationship between reappraisal and linguistic distancing.

#### *Perspective taking in a situation*

These reappraisal strategies focus on changes in the way a situation is viewed (Gross and Thompson, 2007; McRae et al., 2012; Papousek et al., 2019; Webb, et al., 2012), and on the ways the impact of an emotional stimulus is altered by adopting a more or a less objective perspective. It is possible for a person to imagine themselves as objectively placed with regard to a situation, or they can view the stimulus from the perspective of an external observer, or see it as a fantasy, or from the point of view of a narrator.

#### *Differences between reappraisal strategies*

The degree of generalisation in the description of reappraisal strategies by different authors differs significantly, but there is also a lack of overlap between them. Consequently, in the following we describe the reappraisal categories that are presented by only some of the writers in this field.

*Problem solving*

A major difference between authors is that it is only McRae et al. 2012 who describe reappraisal as the assessment of the capacity to cope with a specific situation, as a form of problem solving, and as a thinking strategy, and places two different reappraisal strategies in this category. The first strategy, Technical-Analytic-Problem Solving, (McRae et al., 2012), focuses on internal resources, while the second strategy, Agency, focuses on external resources (McRae et al., 2012). One possible reason why some authors such as Lennarz et al. (2018) do not include problem solving in the category of reappraisal strategy may be that they define this as an emotional regulation strategy, which they see as an entirely different kind of strategy.

*Variety in operationalisation of reappraisal strategies*

In the literature, reappraisal strategies are described in a variety of ways, from strategies such as: (a) reappraisal attempts and reappraisal successes (Ford et al., 2017; Ford & Troy, 2019); (b) reappraisal frequency, repertoire, context sensitivity and feedback loop (Bonanno & Burton, 2013); (c) reappraisal fluency and reappraisal flexibility (Zeier et al., 2019); (d) automatic and controlled reappraisal processes (Sheppes et al., 2014); and studies which restrict the reappraisal strategies used by their subjects in order to assess their efficacy (Koenigsberg et al., 2010, Ochsner et al., 2004, Papousek et al., 2019). All these studies (see table 1) have an important contribution to make but are limited when it comes to offering a comprehensive view of the underlying mechanisms of reappraisal strategies that contribute to differences in outcome.

**Table 1.** Synthesis of the reappraisal categories definitions

Study	Similarities		Differences		
	Normality	Diminution of negative evaluation	Humouristic, linguistic and negation	Problem Solving	<i>Variate general definitions</i>
McRae et al., (2012)	Acceptance	Change Current Circumstances. Change future Consequences, Explicit Positive	Reality Challenge, Distancing	Technical-Analytic-Problem Solving as a reappraisal strategy	Agency is a reappraisal strategy focused outside help
Papousek et al., (2019)	Different World of Experience		Metonymy, Metaphor, Polysemy, Word Play, Fantasy and Fiction, Narrative		

## Articles Section

Study	Similarities		Differences		
	Normality	Diminution of negative evaluation	Humouristic, linguistic and negation	Problem Solving	<i>Variate general definitions</i>
Nook et al., (2020)			Change of Perspective third person pronouns		
Gross and Thompson (2007), Webb, et al., (2012)	Reappraisal of the emotional response, Perspective taking	Reappraise emotional stimulus			Reappraisal mixed
Lennarz et al., (2018)	Acceptance	Reappraisal	Distractions, avoidance, suppression	reappraisal, acceptance and problem solving different emotional regulation strategies	Social support
Bonanno & Burton, 2013					frequency, repertoire, context and feedback
Sheppes et al., 2014					automatic and controlled reappraisal process
Zeier et al., 2019					appraisal fluency and reappraisal flexibility
Ford et al., 2017; Ford & Troy, 2019					reappraisal attempt and reappraisal success

The cells include the name of the reappraisal categories described by the different authors.

The approach, proposed by McRae et al. (2012), and Webb et al. (2012), adopts a more complex way of categorising reappraisal strategies. While the categorisation of reappraisal strategies offered by Webb et al. (2012) focuses

predominately on the object of the reappraisal (event, emotional response), McRae et al. (2012) use guidelines for coding reappraisal tactics, as is shown in table 1. The authors identify differences in emotional outcomes at the content/semantic level, dependent upon the goal of the subject's increase in positive emotions, rather than a decrease in negative emotions.

The categorization used by McRae et al. (2012), in order to code the answers of the participants, use criteria that best express the underlying cognitive strategies and changes in cognitive content, when compared with the other types of categorization. The limitation of this approach is that this way of categorizing, used as a standard way of classifying the answers of participants, implies that reappraisal strategies, which could be better described by cognitive mechanisms that fall outside McRae's categorisation, could be assigned to one of these standard categories. A second limitation is the possibility that different categories could overlap, such as present as opposed to future consequences in the case of situation based change. The underlying criteria for categorization used can be analysed as (a) valence - positive versus negative, (b) timing - present versus future, and (c) subject - situation based versus emotion based.

All these above-mentioned limitations can be translated into difficulties in developing the most efficient interventions to prevent or diminish possible mental health problems which are related to limited emotion regulation abilities. The principal reason for variations in reappraisal effects on well-being could be due to the multidimensionality of factors involved, which include such things as beliefs (Deplancke et al., 2022), the number of daily life events (Newman & Nezlek, 2021), and the discrepancy between attempts at reappraisal and the successful implementation of reappraisal strategies (Ford et al., 2017). The potential mechanisms underlying the differences in efficacy of reappraisal strategies are well covered by the literature (Brockman et al., 2023, Cohen Ben Simon et al., 2022, Wang & Yin, 2023) but are often not included in studies that try to explore the differences in the efficacy of reappraisal strategies. In so far as reappraisal strategies are not well defined, it is important to distinguish between the variations in the effectiveness of reappraisal based training/interventions which are due to inter-individual differences and those which are due to differences in applied reappraisal strategies.

### *Purpose of the present study*

Our exploratory study had as its principal aim the identification of potential mechanisms underlying reappraisal strategies (Brockman et al., 2023, Cohen Ben Simon et al., 2022, Wang & Yin, 2023). More specifically, our aim was to identify and define reappraisal strategies and the possible underlying cognitive mechanisms which can be effectively used as techniques in self-regulation training intervention. The questions that our study aimed to answer were: (a) are specific

reappraisal strategies well enough defined in the scientific literature to allow them to be used in training programs; and (b) what cognitive processes are activated during the reappraisal process that can influence emotional outcomes.

Based on the earlier findings and on our research goals, we used a mixed research design: (a) inductive content analysis with the goal of identifying possible missing underlying reappraisal mechanisms; and (b) the measurement of pre- vs. post-intervention emotional responses (non-discrete and discrete measurement of emotion) in order to verify the efficacy of the reappraisal strategies that emerged. We expected that the level of discrete and non-discrete negative emotion would be significantly lower in the post-reappraisal phase. (Bonanno & Burton, 2013; Deplancke et al., 2022; Fink et al., 2017; Ford et al., 2017; Lazarus & Alfert, 1964; Lazarus & Folkman, 1984; Newman & Nezelek, 2021; Perchtold et al., 2019; Sai et al., 2015; Scult et al., 2016; Sheppes & Gross, 2010; Sheppes et al., 2012).

## **Method**

### *Participants*

Our sample consisted of 24 subjects from Romania from a variety of occupational backgrounds (executive directors, managers, a medical assistant, a make-up artist, a teacher, a freelancer, a student, a salesperson, an accountant, a housewife, a chef, a factory-worker, and a cashier) with a mean age of 33.0 years (19-56 years,  $SD = 10.3$ , 79.2 % female). The subjects were Romanian, Hungarian and German. 37.5 % were married, 4.2 % engaged to be married, 16.7 % divorced or widowed, and 41.7 % were neither married nor engaged to be married, nor divorced nor widowed. The participants' educational background was as follows: 62.5% had completed high-school; 8.3% had a bachelor's degree; and 29.2% had a master's degree. We tested the saturation of the sample size using the code meaning method (Hennink & Kaiser, 2022), and the sample reached saturation at 12 subjects. Participants volunteered for the study, and no incentives for participation were offered. Data was collected between November 2020 and March 2021. An information sheet and a consent form were included at the beginning of the study. The participants were informed that they could decide not to answer questions and could withdraw at any time, and that the information collected was confidential and would be used solely for the present study. Approval for the project was obtained from the appropriate review committees at the authors' institutions. The group was selected so as to include members of the general population with no previous history of mental health problems. We used as a criterion for inclusion, that the subjects be active healthy subjects from a wide range of backgrounds. We excluded from the study anyone with a previous diagnosis of depression, anxiety or any other

psychopathology. The participants were recruited using an invitation email sent to an email list of university students and graduates.

### *Measures*

#### *Emotional response*

We used the self-assessment method described by Riegl et al. (2015), (Betella & Verschure, 2015; Marchewka et al., 2013). Discrete emotional categories (joy, anger, fear, disgust, pity, sadness and surprise) were measured using a 5 point Likert scale (from 1- absent to 5- high). Non-discrete emotional dimensions (valence, arousal, approach) were measured using a 5 point Likert scale (where the value 3 was the neutral value between the two extremes, for example, between negative and positive in the case of valence).

#### *Reappraisal strategies*

We used the Reappraisal Inventiveness Test (RIT) developed by Weber et al. (2013). RIT is a way of measuring reappraisal strategies by using four anger eliciting vignettes (Weber et al., 2013) and four anxiety eliciting vignettes (de Assuncao et al., 2015; Perchtold et al., 2019) which present subjects with the kinds of emotion eliciting situations that can occur in everyday life. The vignettes were adapted, first by enhancing the original description of every situation with sensory clues (Andrade et al., 2012; Schifferstein, 2009) in order to facilitate the process of identifying and imagining the aversive situation. Second, we replaced some locations or details to make them easier for a broader population to relate to. For example: the original vignette (Weber et al., 2013) is as follows: *Kitchen. You invite friends over for a meal, but when you step into the kitchen of your home (instead of flat), the entire kitchen is full of dirty dishes, looks dingy and unpleasant, and there is a smell of onions and other unpleasant food smells (instead of is a mess). Yesterday, your partner (instead of flatmate) had promised to clean up the kitchen by today. When you go to talk to your partner, he/she tells you that he/she is watching TV and doesn't feel like cleaning up.* A picture, which illustrated the main theme of the vignette, accompanied each vignette. For example, for the situation in which the person is contacted by a doctor for further tests, a picture of a doctor was included.

### *Procedure*

The data was collected online using google meets, in order to record the audio/video call, after the participants had provided their email addresses and indicated their availability. In order to undertake an inductive content analysis, the content of the recordings was transcribed. Demographic information was collected from participants who agreed to the use of their data in accordance with research specific legal regulations.

The questions that our study aimed to answer are: (a) are specific reappraisal strategies well enough defined in the scientific literature to allow them to be used in training programs; and (b) what cognitive processes are activated during the reappraisal process that can have an effect on emotional outcomes. By starting with these questions, an exploratory mixed research design emerged as the optimal research approach. The inductive content analysis was conducted by the authors. In the first instance, we used the McRae et al. (2012) reappraisal tactic coding guide as a basis. We analysed the similarities and differences between the reappraisal categories used in our study and those used by McRae et al. (2012). We aimed to identify categories which had not been included with a view to showing how they could be transformed into specific intervention techniques. Secondly, we aimed to identify cognitive processes that might possibly be present and which could impact on the use of reappraisal strategies (Brockman et al., 2023, Cohen Ben Simon et al., 2022, Wang & Yin, 2023). In order to validate the possible reappraisal strategies which we identified, we measured the changes in emotional responses. We used the code meaning method described by Hennink and Kaiser (2022) and inductive content analysis. The fact that after 12 subjects the authors did not find any new reappraisal strategies suggested that the saturation point of possible reappraisal strategies had been reached.

For each vignette/emotion evoking situation data was collected in three stages, as follows: (a) subjects were instructed to read the vignette aloud and to imagine the situation happening to them. They were then asked to assess their emotional response by selecting a field from the form provided; (b) the subjects were then asked to try to think of and describe out loud as many ways as possible of appraising the specific situation in ways which diminished their negative emotions; and (c) the subjects were asked to reassess their emotional response to the situation, and the content of the vignette was displayed again so that it could be read again (Perchtold et al., 2019; Weber et al., 2013). A google form was used during the video call to record the pre- and post-reappraisal task assessments of their emotional responses.

### *Statistical Analysis*

Descriptive analyses were conducted with JAMOVI. In order to determine and test the relationship between the variables we used the following calculations and statistical tests (to a 95 % Confidence Interval): (a) Descriptive statistics; and (b) the Wilcoxon test for paired samples pre- vs post-self-regulation comparison test. The Wilcoxon test was used in order to compare the pre- and post-intervention emotional responses, based on the non-parametric characteristics of our results.

**Results**

We tested the normality of the distributions for all the measurements of emotion responses. The results of the Shapiro-Wilks test indicated that the distributions of the emotional response variables did not approximate a normal distribution, ( $p < .001$ ). As follows, we decided to use non-parametrical comparison tests.

*Non-discrete emotional response*

Comparing the emotional responses operationalized through non-discrete measurements obtained between the first and third steps of our study, before and after the reappraisal task, we obtained statistically significant changes in the level of valence (Wilcoxon  $W$  anger = 92.0  $p < .001$ ,  $Cohen\ d = -0.909$ ;  $W$  anxiety = 116.5  $p < .001$ ,  $Cohen\ d = -0.713$ ), arousal (Wilcoxon  $W$  anger = 2536.0  $p < .001$ ,  $Cohen\ d = 1.012$ ;  $W$  anxiety = 2248.5  $p < .001$ ,  $Cohen\ d = 0.792$ ) and approach (Wilcoxon  $W$  anger = 621.0  $p = .004$ ,  $Cohen\ d = 0.298$ ;  $W$  anxiety = 158.0  $p = 0.045$ ,  $Cohen\ d = -0.211$ ) for both anger and anxiety eliciting situations, with a higher effect value for arousal and valence. This exploratory approach suggest that the reappraisal strategies applied by the subjects were effective in changing their emotional states.

*Discrete emotional Response*

Table 2 shows that the main differences between pre- and post-intervention results with regard to the anger and anxiety vignettes consisted in values that are not statistically significant. In the case of anger eliciting situations, the pre-/post-intervention comparison did not show statistically significant differences for pity (Wilcoxon  $W$  pity = 220.5,  $p = .693$ ,  $Cohen\ d = 0.0309$ ,  $m^{T1} = 1.66$ ;  $m^{T2} = 1.63$ ), and showed the lowest effect size for fear ( $Cohen\ d = 0.2268$ ). In the case of anxiety eliciting situations, the pre-/post-intervention comparison did not show statistically significant differences for disgust (Wilcoxon  $W$  fear = 284.5,  $p = .147$ ,  $Cohen\ d = 0.303$ ;  $m^{T1} = 1.59$ ;  $m^{T2} = 1.42$ ).

**Table 2.** Comparison between pre- and post-reappraisal tasks for anger and anxiety eliciting vignettes

	Paired Samples		Wilcoxon-Test		$W$	$p$	$Cohen's\ d$
	Pre		Post				
	$M$	$SD$	$M$	$SD$			
joy A	1.52	0.882	2.46	1.436	88.0 <sup>a</sup>	<.001	-0.7100

	Paired Samples Wilcoxon-Test				<i>W</i>	<i>p</i>	<i>Cohen's d</i>
	Pre		Post				
	<i>M</i>	<i>SD</i>	<i>M</i>	<i>SD</i>			
anger A	3.11	1.391	1.77	1.110	2593.5 <sup>b</sup>	<.001	1.0115
fear A	1.51	0.973	1.28	0.676	227.5 <sup>d</sup>	0.025	0.2268
disgust A	2.90	1.511	1.90	1.235	1630.0 <sup>e</sup>	<.001	0.7804
pity A	1.66	1.055	1.63	0.987	220.5 <sup>f</sup>	0.693	0.0309
sadness A	2.71	1.479	1.88	1.233	1408.0 <sup>g</sup>	<.001	0.5387
surprise A	3.26	1.510	2.11	1.204	1676.0 <sup>h</sup>	<.001	0.7365
joy B	1.85	1.036	2.51	1.346	175.0 <sup>i</sup>	<.001	-0.764
anger B	1.94	1.230	1.47	0.845	681.0 <sup>j</sup>	<.001	0.660
fear B	3.07	1.431	2.24	1.074	1796.0 <sup>k</sup>	<.001	0.900
disgust B	1.59	1.082	1.42	0.890	284.0 <sup>l</sup>	0.147	0.303
pity B	1.84	1.146	1.46	0.882	445.0 <sup>m</sup>	<.001	0.684
sadness B	1.96	1.289	1.54	0.917	616.0 <sup>n</sup>	<.001	0.663
surprise B	2.86	1.441	1.96	1.160	1370.0 <sup>p</sup>	<.001	0.915

a 41 pair(s) of values were tied, b 23 pair(s) of values were tied, d 72 pair(s) of values were tied, e 38 pair(s) of values were tied, f 68 pair(s) of values were tied, g 39 pair(s) of values were tied, h 36 pair(s) of values were tied, i 42 pair(s) of values were tied, j 56 pair(s) of values were tied, k 35 pair(s) of values were tied, l 67 pair(s) of values were tied, m 64 pair(s) of values were tied, n 58 pair(s) of values were tied, p 43 pair(s) of values were tied.

A = anger eliciting vignettes, B = anxiety eliciting vignettes

### Cognitive and Reappraisal strategies

Based on the inductive content analysis, we identified 17 cognitive and reappraisal strategies used by the subjects in our sample to change their emotional responses to the situations presented in the vignettes. The participants used the reappraisal strategies to different degrees, (lowest value 0, highest value 16, *media n* = 4, *m* = 4.32, *SD* = 2.51). The subjects who used zero reappraisal strategies (in 3.4% cases) applied avoidance, distraction or emotional detachment instead as self-

regulation techniques. The frequencies for the entire sample can be seen in Figure 1. The cognitive and reappraisal strategies identified could be divided into at least two categories, (a) 11 effective emotion and reality focused reappraisal strategies, and (b) 6 additional cognitive processes that were used alongside self-regulation processes, such as awareness, beliefs, and avoidance/emotional detachment as alternatives to reappraisal. A complete description of the categories identified and their relation to the categories described in the introduction to our study can be found in appendix A of this paper.

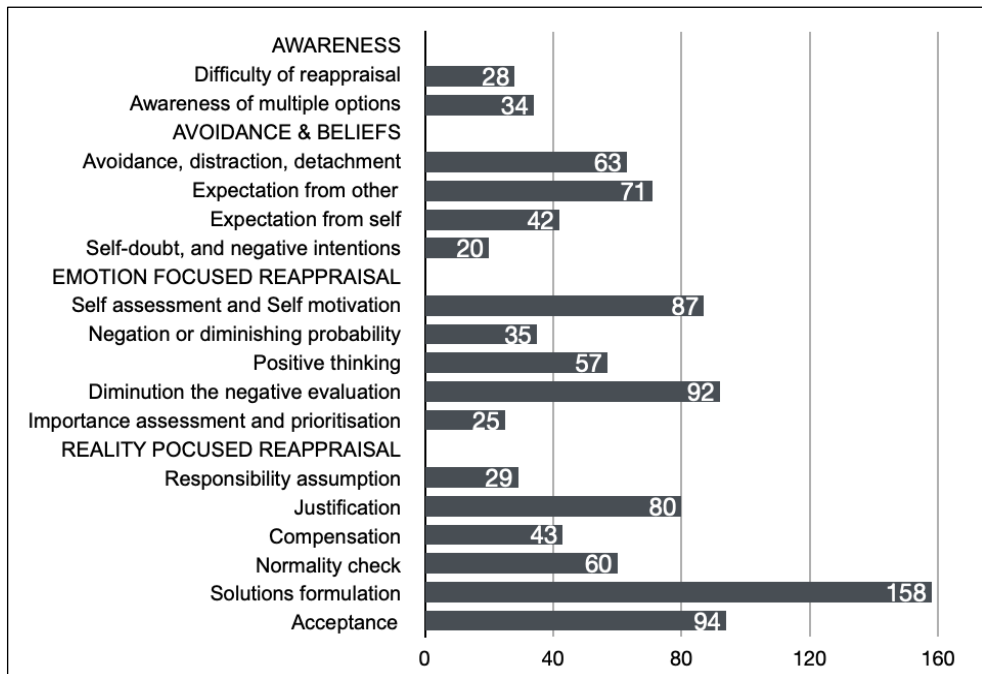

**Figure 1.** Frequency of reappraisal strategies and additional cognitive content

*Note.* As a point of reference for assessing the frequency of each reappraisal strategy, there are 192 total situations (value that is calculated multiplying the 8 emotions eliciting situation with  $N = 24$  subjects)

## Discussion

In our attempt to find possible underlying mechanisms in order to understand the variation in the efficacy of reappraisal strategies for the regulation of unwanted emotions (Deplancke et al., 2022; Ford et al., 2017; Ford & Troy 2019; Newman &

Nezlek, 2021), we identified (a) awareness as a possible mediator, (b) eleven reappraisal strategies, and (c) two cognitive processes which could have a role in the efficacy of reappraisal as an emotional self-regulation strategy (Brockman et al., 2023, Cohen Ben Simon et al., 2022, Wang & Yin, 2023).

*Changes in emotional response to stress eliciting situations*

Based on our results, the reappraisal strategies were effective in changing the emotional response of the participants. This can be seen as a first level of validation of our forward analysis of the identified reappraisal strategies. The results for pity and for anger eliciting situations and for disgust in anxiety eliciting situations were to some degree expected, based on Kollias et al.'s (2019) emotion wheel, using arousal, valence, level of control, and obstructiveness as criteria to assess emotions that have a high probability of being present together at the same time. Secondly, based on the fact that the initial values for pity and anger were in each case almost at the baseline, almost no change could occur. Thirdly, this could suggest that participants used reappraisal strategies primarily focused on the main emotions elicited by the vignettes they were given.

Approach as a non-discrete measure of emotion can be best seen as an assessment of a behavioral tendency or as the consequence of an emotional response. Avoidance can be seen as an expected behavioural response to anxiety. It is possible that approaching an anger eliciting situation is an expected behavioural response to anger as an emotion. The lower effect size of the pre- vs post- intervention for anger and anxiety on the approach scale, could be explained by the above expected behavioural tendencies.

*Awareness and reappraisal strategies*

In the process of identifying multiple reappraisal strategies which serve to regulate emotions we identified three levels of awareness: (a) subjects who were unable to find a different point of view for the situation and verbalized their difficulty in reappraising the imagined situations; (b) subjects who were easily able to find reappraisal strategies but were limited to one version of the imagined situation; and (c) subjects who could imagine variations from the situation and found different reappraisal strategies, depending on the context, or, in other words, subjects who were aware of multiple possibilities.

These results suggest that a higher level of awareness could make an important contribution to the effectiveness of finding and applying reappraisal strategies. Some recent studies trying to test and elaborate a model for the mindfulness-to-meaning theory have used multivariate path analysis (Cheung & Ng, 2020; Hanley et al., 2021; Garland, Hanley, Goldin & Gross, 2017), and show a similar relationship between awareness and reappraisal. More specifically, Hanley

et al. (2021) present a model based on longitudinal data in which mindfulness interventions contribute to decentering which could contribute to broadening awareness, which in turn can lead to increased positive reappraisal, which again in turn can contribute to a higher level of well-being. These studies refer to a residual effect of mindfulness-based stress training that manifests itself over time. In our study the effect of awareness appears to occur simultaneously with the process of reappraisal, which raises questions about the possibility of a more direct and simultaneous effect. This question is in accord with the findings of Füstös et al. (2013) that interoceptive awareness facilitates the down-regulation of emotions, which were measured at the physiological level (Brockman et al., 2023, Cohen Ben Simon et al., 2022, Wang & Yin, 2023).

#### *Two principal additional reappraisal strategy groups*

The reappraisal strategies identified include additional strategies described by McRae et al. (2012). Acceptance is a reappraisal strategy that normalizes the negative event and can include a wide perspective concerning negative things that happen (McRae et al., 2012). We identified four reappraisal strategies that could be included in this category and we think it could be beneficial when undertaking future interventions and training to include (a) justification, (b) responsibly assumption, (c) normality check, and (d) acceptance, as we have defined them in the appendix A, each to be treated and studied separately. Each of these four reappraisal strategies has a very clear goal, is quite specific, and is clear to follow in practice, and their efficacy will need to be tested by future studies. Compensation for negative events stood-out in the content analysis as an additional reappraisal strategy, being focused on finding something useful, although not necessarily something positive, about anger or anxiety eliciting situations.

The reappraisal strategies with the highest frequency were solution search and solution formulation. Subjects generated multiple solutions for some of the anger and anxiety eliciting situations, for example, a situation in which they had to imagine that in the middle of night, they were woken by a loud noise coming from their living-room and saw an open window in their living-room. Based on our exploratory approach, the question arises whether the type and number of reappraisal strategies could be influenced by the characteristics of a specific given situation.

#### *Beliefs and Reappraisal strategies*

The focus of the participants in our study on the verbalization of their expectations regarding themselves and others appears to have made them defocus on finding reappraisal strategies. This observation suggests that the activation of some beliefs about expected behaviour or results in a specific stressful situation could interfere with the process of finding and applying effectively reappraisal strategies

as emotional self-regulation. Previous studies highlight the important relationship between beliefs and self-regulation efficacy, and this has also been identified in other studies (Akyunus et al., 2021; Buffie & Nangle, 2022; Deplancke et al., 2022; Ford et al., 2018), which studied beliefs about emotional controllability and their impact on using reappraisal strategies to self-regulate. Ford et al. (2018) found, using a diary-based study, that entity beliefs were associated with reappraisal strategies which were little used in everyday life. These studies suggest that our finding that a main focus on beliefs and expectations regarding how a situation could or should be, may serve to interfere with the process of finding and applying effective reappraisal strategies.

### *Limitations and Future Directions*

The limitations of our study are due to the characteristics of our exploratory mixed design. First the instructions to the subjects to verbalize identify reappraisal strategies could have influenced their thought process and could have captured only the declarative elements. Secondly, the relative short time between the pre- and post-assessment of emotional response with regard to the presented stress eliciting situations means that the participants responses could have been influenced by response expectancy. Thirdly, the specific situations could have influenced what kind of reappraisal strategies would be more likely to be activated or used. These three limitations lead us to be cautious about our conclusions, without undertaking future research to test them. Our fourth limitation could support the findings we obtained, namely, that some of the subjects stated in the post-experiment debriefing that in some cases during the reading of the emotion eliciting vignettes for the first time, before having been given the task of reappraising the situation, and before assessing their initial emotional response, they had already considered alternative interpretations of the event.

### *Conclusion*

Our exploratory study had as its primary goal the identification of possible underlying mechanisms with regard to reappraisal strategies. The questions that our study aimed to answer were, (a) are specific reappraisal strategies well enough defined in the scientific literature to allow them to be used in training programs, and (b) what cognitive process are activated during the reappraisal process that can influence emotional outcomes. Our results are important because they could help, through future studies, to provide a better understanding of the variations in efficacy of reappraisal strategies through: (a) the identification of eleven clearly defined reappraisal strategies which offer specific and focused reappraisal strategies that can be taught as cognitive intervention techniques; (b) the four reappraisal strategies that could be included in acceptance, which could significantly contribute to a better

understanding of the variation in efficacy of reappraisal strategies; and (c) the question of whether some reappraisal strategies could be facilitators of the reappraisal process (see the description of positive self-assessment, self-motivation and importance assessment, and prioritization from Appendix A.)

Our work represents a contribution to the existing literature in two ways. Firstly, it identifies the specific cognitive techniques that emerged from the clear definition of the four identified acceptance focused reappraisal strategies. And secondly, it shows that awareness and activation of specific beliefs can influence the self-regulation process.

We believe that our results suggest two main directions for future research. One direction would be to study the possible mediation role of awareness and expectation in the efficacy of reappraisal strategies. A second direction would be orientated towards testing the efficacy of training and intervention based on the eleven identified reappraisal strategies.

We consider that our study points out some of the important factors involved in the variation in efficacy of reappraisal as an emotional self-regulation strategy, as presented in the existing scientific literature.

## Authors' Note

**Conflict of Interest.** The authors hereby declare that there are no potential conflicts of interest associated with this publication, and that no financial support has been received.

## References

- Akyunus, M., Gençöz, T. & Karakose, S. (2021). The Mediator Role of Negative Cognitive Emotion Regulation Strategies Between Interpersonal Problems and Borderline Personality Beliefs. *Journal of Rational-Emotive & Cognitive-Behaviour Therapy* 39, 322–334 (2021). <https://doi.org/10.1007/s10942-020-00373-0>
- Andrade, J., May, J., Kavanagh, D. (2012). Sensory Imagery in Craving: From Cognitive Psychology to New Treatments for Addiction. *Journal of Experimental Psychopathology*. 3(2),127-145. doi:10.5127/jep.024611
- de Assuncao, V. L., Golke, H., Geisler, F. C., & Weber, H. (2015). Reappraisal inventiveness: Eine emotionsübergreifende Fähigkeit [reappraisal inventiveness: A trans-emotional ability]. Paper, presented at the 13th conference of the Fachgruppe Differentielle Psychologie, Persönlichkeitspsychologie und Psychologische Diagnostik, Mainz, Germany.

- Baur, R., Conzelmann, A., Wieser, M. J., and Pauli, P. (2015). Spontaneous emotion regulation: differential effects on evoked brain potentials and facial muscle activity. *Int. J. Psychophysiol.* 96, 38–48. doi: 10.1016/j.ijpsycho.2015.02.022
- Betella, A., Verschure, P.F.M.J. (2016). The Affective Slider: A Digital Self-Assessment Scale for the Measurement of Human Emotions. *PLoS ONE* 11 (2), e0148037. doi:10.1371/journal.pone.0148037
- Bintaş-Zörer, P., & Yorulmaz, O. (2021). A New Instrument for Assessment of Emotion Regulation: The Emotion Regulation Interview-Revised Form. *Journal of Evidence-Based Psychotherapies*, 21(2).
- Bonanno, G.A., Burton, C.L. (2013). Regulatory Flexibility: An Individual Differences Perspective on Coping and Emotional Regulation. *Perspective on Psychological Science*, 8(6), 591-612. <https://doi.org/10.1177/1745691613504116>
- Brans. K., Verduyn. P., (2014) Intensity and duration of negative emotions: comparing the role of appraisals and regulation strategies. *PLoS One*. Mar 26;9(3):e92410. doi: 10.1371/journal.pone.0092410
- Brockman, R., Ciarrochi, J., Parker, P., and Kashdan, T. B. (2023). Behaving versus thinking positively: When the benefits of cognitive reappraisal are contingent on satisfying basic psychological needs. *J. Context. Behav. Sci.* 27, 120–125. doi: 10.1016/j.jcbs.2023.01.005
- Buffie, M.L., Nangle, D.W. (2022). The Interaction Between Self-Regulation Deficits and Negative Problem Orientation Exacerbates Depressive, but not ADHD Symptoms. *Journal of Rational-Emotive & Cognitive-Behaviour Therapy* 40, 647–662. <https://doi.org/10.1007/s10942-021-00432-0>
- Demaree, H., Schmeichel, B., Robinson, J., and Everhart, D. E. (2004). Behavioural, affective, and physiological effects of negative and positive emotional exaggeration. *Cogn. Emot.* 18, 1079–1097. doi: 10.1080/02699930441000085
- Cheung, R. Y. M., & Ng, M. C. (2020). Dispositional mindful awareness and savoring positive experiences: A prospective test of cognitive reappraisal as a mediator. *Personality and Individual Differences*, 163, 110050. <https://doi.org/10.1016/j.paid.2020.110050>
- Deplancke, C., Somerville, M.P., Harrison, A. *et al.*, (2022). It’s all about beliefs: Believing emotions are uncontrollable is linked to symptoms of anxiety and depression through cognitive reappraisal and expressive suppression. *Current Psychology*. <https://doi.org/10.1007/s12144-022-03252-2>
- Erk, S., Von Kalckreuth, A., and Walter, H. (2010). Neural long-term effects of emotion regulation on episodic memory processes. *Neuropsychologia*, 48, 989–996. <https://doi.org/10.1016/j.neuropsychologia.2009.11.022>
- Fink, A., Weiss, E.M., Schwarzl, U., Weber, H., de Assuncao, V.L., Rominger, C., Schuler, G., Lackner, H.K., Papousek, I., (2017). Creative ways to well-being: Reappraisal inventiveness in the context of anger-evoking situations, *Cognitive*

- Affective Behavioral Neurosciences* 17, 94–105. <https://doi.org/10.3758/s13415-016-0465-9>
- Ford, B. Q., Karnilowicz, H. R., & Mauss, I. B. (2017). Understanding reappraisal as a multicomponent process: The psychological health benefits of attempting to use reappraisal depend on reappraisal success. *Emotion*, 17(6), 905–911. <https://doi.org/10.1037/emo0000310>
- Ford, B. Q., Lwi, S. J., Gentzler, A. L., Hankin, B., & Mauss, I. B. (2018). The cost of believing emotions are uncontrollable: Youths' beliefs about emotion predict emotion regulation and depressive symptoms. *Journal of Experimental Psychology: General*, 147(8), 1170–1190. <https://doi.org/10.1037/xge0000396>
- Ford, B. Q., & Troy, A. S. (2019). Reappraisal Reconsidered: A Closer Look at the Costs of an Acclaimed Emotion-Regulation Strategy. *Current Directions in Psychological Science*, 28(2), 195–203. <https://doi.org/10.1177/0963721419827526>
- Foti, D., and Hajcak, G. (2009). Depression and reduced sensitivity to non-rewards versus rewards: evidence from event-related potentials. *Biol. Psychol.* 81, 1–8. doi: 10.1016/j.biopsycho.2008.12.004
- Füstös, J., Gramann, K., Herbert, B.M., Pollatos, O. (2013) On the embodiment of emotion regulation: interoceptive awareness facilitates reappraisal. *Social Cognitive and Affective Neuroscience*. 8(8), 911-7. doi: <https://doi.org/10.1093/scan/nss089>
- Garland, E.L., Hanley, A.W., Goldin, P.R., Gross, J.J. (2017). Testing the mindfulness-to-meaning theory: Evidence for mindful positive emotion regulation from a reanalysis of longitudinal data. *PLoS ONE* 12(12) e0187727. <https://doi.org/10.1371/journal.pone.0187727>
- Hajcak, G., MacNamara, A., and Olvet, D. M. (2010). Event-related potentials, emotion, and emotion regulation: an integrative review. *Dev. Neuropsychol.* 35, 129–155. doi: 10.1080/87565640903526504
- Hanley, A. W., de Vibe, M., Solhaug, I., Farb, N., Goldin, P.R., Gross, J.J., Garland, E.L. (2021). Modeling the mindfulness-to-meaning theory's mindful reappraisal hypothesis: replication with longitudinal data from a randomized controlled study. *Stress Health* 37, 778–789. doi: <https://doi.org/10.1002/smi.3035>
- Hennink, M., Kaiser, B. N. (2022). Sample sizes for saturation in qualitative research: A systematic review of empirical tests, *Social Science & Medicine*, 292, 114523, <https://doi.org/10.1016/j.socscimed.2021.114523>.
- Kamburidis, J. A. (2024). Alexithymia with Emotion Regulation Strategies and Mental Health in Schizophrenic Patients. *Journal of Evidence-Based Psychotherapies*, 24(1), 109-116.
- Kollias, D., Tzirakis, P., Nicolaou, M.A., Papaioannou, A., Zhao, G., Shuller, B., Kotsia, I., Zafeririou, S. (2019) Deep Affect Prediction in-the-Wild: Aff-Wild Database and Challenge, Deep Architectures, and Beyond. *International*

- Journal Computer Vision* 127, 907–929. <https://doi.org/10.1007/s11263-019-01158-4>
- Koob, G. F., and Le Moal, M. (2001). Drug addiction, dysregulation of reward, and allostasis. *Neuropsychopharmacology* 24, 97–129. doi: 10.1016/S0893-133X(00)00195-0
- Koenigsberg, H. W., Fan, J., Ochsner, K. N., Liu, X., Guise, K., Pizzarello, S., . . . Siever, L. J. (2010). Neural correlates of using distancing to regulate emotional responses to social situations. *Neuropsychologia*, 48, 1813–1822. doi:10.1016/j.neuropsychologia.2010.03.002
- Lennarz, H. K., Hollenstein, T., Lichtwarck-Aschoff, A., Kuntsche, E., & Granic, I. (2018). Emotion regulation in action. *International Journal of Behavioral Development*, 016502541875554. doi:10.1177/0165025418755540
- Marchewka A., Żurawski Ł., Jednoróg K., Grabowska A. (2014) The Nencki Affective Picture System (NAPS): introduction to a novel, standardized, wide-range, high-quality, realistic picture database. *Behavior Research Methods*, 46(2), 596–610. <https://doi.org/10.3758/s13428-013-0379-1>
- McRae, K., Ciesielski, B., Gross, J.J. (2012) Unpacking Cognitive Reappraisal: Goals, Tactics and Outcomes. *Emotion*, 12(2), 250-255. <https://doi.org/10.1037/a0026351>
- Newman, D. B., & Nezlek, J. B. (2022). The Influence of Daily Events on Emotion Regulation and Well-Being in Daily Life. *Personality and Social Psychology Bulletin*, 48(1), 19–33. <https://doi.org/10.1177/0146167220980882>
- Nook, E. C., Vidal Bustamante, C. M., Cho, H. Y., & Somerville, L. H. (2020). Use of linguistic distancing and cognitive reappraisal strategies during emotion regulation in children, adolescents, and young adults. *Emotion*, 20(4), 525–540. <https://doi.org/10.1037/emo0000570>
- Ochsner, K. N., and Gross, J. J. (2008). Cognitive emotion regulation insights from social cognitive and affective neuroscience. *Curr. Dir. Psychol. Sci.* 17, 153–158. doi: 10.1111/j.1467-8721.2008.00566.x
- Ochsner, K. N., Ray, R. D., Cooper, J. C., Robertson, E. R., Chopra, S., Gabrieli, J. D. E., & Gross, J. J. (2004). For better or for worse: Neural systems supporting the cognitive down- and up-regulation of negative emotion. *NeuroImage*, 23, 483–499. <https://doi.org/10.1016/j.neuroimage.2004.06.030>
- Or Cohen Ben Simon, Lior Ron & Shimrit Daches (2022) Successful implementation of cognitive reappraisal: effects of habit and situational factors, *Cognition and Emotion*, 36:8, 1605-1612, DOI: 10.1080/02699931.2022.2138831
- Papousek, I., Rominger, C., Weiss, E.M. *et al.*, (2019) Humor creation during efforts to find humorous cognitive reappraisals of threatening situations. *Current Psychology*. <https://doi.org/10.1007/s12144-019-00296-9>
- Perchtold CM, Weiss EM, Rominger C, Feyaerts K, Ruch W, Fink A, et al., (2019) Humorous cognitive reappraisal: More benign humour and less "dark" humour

- is affiliated with more adaptive cognitive reappraisal strategies. *PLoS ONE* 14(1): e0211618. <https://doi.org/10.1371/journal.pone.0211618>
- Pavlov, S. V., Reva, N. V., Loktev, K. V., Tummyalis, A. V., Korenyok, V. V., and Aftanas, L. I. (2014). The temporal dynamics of cognitive reappraisal: cardiovascular consequences of downregulation of negative emotion and upregulation of positive emotion. *Psychophysiology* 51, 178–186. doi: 10.1111/psyp.12159
- Riegel, M., Żurawski, Ł., Wierzba, M., Moslehi A., Klocek L., Horvat M., Grabowska A., Michałowski J., Jednoróg K., Marchewka K., (2016) Characterization of the Nencki Affective Picture System by discrete emotional categories (NAPS BE). *Behaviour Research Method* 48, 600–612. <https://doi.org/10.3758/s13428-015-0620-1>
- Sai, L., Wang, S., Ward, A., Ku, Y., Sang, B., (2015) Individual differences in the habitual use of cognitive reappraisal predict the reward-related processing. *Frontiers Psychology*. Sep 1(6) 1256. doi: 10.3389/fpsyg.2015.01256.
- Schiffstein, H. N. J. (2009). Comparing Mental Imagery across the Sensory Modalities. *Imagination, Cognition and Personality*, 28(4), 371–388. <https://doi.org/10.2190/IC.28.4.g>
- Scult, M.A., Knodt, A.R., Swartz, J.R., Brigidu, B.D., Hariri, A.R. (2016) Thinking and Feeling: Individual Differences in Habitual Emotions Regulation and Stress-Related Mood Are Associated with Prefrontal Executive Control, *Clinical Psychology Science*, 1-8, <https://doi.org/10.1177/2167702616654688>
- Sheppes, G., Schiebe, S., Suri, G., Radu, P., Blechert, J., Gross, J.J., (2012) Emotional Regulatory Choice: A conceptual Framework and Supporting Evidence. *Journal of experimental psychology: general*, 143(1), 163-181. <https://doi.org/10.1037/a0030831>
- Sheppes, G., Gross, J.J. (2010) Is Timing Everything? Temporal Considerations in Emotional Regulation. *Personality and Social Psychology Review*, XX(X), 1-13. <http://doi.org/10.1177/1088868310395778>
- Verduyn P, Delvaux E, Van Coillie H, Tuerlinckx F, Van Mechelen I (2009) Predicting the duration of emotional experience: Two experience sampling studies. *Emotion* 9: 83–91. Doi/10.1037/a0014610
- Verduyn P, Van Mechelen I, Tuerlinckx F, Meers K, Van Coillie H (2009) Intensity profiles of emotional experience over time. *Cognit Emot* 23: 1427–1443. Doi/10.1037/a0014610
- Verduyn P, Van Mechelen I, Kross E, Chezzi C, Van Bever F (2012) The relationship between self-distancing and the duration of negative and positive emotional experiences in daily life. *Emotion* 12: 1248–1263. Doi/10.1037/a0028289
- Verduyn P, Van Mechelen I, Frederix E (2012) Determinants of the shape of emotion intensity profiles. *Cogn Emot* 26: 1486–1495. Doi/10.1080/02699931.2012.662152

- Wang YM, Chen J and Han BY (2017) The Effects of Cognitive Reappraisal and Expressive Suppression on Memory of Emotional Pictures. *Frontiers in Psychology* 8:1921. <https://doi.org/10.3389/fpsyg.2017.01921>
- Wang YX, and Yin B (2023) A new understanding of the cognitive reappraisal technique: an extension based on the schema theory. *Front. Behav. Neurosci.* 17:1174585. doi: 10.3389/fnbeh.2023.1174585
- Weber, H., Loureiro de Assunção, V., Martin, C., Westmeyer, H., & Geisler, F. C. (2013). Reappraisal inventiveness: The ability to create different reappraisals of critical situations. *Cognition & Emotion*, 28, 345–360. <https://doi.org/10.1080/02699931.2013.832152>
- Webb, T.L., Miles, E., Sheeran, p. (2012) Dealing with Feeling: A Meta-Analysis of the Effectiveness of Strategies Derived from the Process Model of Emotion Regulation, *Psychological Bulletin*, 138(4), 775-808. <https://doi.org/10.1037/a0027600>
- Zeier, P., Sandner, M., & Wessa, M. (2019). Script-based Reappraisal Test introducing a new paradigm to investigate the effect of reappraisal inventiveness on reappraisal effectiveness. *Cognition and Emotion*, 34(4), 793–799. <https://doi.org/10.1080/02699931.2019.1663153>

## Appendix A

### 1. Emotional focused reappraisal

- 1.1. **Positive self-assessment, self-motivation** - an emotion orientated reappraisal strategy that is focused on self-validation, which could bring benefits in the shape of (a) motivation, and (b) act as support to enhance the process of self-regulation through other reappraisal strategies.
- 1.2. **Negation or diminishing probability** - a reappraisal strategy that questions the reality of an experienced event or minimizes the likelihood of risks or consequences that could happen. Affirmations like: *"It can't happen to me"*, best describe this strategy.
- 1.3. **Positive thinking** - a positive interpretation of an expected outcome, often without a relying on facts or on realistic information. Affirmations like: *"Everything will be all-right"*, describe this strategy best.
- 1.4. **Diminution of negative evaluation** - reappraisals that include humour, empathy, and other changes in point of view regarding a specific stressful event that contributes to a change in the perceived negativity of the short and long term consequences of the experienced event.

### 2. Reality Focused Reappraisal

- 2.1. **Importance assessment and prioritization** - a reappraisal strategy that subjects use as a way of reminding themselves to find solutions to specific problems. It can be seen as a part of Technical–Analytic–Problem Solving reappraisal tactic, McRae et al., (2012). It can be seen as a strategy that self-regulates the reappraisal process.
- 2.2. **Responsibility assumption** - a strategy in which the participants recognise their own contribution to the unwanted outcome of a stressful situation.
- 2.3. **Justification** - a strategy in which the subjects search for acceptable excuses that could help them to minimize the unwanted behavior of others.
- 2.4. **Compensation** - reappraisal strategies where the subjects identify a potential chance to improve or engage in self-development through the experienced situation. This strategy differs from positive thinking by focusing on potential future actions or opportunities, and bears more resemblance to McRae et al's., (2012) changing current or future circumstance. Affirmations like: *"No problem that my friend didn't water my plants, at least I know who I can trust"*, best describes this strategy.
- 2.5. **Normality check** - subjects try to compare the experienced situation to a social or outside norm, in order to establish the normality or the degree to which some specific behavior could be accepted as normal or realistic. This type of strategy is sometimes included in the acceptance category by researchers.
- 2.6. **Acceptance** - a reappraisal strategy focused on taking the experience as it is in situations that are perceived as being outside of one's own control. This reappraisal strategy is not usually associated with any additional conclusions, such as

justification, compensation or similar strategies. Affirmations like: “*This is the situation and I can live with it*”, best describe this strategy.

- 2.7. **Solution formulations** - reappraisal strategies focused on practical actions and behavior that can be made in order to change the consequences of emotion eliciting events. This category is similar to Technical–Analytic–Problem Solving reappraisal tactic, McRae et al., (2012).

---

## PSYCHOMETRIC PROPERTIES AND FACTOR STRUCTURE OF THE DISGUST SCALE-REVISED (DS-R) FOR THE ROMANIAN POPULATION

---

*Simona A. Pascal\**

Laboratory of Cognitive Clinical Sciences, University of Bucharest, Bucharest, Romania

---

### Abstract

Research on measuring the intensity of disgust has required the development of instruments to measure this construct. Given that, a more culturally appropriate scale is needed to ensure a valid and reliable measurement of disgust. The concept of “disgust” does not have an appropriate literature in Romanian pathology, and Disgust Scale-Revised (DS-R) is quite rarely used in the public health context. Therefore, this study focuses on the psychometric properties of the Romanian adaptation of the DS-R, one of the preferred instruments for measuring disgust. More specifically, the research investigated different forms of reliability and validity of the DS-R, using both Classical Test Theory (CTT) and Item Response Theory (IRT) analysis approaches. In general, the results showed good fidelity, fit of the single-factor model of the DS-R, good convergent and divergent validity with respect to the relationships of this scale with other variables. The study also highlights the important role of disgust and anxiety in predicting obsessive-compulsive symptoms. In conclusion, further refinement of the scale could be useful for a more comprehensive development of this instrument in the clinical setting.

**Keywords:** disgust, scale adaptation, item response theory, confirmatory factor analysis, incremental validity.

One of the least studied emotions, disgust, gets an increasing interest in the literature. Empirical studies published on this topic have shown that this emotion is involved in various anxiety psychopathologies, such as animal and spider phobias (Bianchi & Carter, 2012; Olatunji & Deacon, 2008), blood-injection-injury phobia (Gilchrist et al., 2016; Olatunji et al., 2006), health anxiety (Brand et al., 2013; Fan

---

\* Correspondence concerning this article should be addressed to Simona A. Pascal, Laboratory of Cognitive Clinical Sciences, University of Bucharest, Bucharest, Romania.  
E-mail: alexandra-simona.pascal@fpse.unibuc.ro

& Olatunji, 2013), obsessive-compulsive disorder (Armstrong & Olatunji, 2017; Cervin & Perrin, 2019; Olatunji, Berg, et al., 2017), posttraumatic stress disorder (Badour & Feldner, 2016; Brake et al., 2017), and eating disorders (Anderson et al., 2018; Khairallah et al., 2019; Olatunji, 2019). From a pathological point of view, disgust may therefore contribute to the development and maintenance of both anxiety and related clinical manifestations from the earliest years of life (Muris, 2006). In relation to anxiety disorders, the available empirical research suggested that disgust mediates the relationship between negative affect and specific symptoms of spider phobia and blood-injection-injury phobia, but only partially in the case of fear of contamination. Disgust may also contribute to the development of anxiety concerns through performance and attention biases or fear of contagion (Olatunji et al., 2010).

In the case of obsessive-compulsive disorder (OCD), the common concern of people diagnosed with this disorder was fear of contamination (Knowles, Tomarken, et al., 2018). On the one hand, these people evaluated themselves negatively in terms of personal hygiene as part of their obsessions and believed that they were spreading germs; on the other hand, their compulsions related to personal hygiene and the cleaning of objects made the sufferers extremely stressed. In addition, people with OCD often tend to avoid situations in which they might contaminate themselves (Rachman, 2004). Thus, empirical research highlighted that while concern about contamination is traditionally guided by fear, disgust may be a more relevant emotion in this clinical disorder (Knowles, Cox, et al., 2018). Both self-reported data and neurobiological studies have proven a connection between disgust and fear of contamination (Deacon & Olatunji, 2007; Olatunji et al., 2004). Specifically, viewing disgusting images increased insula activity in people with OCD, as this region is involved in disgust (Shapira et al., 2003). Theoretical models have suggested that this emotion is an active variable in the development of OCD and reinforces the causes of avoidance of the disorder (Olatunji, Ebesutani, et al., 2011; Olatunji, Tart, et al., 2011). Similarly, research has shown that the experience of disgust contributes to the development of fear-related beliefs and subsequent avoidance behaviour as early as adolescence (Muris et al., 2009).

Research on the intensity of disgust required the development of instruments to measure this construct. The scales were developed according to the two-factor model, which describes two types of disgust, core and animal. While core disgust is based on unpleasantness and the risk of contamination, animal-reminder disgust reflects aversion to stimuli that are reminiscent of the animal origins of humans. The bifactorial model of disgust was found to be more appropriate than a unitary model of disgust (Olatunji et al., 2005). Other studies have also helped to support the usefulness of the two-factor model. For example, fear of animals and contamination-based obsessive-compulsive disorder appear to be specifically related to core disgust, while fear of blood-injection-injury has been linked to animal-reminder disgust (De Jong & Merckelbach, 1998; Olatunji et al., 2005).

The first instrument to measure this concept is the Disgust and Contamination Sensitivity Questionnaire (DQ; Rozin et al., 1984). Originally, the DQ was developed to identify similarities and differences between children and parents in their attitudes towards certain foods. It was later used to measure disgust sensitivity. The original form of the questionnaire included the following three sections: food area, disgust sensitivity and other aspects (e.g., culinary knowledge). The validity of this instrument was limited to the relationship between disgust and specific phobias (Merckelbach et al., 1999; Mulkens et al., 1996). In addition, Arrindell et al. (1999) considered that the DQ was limited to aspects of food consumption. However, the stimuli that trigger disgust include more than food and its rejection (Olatunji & Sawchuk, 2005). This diversity of stimuli has led to the argument that disgust is not a unitary construct (Olatunji et al., 2004). So, a multidimensional approach to this concept can thus lead to the development of more comprehensive and heterogeneous self-assessment tools (Olatunji & Sawchuk, 2005).

More recently, the Disgust Emotion Scale (DES; Kleinknecht et al., 1997) has been introduced as an alternative measure of disgust intensity in several domains: animals, injections and blood draws, mutilation and death, rotting foods and odours. Kleinknecht et al. (1997) used a structural equation model to show that fear of blood-injection-injury was positively related to fainting that occurred during the last exposure to injections and blood. Thus, disgust showed a positive relationship with fear of these elements. In addition, the researchers felt that the instrument would allow for more accurate identification of individual differences related to this emotion (Olatunji & McKay, 2009).

The Three Domains of Disgust Scale (TDDS; Tybur et al., 2009) is another instrument that measures three types of disgust reported in the literature, namely pathogenic, moral, and sexual disgust. The pathogenic dimension has been associated with self-reported obsessive-compulsive symptoms (Olatunji et al., 2015). In addition, an increased predisposition to sexual disgust in mothers has been associated with a high risk of developing post-traumatic stress disorder in individuals with sexually abused children (Van Delft et al., 2016). This scale includes 21 items measured on a Likert scale with response options ranging from *not at all disgusting* (0) to *extremely disgusting* (6). The literature suggests that the instrument has the following two important limitations: (1) there is a conceptual overlap with anxiety in that it contains items similar to those used to measure animal phobias or obsessive-compulsive disorder (e.g., the item "*Seeing a cockroach walk across the floor*"), and (2) it does not distinguish between different types of relevant pathogens (De Jong & Borg, 2020).

Another instrument used to measure disgust is the Disgust Propensity and Sensitivity Scale (DPSS; Cavanagh & Davey, 2000). More specifically, this measures individual differences in the propensity to experience disgust, regardless of the agents involved (De Jong & Borg, 2020). The scale includes 32 items

measured on a Likert scale with five response options ranging from *never* (1) to *always* (5). The instrument is also available in two revised versions, one containing 16 items (DPSS-R; Van Overveld et al., 2006), and the second containing 12 items (DPSS-R; Fergus & Valentiner, 2009), based on the psychometric properties of the scale. The current version has predictive value for avoidance behaviour and psychopathology (Engelhard, et al., 2011; Van Overveld et al., 2010). In addition, the DPSS-R is useful for assessing disgust sensitivity in various mental disorders. However, Olatunji & McKay (2009) pointed out that the items of this instrument need to be restructured, especially regarding their cultural stability.

The most commonly used measure of disgust in the contemporary empirical literature is the Disgust Scale (DS; Haidt et al., 1994). It assesses the intensity of disgust responses in the following domains: animals, body products, death, food, hygiene, and sex. DS contains 32 statements divided into two main sections: (1) an assessment of avoidance behaviours and emotional responses to potentially disgusting stimuli and (2) the severity of disgust when exposed to specific scenarios. For this instrument, Haidt et al. (1997) described a latent structure with eight factors (food, animals, body products, sex, body envelope violations, death, hygiene, and sympathetic magic). In this case, inadequate estimates of internal consistency were found (Olatunji & McKay, 2009). Therefore, DS was not psychometrically assessed. Furthermore, Olatunji, Sawchuk et al. (2007) conducted four research studies that identified the psychometric limitations of the instrument and revised it by removing seven items. The final product of these studies was the revised version of the instrument.

The Disgust Scale-Revised (DS-R; Olatunji, Williams, et al., 2007) is the most widely used instrument to assess the experience of disgust (De Jong & Borg, 2020). It was developed to measure individual differences in the extent of disgust experienced in everyday life (Olatunji & Sawchuk, 2005). The assessment instrument includes the following three dimensions of disgust, which have been transformed into subscales: core disgust (based on an offensive nature and threat of disease consisting of stimuli such as spoiled food, garbage, and small animals), animal-reminder disgust (reflecting aversion to stimuli that serve as reminders of human animal origins), and contamination-based disgust (includes specific responses based on the perceived threat of contagion). This version contains 25 items, of which the first 13 statements have dichotomous response options of *false* (0) and *true* (1), and the following 12 items provide response options on a Likert scale, ranging from *not disgusting* (0), *slightly disgusting* (0.50) to *very disgusting* (1). DS-R has been used in subclinical (Olatunji et al., 2004), clinical (Woody & Tolin, 2002), and cultural settings (Olatunji et al., 2006). Both DS and DS-R have been used in studies investigating the association between an increased predisposition to disgust and certain clinical anxiety symptoms. More specifically, they indicated that while core and contamination-related disgust were related to obsessive-compulsive symptoms (Olatunji, Williams, et al., 2007), blood-injection-

injury phobia was associated with disgust reminiscent of animal nature (De Jong & Merckelbach, 1998). Although this scale has been widely used and has important features, it is necessary to mention its two main limitations. The first one pointed out that half of the items in the instrument contain statements about avoidance of certain stimuli or behaviours that do not explicitly refer to disgust (e.g., the statement “*I might be willing to try eating monkey meat, under some circumstances.*”). The second important limitation concerns conceptual overlap with anxiety (e.g. the statement “*I never let any part of my body touch the toilet seat in a public washroom.*”; De Jong & Borg, 2020).

DS-R has been adapted for use in several cultures, including Australia, Brazil, Germany, Italy, Japan, the Netherlands, Sweden, and the United States with non-clinical populations (Olatunji et al., 2009; Van Overveld et al., 2011), Iran with obsessive-compulsive disorder populations (Shams et al., 2015), Korea with non-clinical populations (In Kang et al., 2012), and Ghana (Skolnick & Dzokoto, 2013), respectively. This disgust assessment instrument had good internal consistency across adjustments, with Cronbach's Alpha coefficients ranging from .68 to .87. The English (Van Overveld et al., 2011) and Korean (In Kang et al., 2012) versions had the highest internal consistency coefficient values, while the cross-cultural studies had the lowest values (Olatunji et al., 2009; Skolnick & Dzokoto, 2013). In addition, these studies conducted confirmatory factor analyses for this instrument. The following models were tested: one-factor model, three-factor model (Olatunji et al., 2009; Olatunji, Williams, et al., 2007), and five-factor model (In Kang et al., 2012). The results obtained by these authors at the level of incremental indicators, residuals, and approximation error, highlighted the fit of the models to the population covariance matrix.

With the tools available to assess disgust, research directions have focused on determining the role of this emotion in various mental disorders. For example, previous studies have used structural equation models of disgust in anxiety and obsessive-compulsive psychopathology. The number of these studies is limited, but the main results are presented below. Regarding anxiety symptoms, clinical manifestations of blood-injection-injury phobia were positively associated with fainting symptoms, whereas experiences of disgust were negatively associated with them (Kleinknecht et al., 1997).

In relation to obsessive-compulsive symptoms, negative affect (anxiety, neuro-vegetative symptoms, mood) and disgust predicted their severity (Olatunji, Ebesutani, et al., 2017). Moreover, pathogenic disgust was the only predictor of contamination after the contact with an object, while sexual disgust was a predictor of fear of psychological contamination after controlling for anxiety and depression (Poli et al., 2019). Disgust proneness was associated with avoidance behaviours. Furthermore, emotion as a condition mediated the effects of disgust proneness on avoidance behaviour. These data have implications for the aetiology of contamination-related OCD.

Experiences perceived as unfair and obsessive beliefs have been associated with psychological symptom severity. While these experiences were associated with core dimensions of OCD (checking, washing, compulsivity, ordering, and psychological neutralisation), predisposition to disgust was associated with obsessive manifestations and, negatively, with psychological neutralisation. Moreover, unfair experiences and levels of dissatisfaction partially mediated the overall effect of disgust in the case of fear of contamination. Thus, sensitivity to sensory phenomena was the mechanism that partially explained why disgust may lead to contamination and washing behaviours (Olafsson et al., 2020). From a longitudinal perspective, baseline levels of disgust susceptibility were found to be associated with higher levels of obsessive-compulsive symptoms when levels of depression were controlled. Thus, although disgust proneness may be concurrently associated with obsessive-compulsive symptoms, the possible associations are specific to the subtype of contamination or washout (Olatunji, Kim, et al., 2019). This information underscores the importance of analysing vulnerability factors to better understand OCD, as well as the strong association between OCD symptoms (especially cleaning symptoms) and disgust proneness (Melli et al., 2019).

Thus, there is a need for a valid and accurate instrument to measure disgust with the main goal of identifying individuals with elevated levels who may be at risk when clinical symptoms are also present. Such an instrument is necessary to assist and intervene in cases to achieve adaptive management of situations. Identifying individuals with high disgust scores as part of anxiety and obsessive-compulsive symptoms also allows clinical psychologists to adapt and personalize the psychological strategies and approaches used in these cases.

#### *Purpose of the present study*

If disgust contributes to the development of contamination fears, it may also be influenced by avoidance of phobic stimuli (Olatunji et al., 2008). Therefore, incorporating psychological interventions that assess both fear/anxiety and disgust in the context of anxiety disorders may result in more consistent treatment effects (Cisler et al., 2009). In addition, measuring disgust levels is critical to managing the various psychological symptoms elicited, as early detection can lead to the development of an effective psychological intervention strategy to reduce clinical manifestations. Therefore, the study was designed to evaluate the psychometric properties of the DS -R by applying a series of approaches typical of both Classical Test Theory and Item Response Theory on a data set from the Romanian population.

As a first study conducted with the revised version of this scale (Olatunji et al., 2007), as well as other validation studies (In Kang et al., 2012; Olatunji et al., 2009; Shams et al., 2015; Skolnick & Dzokoto, 2013; Van Overveld et al., 2011), the main objective of this research was to analyse the factor structure of the DS-R, its fidelity and validity (convergent and discriminant) for a Romanian non-clinical

sample. This objective was formulated because disgust is studied less in Romanian pathology and DS-R is quite rarely used in this context, although the emotion may represent a public health problem (Curtis et al., 2011). One of the reasons why French researchers and clinical practitioners have paid little attention to disgust is the lack of an official instrument to measure individual tendencies regarding specific disgust responses. Such a scale would allow analysing the role of disgust in specific relevant psychopathological conditions, thus verifying the applicability of scientific findings as proven in different cultural settings (Novara et al., 2019). Moreover, the validation of the Romanian version of DS-R may lead to the identification of new information about the analysed constructs, their applicability and the possibility of generalisation to the Romanian population.

In addition, this research aimed to identify specific predictors of obsessive-compulsive symptoms, a topic that may be useful in the field of clinical psychology and psychotherapy as therapists become more likely to be interested in new directions in treating people with fears of contamination (Poli et al., 2019). This goal was set because previous studies have focused solely on the internal structure of the instrument and neglected predictors of clinical symptoms when it came to disgust. Therefore, adapting an instrument to assess this emotion to the Romanian population is necessary because it allows both the study of the specific characteristics of disgust in Romania and the provision of information about the common cross-cultural components of the emotion. Furthermore, all analyses were applied to data derived from a less studied Eastern European culture.

## **Method**

### *Sample*

The convenience sample consisted of 480 people, of whom 371 were female (77.30%). The age of the participants ranged from 18 to 88 years ( $M = 25.63$ ,  $SD = 8.99$ ). Of the total number of persons, 222 people (46.30%) were employed. Regarding the place of residence, 399 participants (83.10%) lived in urban areas. In terms of last completed education level, 274 people (57.10%) had a high school degree, 117 participants (24.40%) attended a university at the bachelor's level, and 64 people (13.30%) held a university degree at the master's level. Further details can be found in Table 1.

The inclusion criteria for participants in this study consisted of the following three key aspects: (1) a minimum age of 18 years; (2) they spoke Romanian; and (3) they participated in all phases of the study and filled in all

responses to the items on the measurement instruments. There were no other restrictions related to demographic characteristics.

**Table 1.** Demographic data of the sample

Demographic feature	Results ( <i>N</i> = 480)
Residence	
rural	81 (16.90%)
urban	399 (83.10%)
Ethnicity	
Romanian	472 (98.30%)
Tatar	2 (0.40%)
Polish	1 (0.20%)
Others	5 (1.00%)
Civil status	
single	242 (50.40%)
cohabitation	115 (24.00%)
married	72 (15.00%)
divorced	12 (2.50%)
widowed	2 (0.40%)
in a stable relationship	37 (7.70%)
Education level (last completed)	
gymnasium	1 (0.20%)
high school	274 (57.10%)
technical education	21 (4.40%)
faculty-bachelor	117 (24.40%)
faculty-master	64 (13.30%)
doctoral school	3 (0.60%)
Current academic status	
faculty-bachelor	364 (75.80%)
faculty-master	57 (11.90%)
doctoral school	7 (1.50%)
another academic status	52 (10.80%)
Current professional status	
employed	222 (46.30%)
unemployed	256 (53.30%)
retired	2 (0.40%)

### *Variables measured and instruments used*

The variables included in this study were disgust, anxiety, depression, perceived stress, and obsessive-compulsive symptoms. These were measured with self-report instruments. In order to study the two main objectives, the variables chosen by the authors of the other previously published studies that adapted the same scales were carefully analysed (In Kang et al., 2012; Olatunji et al., 2007, Shams et al., 2015; Skoknick & Dzokoto, 2013) and finally, instruments measuring similar variables were selected. In addition, they had to be adapted according to the objectives set. The variables and assessment instruments are explained in more detail below.

Disgust was measured using the Disgust Scale-Revised (DS-R; Olatunji et al., 2007). The instrument measures the degree of this emotion in various everyday situations. This scale contains 25 items, of which the first 13 statements have dichotomous response options of *false* (0) and *true* (1), and the following 12 items represent response options on a Likert scale, ranging from *not disgusting* (0), *slightly disgusting* (0.50) to *very disgusting* (1). For example, one of the statements is „*It would bother me tremendously to touch a dead body.*” Items 1, 3, and 7 were reversed and the scores obtained for the items were then summed. For this sample, the internal consistency for DS-R was  $\alpha = .83$ .

The disgust variable was also measured with the Disgust Emotion Scale (DES; Olatunji, Sawchuk, et al., 2007). This instrument assesses the degree of disgust in specific situations that evoke levels of disgust, revulsion, or repugnance in some people based on five domains of disgust triggers (animals, injections and blood draws, mutilation and death, rotting food, and smells). DES includes 30 items; an example of the affirmations is “*Photos of wounded soldiers.*” The instrument uses Likert scale responses with options ranging from *no disgust or repugnance at all* (0) to *extreme disgust or repugnance* (4). The total score was determined by summing all 30 items. DES yielded an internal consistency of  $\alpha = .93$  for the present sample.

Anxiety was measured using the Beck Anxiety Inventory (BAI; Steer & Beck, 1997). This instrument measures the level of anxiety in the past month using 21 items. For example, one of the items is “*Fear of worst happening.*” The scale includes responses on a Likert scale ranging from *not at all* (0) to *severely-it bothered me a lot* (3). The total score is the sum of the responses given by each participant. BAI showed an internal consistency of  $\alpha = .86$  for this sample.

Depression was measured with Beck Depression Inventory (BDI; Beck et al., 1996). This instrument measures the level of depression in the past month using 21 groups of statements with four situations each. For example, one of the items is “*I feel sad.*” The scale uses four response options, coded 0 to 3 points depending on the severity of each item. The total score was obtained by summing all responses. BDI achieved an internal consistency of  $\alpha = .73$  in the present sample.

Perceived stress was measured using the Perceived Stress Scale (PSS; Cohen et al., 1983), which measures the amount of stress felt by the person in the past month. This scale includes 10 questions with response variations on a Likert scale from *never* (0) to *very often* (4). For example, one of the items is “*In the last month, how often have you been upset because of something that happened unexpectedly?*” Items 4, 5, 7, and 8 are reversed, and the scores obtained for the items were then summed. The PSS achieved an internal consistency of  $\alpha = .86$  for this sample.

Obsessive-compulsive symptoms were measured with The Obsessive-Compulsive Inventory-Revised (OCI-R; Foa et al., 2002). This instrument measures obsessive-compulsive symptoms using 18 statements. These relate to the experiences that people have in their daily lives. For example, one of the items is “*I get upset if others change the way I have arranged things.*” The instrument uses

responses on a Likert scale with response options ranging from *not at all* (0) to *extremely* (4). The total score was determined by summing all 18 items for each participant. The OCI-R had an internal consistency of  $\alpha = .65$  in the present sample.

### *Procedure*

Firstly, the DS-R and DES were translated from English using the traditional dyadic method to obtain the final form of the questionnaire. Secondly, the data for this research was collected through various social networks using Google Forms. Specifically, people were recruited both on university campus (advertising through various student networks) and online (through various social networks). All participants were part of this convenience sample. They provided information about their demographic data and filled out DS-R, DES, BAI, BDI, PSS, and OCI-R. As the assessment tools were administered online, it was not possible to fill in all the answers without providing all of them. Therefore, there was no missing information in the database.

All volunteers had to speak Romanian and be at least 18 years of old. These inclusion criteria were outlined at the beginning of the information material. In addition, best practices in research with human participants were followed. Each participant was given an informed consent form describing their rights and responsibilities, the use of data for research purposes and the right to refuse to participate or withdraw at any time. In this regard, participants could not access the actual survey without first agreeing to the conditions specified in the consent form.

### *Statistical approach*

Firstly, before the actual data analysis, from the collected information, responses that did not meet the research objectives, and duplicate responses were reviewed. Also, OCI-R scale scores were checked to identify those exceeding the cutoff points set by Foa et al. (2002) as at least 21 (no such cases were identified). Secondly, internal consistency, convergent, discriminant, and incremental validity were examined in this study. For this purpose, the fidelity of the entire DS -R and for each subscale (core disgust, animal-reminder disgust, and contamination-related disgust subscale) was measured. Convergent validity was estimated using simple correlations between the two scales measuring disgust, namely DS-R and DES. Discriminant validity was examined using the relationship between disgust scores (measured with DS-R) and anxiety (measured with BAI), depression (measured with BDI) and perceived stress (measured with PSS). Predictive and incremental validity were tested using multiple regression analysis. In this context, the fit of the measured model was analysed. It included the criterion defined by the obsessive-compulsive symptoms (measured with OCI-R) and the following predictors: disgust (measured with DS-R), anxiety (measured with BAI), and perceived stress (measured with PSS).

The application of multiple linear regression required the fulfilment of conditions for both the dependent and independent variables (Popa, 2010). In this regard, the statistical analyses were performed using IBM SPSS Statistics version 23.

Thirdly, the aim of the study was to test the one-factor, three-factor, and five-factor models for the DS-R that exist in the literature. For this purpose, a confirmatory factor analysis was performed using JASP, version 0.14.1.0 (Goss-Sampson, 2020). The fit of the measured model was analysed using the following indicators: comparative fit index (CFI), Tucker-Lewis's index (TLI), parsimony index (AIC), standardized root mean squared residual (SRMR), and the root mean square error of approximation (RMSEA). For the incremental CFI, values above .95 indicate a good fit (Hu & Bentler, 1999), and for the RMSEA and SRMR indicators, values below .08 indicate a good model fit (Browne & Cudeck, 1993; Hu & Bentler, 1999).

Finally, Item Response Theory parameters for disgust (measured with DS-R) were analysed using the *mirt* package (Chalmers, 2012) of the R software (R Core Team, 2016). Estimates of disgust levels were obtained using the Graded Response Model (Samejima, 1997) for polytomous items. These models examined the following two important aspects: (1) the discrimination parameter (slope) which indicates the strength of the association between the item and the latent construct and (2) the boundary parameter, which refers to the position of the item on the latent variable continuum.

## Results

### *Results of preliminary data*

To test the normality of the distribution of the variables included in this study, indicators of the shape of the distribution were analysed, namely the skewness and kurtosis indices. Thus, all variables met the condition of normality. Details of the indicators of the shape of distribution for the variables disgust (DS-R and DES), anxiety (BAI), obsessive-compulsive symptoms (OCI-R), perceived stress (PSS), and depression (BDI) are shown in Table 2. To test the homogeneity of the distribution of the variables, Levene's test was used, and all variables met the homogeneity condition ( $p > .05$ ). The descriptive statistics for each item of the DS-R instrument are shown in Table 3.

**Table 2.** Descriptive Statistics, Cronbach Alpha indices, and correlations between the variables included in the study ( $N = 480$ )

Instrument	1	2	3	4	5	6
1. DS-R	—	.75**	.02	-.10*	.14**	.20**
2. DES	.75**	—	.09*	-.08	.09*	.24**
3. BAI	.02	.09*	—	.54**	.26**	.28**

Instrument	1	2	3	4	5	6
4. BDI	-.10*	-.08	.54**	—	.53**	.19**
5. PSS	.14**	.09*	.26**	.53**	—	.25**
6. OCI-R	.20**	.24**	.28**	.19**	.25**	—
<i>M</i>	12.39	45.95	7.53	5.29	14.12	9.78
<i>SD</i>	4.52	20.94	6.48	4.60	6.21	5.25
Skewness	-0.16	0.19	0.91	0.84	0.04	.01
Kurtosis	-0.81	-0.52	0.16	0.10	-0.28	-1.07

Notes. BAI = Beck Anxiety Inventory; BDI = Beck Depression Inventory; DES = Disgust Emotion Scale; DS-R = Disgust Scale-Revised; PSS = Perceived Stress Scale; OCI-R = The Obsessive-Compulsive Inventory-Revised; M = mean; AS = standard deviation.

\* $p < .05$  and \*\*  $p < .01$ . Standard error for skewness values is 0.11 and for kurtosis it is 0.22.

Descriptive statistics for the DS-R items with a sample of 480 participants revealed a less symmetrical distribution of items. The majority ranged from -2 to +2 for the distributional shape indicators, although this was more pronounced for item 2 (kurtosis = -2.00), item 5 (kurtosis = -2.00), and item 9 (skewness = 2.09 and kurtosis = 2.36). The correlations between the study variables are shown in Table 2.

**Table 3.** Descriptive statistics for DS-R

Item	<i>M</i>	<i>SD</i>	Skewness	Kurtosis	Item-total correlations	Cronbach's Alpha if item deleted
DSR_1	0.65	0.48	-0.64	-1.60	0.25	0.83
DSR_2	0.51	0.50	-0.03	-2.00	0.39	0.83
DSR_3	0.60	0.49	-0.43	-1.82	0.33	0.83
DSR_4	0.17	0.38	1.73	1.01	0.27	0.83
DSR_5	0.49	0.50	0.02	-2.00	0.36	0.83
DSR_6	0.31	0.46	0.80	-1.36	0.34	0.83
DSR_7	0.66	0.47	-0.68	-1.54	0.41	0.83
DSR_8	0.60	0.49	-0.39	-1.85	0.48	0.82
DSR_9	0.14	0.35	2.09	2.36	0.33	0.83
DSR_10	0.70	0.46	-0.85	-1.28	0.26	0.83
DSR_11	0.22	0.42	1.32	-0.25	0.19	0.83
DSR_12	0.75	0.43	-1.15	-0.69	0.32	0.83
DSR_13	0.65	0.48	-0.64	-1.60	0.42	0.82
DSR_14	0.33	0.32	0.42	-0.69	0.37	0.83
DSR_15	0.60	0.33	-0.25	-0.76	0.34	0.83
DSR_16	0.73	0.35	-0.90	-0.47	0.51	0.82
DSR_17	0.60	0.36	-0.33	-1.05	0.45	0.82
DSR_18	0.60	0.30	-0.11	-0.43	0.51	0.82
DSR_19	0.77	0.33	-1.12	0.01	0.53	0.82
DSR_20	0.60	0.40	-0.36	-1.37	0.48	0.82
DSR_21	0.34	0.39	0.60	-1.11	0.58	0.82
DSR_22	0.13	0.24	1.57	1.54	0.35	0.83
DSR_23	0.72	0.34	-0.84	-0.46	0.41	0.83

Item	<i>M</i>	<i>SD</i>	Skewness	Kurtosis	Item-total correlations	Cronbach's Alpha if item deleted
DSR_24	0.17	0.28	1.37	0.92	0.31	0.83
DSR_25	0.33	0.38	0.64	-0.97	0.34	0.83

**Table 4.** Item parameters for DS-R items

Core disgust scale						
Item	<i>a</i> (ES)	<i>b1</i> (ES)	<i>b2</i> (ES)	$S\text{-}\chi^2$	$RMSEAS\text{-}\gamma^2$	<i>p</i>
DSR_1	0.56 (0.12)	-1.20 (0.30)	–	21.81	0.04	.058
DSR_2	1.19 (0.17)	-0.03 (0.10)	–	15.20	0.03	.174
DSR_3	1.15 (0.16)	-0.46 (0.11)	–	12.69	0.02	.314
DSR_4	0.89 (0.18)	2.02 (0.35)	–	10.05	0.01	.436
DSR_5	0.85 (0.14)	0.04 (0.12)	–	11.38	0.00	.497
DSR_12	0.72 (0.14)	-1.67 (0.31)	–	13.12	0.01	.361
DSR_14	1.19 (0.15)	-0.31 (0.10)	2.35 (0.26)	11.94	0.00	.850
DSR_15	0.96 (0.13)	-2.22 (0.28)	0.83 (0.15)	21.34	0.00	.497
DSR_16	1.82 (0.21)	-1.64 (0.15)	-0.25 (0.08)	16.86	0.00	.464
DSR_17	1.21 (0.15)	-1.56 (0.18)	0.52 (0.11)	16.64	0.00	.614
DSR_18	1.58 (0.19)	-1.90 (0.18)	0.80 (0.10)	23.86	0.03	.160
DSR_23	1.03 (0.14)	-2.44 (0.31)	-0.23 (0.11)	30.72	0.03	.102
Animal-reminder disgust scale						
Item	<i>a</i> (ES)	<i>b1</i> (ES)	<i>b2</i> (ES)	$S\text{-}\chi^2$	$RMSEAS\text{-}\gamma^2$	<i>p</i>
DSR_6	1.21 (0.18)	0.82 (0.13)	–	3.20	0.00	.867
DSR_7	1.44 (0.19)	-0.64 (0.10)	–	8.45	0.02	.294
DSR_8	2.14 (0.28)	-0.31 (0.08)	–	8.13	0.02	.229
DSR_9	1.38 (0.24)	1.74 (0.22)	–	12.12	0.05	.059
DSR_13	1.45 (0.19)	-0.60 (0.10)	–	7.73	0.01	.357
DSR_19	2.56 (0.34)	-1.57 (0.12)	-0.41 (0.07)	7.07	0.00	.529
DSR_20	1.30 (0.15)	-1.13 (0.14)	0.26 (0.10)	1.55	0.00	1.000
DSR_21	1.74 (0.20)	0.02 (0.08)	1.21 (0.12)	8.35	0.00	.681
Contamination-related disgust scale						
Item	<i>a</i> (ES)	<i>b1</i> (ES)	<i>b2</i> (ES)	$S\text{-}\chi^2$	$RMSEAS\text{-}\gamma^2$	<i>p</i>
DSR_10	0.47 (0.14)	-1.84 (0.54)	–	0.25	0.00	.969
DSR_11	0.70 (0.15)	1.94 (0.39)	–	4.85	0.00	.434
DSR_22	5.49 (2.74)	0.71 (0.07)	2.14 (0.18)	5.93	0.04	.115
DSR_24	2.30 (0.37)	0.66 (0.08)	2.20 (0.20)	4.23	0.00	.516
DSR_25	0.86 (0.14)	0.04 (0.12)	2.10 (0.32)	4.85	0.00	.563

Note. *a* = item discrimination; *b* = item boundary parameter.

### Item Response Theory analysis

Item Response Theory analysis was performed using the Graded Response Model (GRM). The item parameters for DS-R are shown in Table 5. More

specifically, the results showed that the slope parameters ( $a$ ) ranged from 0.56 to 1.82 for core disgust, from 1.21 to 2.56 for animal-reminder disgust, and from 0.47 to 5.49 for contamination-based disgust. All of these results represent moderate to very high discrimination coefficients. Thus, consistent with Hayes et al. (2000), the higher the values of this parameter, the better they are associated with items that are better able to discriminate between levels of contiguous features near the inflection point.

In general, the boundary parameters ( $b$ ) started from a low level to a very high level. More specifically, they ranged from -2.44 to 2.35 for core disgust, from -0.64 to 1.74 for animal-reminder disgust, and from -1.84 to 2.20 for contamination-based disgust. In terms of item-to-scale fit level, after Bonferroni correction, none of the 25 statements were statistically significant at a Type I error rate of .05. This aspect revealed an item agreement for the respective scales.

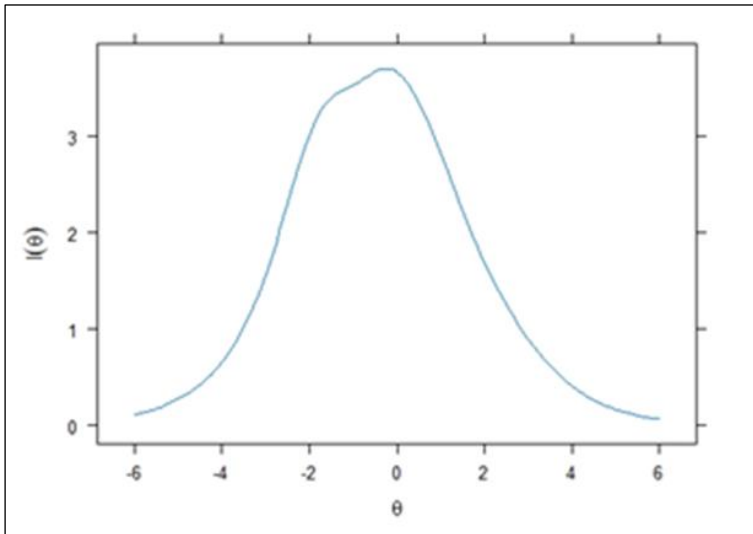

**Figure 1.** Information curve for core disgust scale

Given that the trait level must be  $bI > 0.00$  for the items to define the variable being measured, the results showed that the core disgust scale (12 affirmations) had only one item with a location parameter that was above 0 ( $bI > 0.00$ ) and two other items that approximated 0 (DSR\_2 and DSR\_5). For animal-reminder disgust (eight items), two items showed a value of  $bI > 0.00$  (DSR\_6 and DSR\_9) and item 21 was close to 0. For the last scale measuring contamination-based disgust (five affirmations), three items defined the measured variable (items 11, 22, and 24), while DSR\_25 showed a value close to 0. In terms of item endorsement, we obtained the following results ( $\theta$ ): approximately between -3.00 and 2.00 for core disgust (Figure

1), between -2.00 and 2.00 for animal-reminder disgust (Figure 2), and between 0.00 and 3.00 for contamination-based disgust (Figure 3).

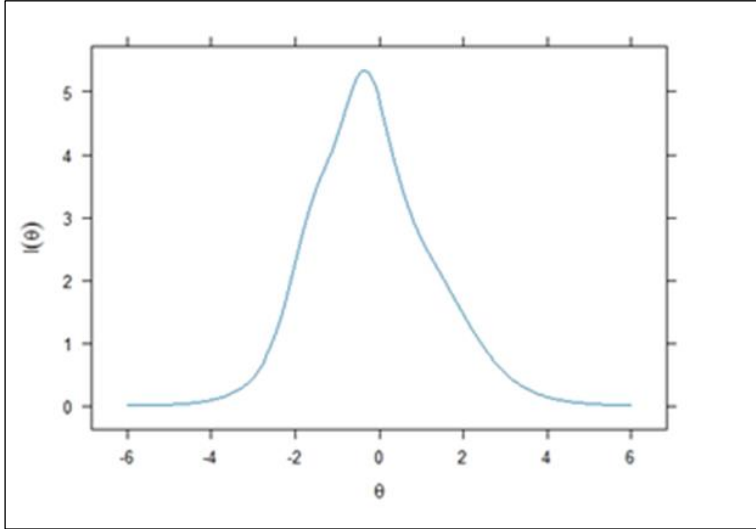

**Figure 2.** Information curve for animal-reminder disgust scale

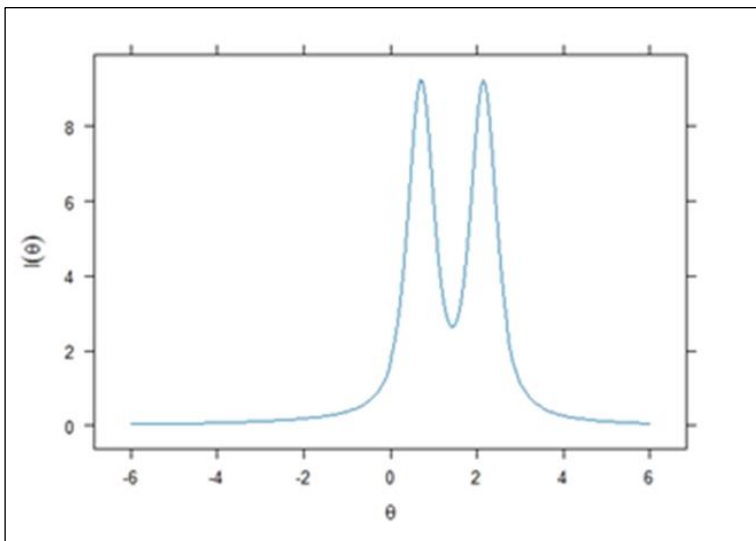

**Figure 3.** Information curve for contamination-based disgust

Analysis of the items for each scale revealed that the response categories for the following items were difficult to identify: item 19 and item 21 from the animal-

reminder disgust and item 22 from the contamination-based disgust. The item trace lines can be seen in Figures 4, 5, and 6.

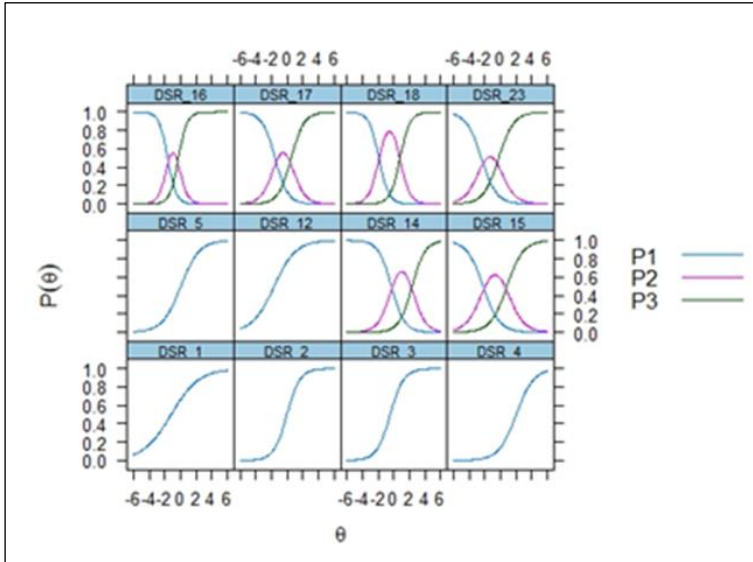

Figure 4. Item trace lines for core disgust scale

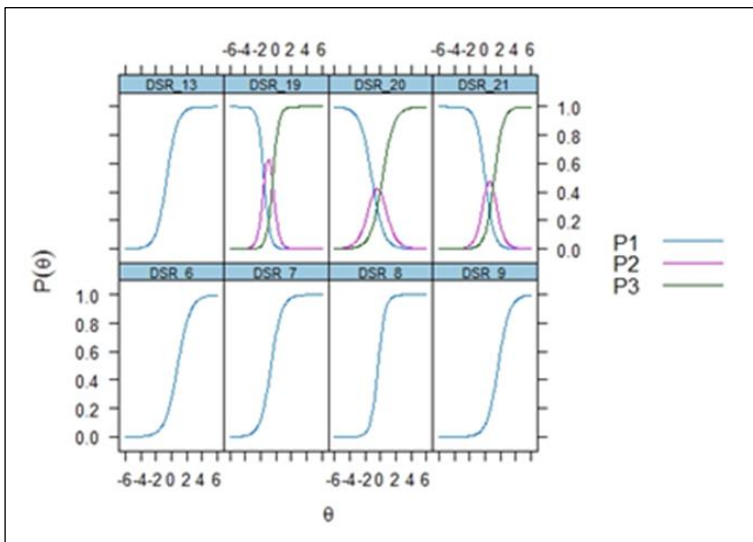
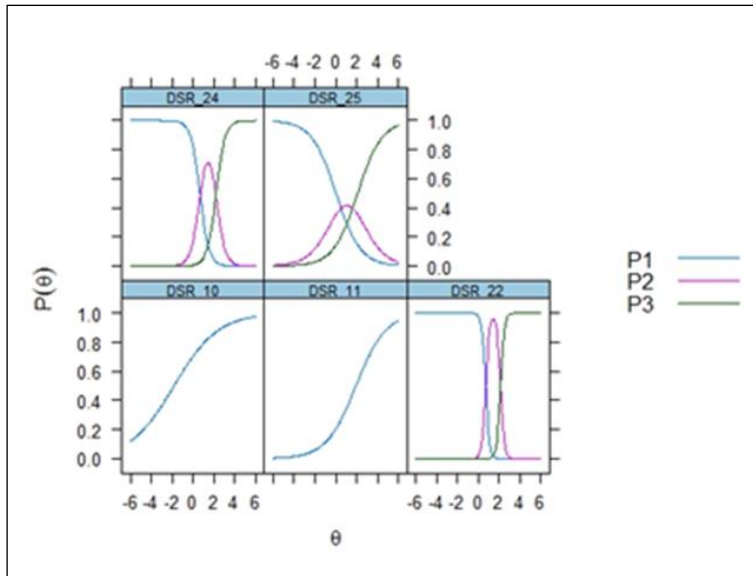

Figure 5. Item trace lines for animal-reminder disgust scale



**Figure 6.** Item trace lines for contamination-based disgust

Local dependency statistics were analysed using the  $LD-\chi^2$  index (Chen & Thissen, 1997) and with *Cramer V* values above 0.20 cut-off (Morizot et al., 2007) for all item pairs. For the core disgust scale, six item pairs had scores above 10 and 14 items had scores between 5 and 10. For the animal-reminder disgust scale, the pair of items 2 and 21 had scores above 10 and another pair had scores between 5 and 10. For the contamination-based disgust scale, one pair of items had scores above 10 and another pair had scores between 5 and 10. This problem made it clear that the assumption of local independence was violated. As for the *Cramer V* index, there were pairs of items that exceeded the value of 0.20, namely two pairs for the core disgust scale, 10 pairs in the case of animal-reminder disgust and four pairs in the contamination-based disgust subscale.

#### *Factorial structure of DS-R (Romanian version)*

The Keiser-Mayer-Olkin test for the 480 individuals and Bartlett's test were conducted to determine whether the characteristics of the data were appropriate for the factor analysis to be conducted. Thus, the Kaiser-Meyer-Olkin test yielded an index of 0.86 with Bartlett's test ( $\chi^2 = 2368.58$ ,  $df = 300$ ,  $p < .001$ ), suggesting the presence of one or more common factors. Thus, the use of factor reduction procedures was warranted. In addition, confirmatory factor analysis provided freedom for factors to be correlated or independent (Costello & Osborne, 2005; Wood et al., 2015).

The models tested were those identified in the literature, namely the one-factor model (Model 1), models number 2 and 3 which represented three factors, proposed by Olatunji et al. (2009) and by Olatunji, Williams, et al. (2007), and the five-factor model (Model 4), tested by In Kang et al. (2012). The results of the standardized root mean squared residual (SRMR) and the root mean square error of approximation (RMSEA) indicators provided information about the fit of the models with the covariance matrix of the population ( $< 0.08$ ), although this was true only for the first proposed model. The incremental indicators, on the other hand, did not support these data. Further details are provided in Table 5.

**Table 5.** Summary of the tested models

Indicators	Model 1	Model 2	Model 3	Model 4
$\chi^2$	805.65	515.53	515.65	642.50
Df	275	249	249	263
CFI	0.75	0.87	0.87	0.82
TLI	0.73	0.86	0.85	0.80
Log-likelihood	-4912.89	-4533.81	-4703.88	-4831.31
AIC	9925.77	9169.61	9509.77	9786.61
BIC	10134.46	9382.48	9722.63	10045.39
RMSEA	0.06 ( $p < .01$ )	0.05 ( $p = .781$ )	0.05 ( $p = .780$ )	0.05 ( $p = .069$ )
90% CI	[.06, .07]	[.04, .05]	[.04, .05]	[.05, .06]
SRMR	0.05	0.06	0.06	0.05
GFI	0.87	0.92	0.92	0.90
ECVI	1.89	1.29	1.29	1.60

*Internal consistency analysis*

Cronbach's Alpha was used for internal consistency analysis. Specifically, the fidelity of the entire DS-R scale and for each subscale (core disgust subscale, animal-reminder disgust subscale, and contamination-based disgust subscale) was measured. Accordingly, the entire DS-R instrument showed good internal consistency ( $\alpha = .83$ , 95% CI [.82, .85]), and the subscales with good internal consistency were core disgust ( $\alpha = .72$ , 95% CI [.68, .75]) and animal-reminder disgust ( $\alpha = .76$ , 95% CI [.74, .79]). In contrast, the contamination-based disgust subscale showed low internal consistency ( $\alpha = .51$ , 95% CI [.49, .66]).

*Convergent, discriminant, and incremental validity*

To test convergent validity, we measured the disgust variable using two scales, namely DS-R and DES. The results showed a very good association ( $r = .75$ ,  $p < .001$ ). To test discriminant validity, we used the disgust variable (DS-R) together with depression ( $r = -.10$ ,  $p = .022$ ), anxiety ( $r = .02$ ,  $p = .676$ ), and perceived stress

( $r = .14, p = .002$ ). The results showed very weak relationships between disgust and depression, and disgust and perceived stress.

Statistical analyses examined the incremental validity of disgust and other emotions in predicting obsessive-compulsive symptoms. In this direction, regression models were proposed in which the criterion chosen was obsessive-compulsive symptoms, and the predictors included in this analysis were (1) disgust; (2) disgust and anxiety; and (3) disgust, anxiety, and perceived stress. For the application of multiple linear regression, the necessary conditions were checked for both dependent and independent variables. The results showed that there were statistically significant relationships between the predictor variables (disgust, anxiety, and perceived stress) and the criterion variable (obsessive-compulsive symptoms). There was also a statistically significant relationship between the predictors. However, the correlation coefficients were low, below 0.30, so there were no collinearity problems. In addition, variables stored in the database that contained data on possible outliers were examined. For the Mahalanobis, Cook, and Standardized DfFit indices, the results did not exceed the values discussed.

For data collected from a sample of 480 participants, a hierarchical regression model was chosen. Thus, for the model with one predictor, we obtained significant results with a weak prediction ( $R = .20, p < .001$ ). When the second predictor was added, the results continued to be significant with a higher prediction ( $R = .36, p < .001$ ). The model with three predictors was no longer statistically significant ( $R = .37, p > .05$ ). The result for the Durbin-Watson statistic of error independence is equal to 2.05, which is not a problem from this point of view. The results obtained for each proposed model are shown in Table 6.

**Table 6.** Results obtained for each prediction model analysed

Model	$R$	$R^2$	$\Delta R^2$	$\Delta F$	$df1, df2$	$p_{\Delta F}$	$B$	$\beta$	$p$
<b>Model 1</b>									
Disgust	.20	.04	.04	19.94	1, 478	< .001	.23	.20	< .001
<b>Model 2</b>									
Disgust	.36	.13	.09	51.30	1, 477	< .001	.23	.19	< .001
Anxiety							.25	.30	< .001
<b>Model 3</b>									
Disgust	.37	.14	.004	2.15	1, 476	.143	.21	.18	< .001
Anxiety							.21	.04	< .001
Stress							.06	.04	.143

Looking at the results obtained for each proposed model, we found the following results: (1) for the first model, which included the disgust variable, the coefficients were statistically significant ( $p < .001$ ); (2) for the second model, which included the disgust and anxiety predictors, the coefficients were statistically

significant ( $p < .001$ ); (3) for the last proposed model, which included the disgust, anxiety and perceived stress predictors, the results were statistically insignificant for the last variable. With regard to collinearity, the VIF and Tolerance values were within the recommended limits, meaning that there were no collinearity problems among predictors. Consequently, the best prediction model for the data collected was the one based on the first two blocks of variables.

In conclusion, consistent with the proposed objectives, the results demonstrated a positive association between the disgust measured on both scales. A lack of relationship between disgust and anxiety, an increased association between depression, perceived stress and anxiety, and disgust and perceived stress were also highlighted. In addition, disgust and anxiety played an important role in the development of obsessive-compulsive symptoms and could be considered predictors. This observation should be used with caution, since the results obtained are of low intensity.

## **Discussion**

The purpose of this paper was to examine the psychometric properties of the Disgust Scale-Revised, Romanian version, on a non-clinical sample, as well as the implications of an item response model. Overall, the results indicated a good fidelity (through internal consistency), the dominance of the tri-factor model of the DS-R instrument in the literature, the fit of the single-factor model of the scale, good convergent and divergent validity concerning the scale's relationships with other variables, and the important role of disgust and anxiety in predicting obsessive-compulsive symptoms.

The first part of the study revealed, through the psychometric analysis of the DS-R instrument, that the entire scale showed good internal consistency, and the subscales with good internal consistency were related to basic and animal-reminder disgust, with the contamination-related disgust subscale showing poor internal consistency. Consistent with previous research (In Kang et al., 2012; Shams et al., 2015; Van Overveld et al., 2011), acceptable internal consistency was determined. Specifically, these researches obtained Cronbach's Alpha coefficients between .77 and .87; of this study, the internal consistency coefficient was equal to  $\alpha = .83$ , and for the subscales, we obtained increased indicators, except for the subscale measuring contamination-related disgust. These results confirmed a good internal consistency in the measurement, beyond the minimum acceptable thresholds for this indicator.

With regard to convergent validity, a very high correlation coefficient was reported between two scales measuring disgust, in particular the DS-R and DES measurement. In addition, in terms of discriminant validity, disgust (measured with the DS-R instrument) showed a lack of association with anxiety and very weak relationships with depression and perceived stress. These findings differed from

those reported by In Kang et al. (2012). In terms of incremental validity, disgust and anxiety, contributed to an increase of approximately 9.00% in predicting obsessive-compulsive symptoms. While this result is significant, it was also weak. Therefore, it is likely that other variables not included in this study may also help predict obsessive-compulsive symptoms.

Item Response Theory analysis revealed acceptable fit indices for the three subscales of the DS-R instrument. All items showed discrimination coefficients between 0.47 and 5.49, with the discrimination index ranging from low to very high. Moreover, Item Response Theory analysis showed an acceptable coverage of the subscales of the DS-R instrument, with minor issues with certain items. As there is currently no literature on this subject in the local literature, the results could not be compared with those obtained in this paper.

The confirmatory factor analysis revealed that the three-factor models tested for the DS-R instrument were the most widely used, but were not sufficiently consistent with the data tested in this study. Furthermore, research conducted by In Kang et al. (2012) revealed the following five-factor version of the DS-R instrument: core disgust-touch, animal-reminder disgust, core disgust-dirt, contamination-based disgust, and social intolerance disgust. Therefore, the study provided evidence for the psychometric properties of the DS-R instrument and its use in the clinical settings for the evaluation of disgust, especially symptoms of specific phobias and obsessive-compulsive disorder. The research data also confirmed that the one-factor scale structure fulfilled most of the requirements regarding statistical indices. However, the study did not examine the scale's stability over time or susceptibility to change for either a clinical sample or for psychologically treated diagnoses. In addition, the socio-cultural characteristics of the population may be an important element in the under-identified disgust structures. The Romanian population has a different socio-cultural context than countries like the Netherlands, Korea, and the United States, which may influence the different construction of disgust sensitivity, a feature also emphasized by In Kang et al. (2012) on the Korean version of the DS-R instrument.

### *Theoretical and practical implications*

From a theoretical perspective, the results of this study are important because they raise questions about the original structure of the DS-R instrument (and the measured construct) between the original samples from the United States and other European countries and the selected sample from Eastern Europe. One possible explanation for the lack of equivalence could be cross-cultural differences in feelings of disgust, a theme that has been widely highlighted in the literature (Preti et al., 2009; Siegrist & Hartmann, 2020).

From an empirical point of view, the findings of this study show that the DS-R may be successfully used for the Romanian population, especially in the clinical domain. Overall, the findings add to the evidence on the cross-cultural validity of this measure, given that various adaptations of the scale in different languages and

across different populations have often retained the same number of items and good psychometric properties. As a result, the translation of the scale into Romanian was generally found to be as psychometrically valid and reliable as the rest of the adaptations found in the literature.

From psychological perspective, the results of the study can help practitioners in evaluation and clinical decision making. This can be done by including forms of disgust associated with fear of contamination in obsessive-compulsive symptoms. In addition, the development of obsessive-compulsive symptoms that include disgust and anxiety as predictors has suggested the possibility of integrating these findings into the prevention or psychological treatment of mental disorders. These arguments have been made in research highlighting that obsessive-compulsive disorder is a disorder with numerous heterogeneous symptoms (Olatunji, Christian, et al., 2019); in particular, obsessions and compulsions may be accompanied by high levels of anxiety (Hjemdal et al., 2010), similar to anxiety disorders (Stein et al., 2010). Understanding distress beyond general irrational belief measures may be improved by stressor specific irrational beliefs (David et al., 2019). Thus, the study may provide a starting point for investigating the underlying mechanisms of obsessive-compulsive symptoms, with a focus on disgust. This could be particularly useful when applied in clinical populations to develop new psychological treatment approaches.

#### *Study limitations and future research directions*

Several limitations that should be considered were noted. Firstly, the study was cross-sectional and variables were measured only once. Therefore, longitudinal studies are essential to infer changes that may occur intra-individually over time. Secondly, data were collected only on the basis of self-report, which tends to exaggerate associations between variables. Thirdly, there was no rigorous selection of participants, as participants were self-selected. Most likely a representative sample would have accurately reflected the characteristics of the population of interest. Instead, the lack of rigorous sampling may limit the generalizability of the study's findings. Fourthly, the study did not include a control group, and participants were part of a nonclinical sample. Therefore, it is difficult to highlight the possibility that the reported associations are relevant to individuals diagnosed with specific phobias or obsessive-compulsive disorder. Finally, we used only a single instrument to measure the selected variables (with the exception of the measure of disgust). Future research could replicate these results using other instruments to measure the included variables.

Future studies may focus on efforts to validate the DS-R instrument in different populations, as it has been done to date in nonclinical samples from Australia, Brazil, Germany, Italy, Japan, Netherlands, Sweden, United States (Olatunji et al., 2009), Iranian clinical sample (Shams et al., 2015), Korean non-clinical sample (In Kang et al., 2012). This way, equivalence of measurements with

those in other countries around the world can be ensured. Other future directions could include creating and testing other models to determine the appropriate factor structure of the scale, as well as using diversity within the samples, i.e., testing on clinical samples diagnosed with specific phobias and obsessive-compulsive disorder. Future studies are also needed to outline the mechanisms of the disgust construct in relation to anxiety and perceived stress in the development of phobia-specific and obsessive-compulsive clinical manifestations. It is important that these future directions can be applied to clinical populations to develop new techniques for effective psychotherapeutic interventions. Given the importance of disgust in clinical disorders, the development of more complex methods that are independent of correlations, as well as further analyses of psychometric quality in the assessment of disgust, are essential to improve our understanding of the role of this emotion in the pathological setting.

### *Conclusions*

In summary, although disgust is associated with the maintenance of anxiety and obsessive-compulsive symptoms, the relationship of this emotion to negative affect and symptoms of mental disorders is not clear enough. Therefore, the study provided evidence to support the psychometric properties of the revised version of the Disgust Scale for a large Romanian sample. Overall, the study demonstrated that this version of the instrument is reliable, valid, and acceptable for use in the field of psychology, especially when the one-factor model is considered. Further refinement of the scale could be beneficial for a more comprehensive development of this assessment instrument in the clinical setting. However, further studies are needed to apply these results in the clinical context and to develop new directions for effective psychological interventions.

### **Author's Note**

**Acknowledgments.** The author thanks Mr. Daniel Puia-Dumitrescu for proofreading the current paper.

### **References**

- Anderson, L. M., Reilly, E. E., Thomas, J. J., Eddy, K. T., Franko, D. L., Hormes, J. M., & Anderson, D. A. (2018). Associations among fear, disgust, and eating pathology in undergraduate men and women. *Appetite, 125*, 445–453. <https://doi.org/10.1016/j.appet.2018.02.017>

- Armstrong, T., & Olatunji, B. O. (2017). Pavlovian disgust conditioning as a model for contamination-based OCD: Evidence from an analogue study. *Behaviour Research and Therapy*, *93*, 78–87. <https://doi.org/10.1016/j.brat.2017.03.009>
- Arrindell, W. A., Mulkens, S., Kok, J., & Vollenbroek, J. (1999). Disgust sensitivity and the sex difference in fears to common indigenous animals. *Behaviour Research and Therapy*, *37*(3), 273–280. [https://doi.org/10.1016/S0005-7967\(98\)00129-6](https://doi.org/10.1016/S0005-7967(98)00129-6)
- Badour, C. L., & Feldner, M. T. (2016). Disgust and imaginal exposure to memories of sexual trauma: Implications for the treatment of posttraumatic stress. *Psychological Trauma*, *8*(3), 267–275. <https://doi.org/10.1037/tra0000079>
- Beck, A. T., Steer, R. A., Ball, R., & Ranieri, W. F. (1996). Comparison of Beck Depression Inventories-IA and-II in psychiatric outpatients. *Journal of Personality Assessment*, *67*(3), 588–597. [https://doi.org/10.1207/s15327752jpa6703\\_13](https://doi.org/10.1207/s15327752jpa6703_13)
- Bianchi, K. N., & Carter, M. M. (2012). An experimental analysis of disgust sensitivity and fear of contagion in Spider and Blood Injection Injury Phobia. *Journal of Anxiety Disorders*, *26*(7), 753–761. <http://dx.doi.org/10.1016/j.janxdis.2012.06.004>
- Brake, C. A., Rojas, S. M., Badour, C. L., Dutton, C. E., & Feldner, M. T. (2017). Self-disgust as a potential mechanism underlying the association between PTSD and suicide risk. *Journal of Anxiety Disorders*, *47*, 1–9. <https://doi.org/dx.doi.org/10.1016/j.janxdis.2017.01.003>
- Brand, J., McKay, D., Wheaton, M. G., & Abramowitz, J. S. (2013). The relationship between obsessive compulsive beliefs and symptoms, anxiety and disgust sensitivity, and Swine Flu fears. *Journal of Obsessive-Compulsive and Related Disorders*, *2*, 200–206. <http://dx.doi.org/10.1016/j.jocrd.2013.01.007>
- Browne, M. W., & Cudeck, R. (1993). Alternative ways of assessing model fit. In K. A. Bollen & J. S. Long (Eds.), *Testing structural equation models* (pp. 136–162). Sage.
- Cavanagh, K., & Davey, G. C. L. (2000). *The development of a measure of individual differences in disgust*. British Psychological Society.
- Cervin, M., & Perrin, S. (2019). Measuring harm avoidance, incompleteness, and disgust in youth with obsessive-compulsive disorder and anxiety disorder. *Journal of Obsessive-Compulsive and Related Disorders*, *22*, 100442. <https://doi.org/10.1016/j.jocrd.2019.100442>
- Chalmers, R. P. (2012). mirt: A multidimensional Item Response Theory package for the R environment. *Journal of Statistical Software*, *48*(6), 1–29.
- Chen, W.-H., & Thissen, D. (1997). Local dependence indexes for item pairs using Item Response Theory. *Journal of Educational and Behavioral Statistics*, *22*(3), 265–289. <https://doi.org/10.3102/10769986022003265>
- Cisler, J. M., Olatunji, B. O., & Lohr, J. M. (2009). Disgust, fear, and the anxiety disorders: A critical review. *Clinical Psychology Review*, *29*(1), 34–46. <https://doi.org/10.1016/j.cpr.2008.09.007>

- Cohen, S., Kamarck, T., & Mermelstein, R. (1983). A global measure of perceived stress. *Journal of Health and Social Behavior*, *24*(4), 385–396. <https://doi.org/10.2307/2136404>
- Costello, A. B., & Osborne, J. W. (2005). Best practices in exploratory factor analysis: Four recommendations for getting the most from your analysis. *Practical Assessment, Research & Evaluation*, *10*(7), 1–9. <https://doi.org/10.7275/jyj1-4868>
- Curtis, V., De Barra, M., & Auger, R. (2011). Disgust as an adaptive system for disease avoidance behaviour. *Transactions of the Royal Society B: Biological Sciences*, *366*(1563), 389–401. <https://doi.org/10.1098/rstb.2010.0117>
- David, D., Schnur, J. B., & Montgomery, G. H. (2019). Preliminary validation of a stressor-specific rational and irrational beliefs scales: The Beliefs Scale (SBS). *Journal of Evidence-Based Psychotherapies*, *19*(2), 15–28. <https://doi.org/10.24193/jebp.2019.2.11>
- de Jong, P. J., & Borg, C. (2020). Disgust sensitivity. In J. S. Abramowitz & S. M. Blakey (Eds.), *Clinical handbook of fear and anxiety: Maintenance processes and treatment mechanisms* (pp. 81–98). American Psychological Association.
- de Jong, P. J., & Merckelbach, H. (1998). Blood-injection-injury phobia and fear of spiders: Domain specific individual differences in disgust sensitivity. *Personality and Individual Differences*, *24*(2), 153–158. [https://doi.org/10.1016/S0191-8869\(97\)00178-5](https://doi.org/10.1016/S0191-8869(97)00178-5)
- Deacon, B., & Olatunji, B. O. (2007). Specificity of disgust sensitivity in the prediction of behavioral avoidance in contamination fear. *Behaviour Research and Therapy*, *45*, 2110–2120. <https://doi.org/10.1016/j.brat.2007.03.008>
- Engelhard, Iris M., Olatunji, B. O., & de Jong, P. J. (2011). Disgust and the development of posttraumatic stress among soldiers deployed to Afghanistan. *Journal of Anxiety Disorders*, *25*(1), 58–63. <https://doi.org/10.1016/j.janxdis.2010.08.003>
- Fan, Q., & Olatunji, B. O. (2013). Individual differences in disgust sensitivity and health-related avoidance: Examination of specific associations. *Personality and Individual Differences*, *55*(5), 454–458. <https://doi.org/10.1016/j.paid.2013.04.007>
- Fergus, T. A., & Valentiner, D. P. (2009). The Disgust Propensity and Sensitivity Scale–Revised: An examination of a reduced-item version. *Journal of Anxiety Disorders*, *23*(5), 703–710. <https://doi.org/10.1016/j.janxdis.2009.02.009>
- Foa, E. B., Huppert, J. D., Leiberg, S., Langner, R., Kichic, R., Hajcak, G., & Salkovskis, P. M. (2002). The Obsessive–Compulsive Inventory: Development and validation of a short version. *Psychological Assessment*, *14*(4), 485–496. <https://doi.org/10.1037//1040-3590.14.4.485>
- Gilchrist, P. T., Vrinceanu, T., Beland, S., Bacon, S. L., & Ditto, B. (2016). Disgust stimuli reduce heart rate but do not contribute to vasovagal symptoms. *Journal of Behavior Therapy and Experimental Psychiatry*, *51*, 116–122. <http://dx.doi.org/10.1016/j.jbtep.2016.01.005>

- Goss-Sampson, M. (2020). *Statistical analysis in JASP: A guide for students* (4th ed.). <https://doi.org/10.6084/m9.figshare.9980744>
- Haidt, J., McCauley, C., & Rozin, P. (1994). Individual differences in sensitivity to disgust: A scale sampling seven domains of disgust elicitors. *Personality and Individual Differences, 16*(5), 701–713. [https://doi.org/10.1016/0191-8869\(94\)90212-7](https://doi.org/10.1016/0191-8869(94)90212-7)
- Haidt, J., Rozin, P., McCauley, C., & Imada, S. (1997). Body, psyche, and culture: Their relationship between disgust and morality. *Psychology and Developing Societies, 9*(1), 107–131. <https://doi.org/10.1177/097133369700900105>
- Hays, R. D., Morales, L. S., & Reise, S. P. (2000). Item Response Theory and health outcomes measurement in the 21st century. *Medical Care, 38*(9 Suppl), II28. <https://doi.org/10.1097/00005650-200009002-00007>
- Hjemdal, O., Vogel, P. A., Solem, S., Hagen, K., & Stiles, T. C. (2010). The relationship between resilience and levels of anxiety, depression, and obsessive–compulsive symptoms in adolescents. *Clinical Psychology and Psychotherapy, 18*(4), 314–321. <https://doi.org/10.1002/cpp.719>
- Hu, L., & Bentler, P. M. (1999). Cutoff criteria for fit indexes in covariance structure analysis: Conventional criteria versus new alternatives. *Structural Equation Modeling, 6*(1), 1–55. <http://dx.doi.org/10.1080/10705519909540118>
- In Kang, J., Kim, S. J., Cho, H. J., Jhung, K., Lee, S. Y., Lee, E., & An, S. K. (2012). Psychometric analysis of the Korean version of the Disgust Scale—Revised. *Comprehensive Psychiatry, 53*(5), 648–655. <https://doi.org/10.1016/j.comppsy.2011.06.005>
- Khairallah, C., Zoghbi, M., Richa, S., & Bou Khalil, R. (2019). Disgust, impulsivity and depressive dimensions in subjects at risk for bulimia nervosa and/or binge eating disorder. *Asian Journal of Psychiatry, 39*, 32–34. <https://doi.org/10.1016/j.ajp.2018.11.019>
- Kleinknecht, R. A., Kleinknecht, E. E., & Thorndike, R. M. (1997). The role of disgust and fear in blood and injection—Related fainting symptoms: A structural equation model. *Behaviour Research and Therapy, 35*(12), 1075–1087. [https://doi.org/10.1016/S0005-7967\(97\)80002-2](https://doi.org/10.1016/S0005-7967(97)80002-2)
- Knowles, K. A., Cox, R. C., Armstrong, T., & Olatunji, B. O. (2018). Cognitive mechanisms of disgust in the development and maintenance of psychopathology: A qualitative review and synthesis. *Clinical Psychology Review, 69*, 30–50. <https://doi.org/10.1016/j.cpr.2018.06.002>
- Knowles, K. A., Tomarken, A. J., & Olatunji, B. O. (2018). Effects of exposure to erotica on disgust: A preliminary test among contamination-fearful individuals. *Journal of Obsessive-Compulsive and Related Disorders, 18*, 54–60. <https://doi.org/10.1016/j.jocrd.2018.06.006>
- Melli, G., Poli, A., Chiorri, C., & Olatunji, B. O. (2019). Is heightened disgust propensity truly a risk factor for contamination-related obsessive-compulsive disorder? *Behavior Therapy, 50*(3), 621–629. <https://doi.org/10.1016/j.beth.2018.10.002>

- Merckelbach, H., Muris, P., de Jong, P. J., & de Jongh, A. (1999). Disgust sensitivity, blood-injection-injury fear, and dental anxiety. *Clinical Psychology and Psychotherapy*, 6, 279–285. [https://doi.org/10.1002/\(SICI\)1099-0879\(199910\)6:4<279::AID-CPP210>3.0.CO;2-R](https://doi.org/10.1002/(SICI)1099-0879(199910)6:4<279::AID-CPP210>3.0.CO;2-R)
- Morizot, J., Ainsworth, A. T., & Reise, S. P. (2007). Toward modern psychometrics: Application of Item Response Theory models in personality research. In H. T. Reis & C. M. Judd (Eds.), *Handbook of research methods in personality* (pp. 407–423). Guilford Press.
- Mulkens, S. A. N., de Jong, P. J., & Merckelbach, H. (1996). Disgust and spider phobia. *Journal of Abnormal Psychology*, 105, 464–468. <http://dx.doi.org/10.1037/0021-843X.105.3.464>
- Muris, P. (2006). The pathogenesis of childhood anxiety disorders: Considerations from a developmental psychopathology perspective. *International Journal of Behavioral Development*, 30(1), 5–11. <https://doi.org/10.1177/0165025406059967>
- Muris, P., Huijding, J., Mayer, B., Leemreis, W., Passchier, S., & Bouwmeester, S. (2009). The effects of verbal disgust-and threat-related information about novel animals on disgust and fear beliefs and avoidance in children. *Journal of Clinical Child & Adolescent Psychology*, 38(4), 551–563. <https://doi.org/10.1080/15374410902976379>
- Novara, C., Boiche, J., Lebrun, C., Macgregor, A., Mateo, Y., & Raffard, S. (2019). Disgust assessment: Factorial structure and psychometric properties of the French version of the Disgust Propensity and Sensibility Scale Revised-12. *PLoS ONE*, 14(1), e0210639. <https://doi.org/10.1371/journal.pone.0210639>
- Olafsson, R. P., Emmelkamp, P. M. G., Ólason, D. Þ., & Kristjánsson, Á. (2020). Disgust and contamination concerns: The mediating role of harm avoidance and incompleteness. *International Journal of Cognitive Therapy*, 13, 251–270. <https://doi.org/10.1007/s41811-020-00076-5>
- Olatunji, B. O. (2020). Linking Pavlovian disgust conditioning and eating disorder symptoms: An analogue study. *Behavior Therapy*, 51(1), 178–189. <https://doi.org/10.1016/j.beth.2019.06.002>
- Olatunji, B. O., Berg, H., Cox, R. C., & Billingsley, A. (2017). The effects of cognitive reappraisal on conditioned disgust in contamination-based OCD: An analogue study. *Journal of Anxiety Disorders*, 51, 86–93. <http://dx.doi.org/10.1016/j.janxdis.2017.06.005>
- Olatunji, B. O., Christian, C., Brosnoff, L., Tolin, D. F., & Levinson, C. A. (2019). What is at the core of OCD? A network analysis of selected obsessive-compulsive symptoms and beliefs. *Journal of Affective Disorders*, 257, 45–54. <https://doi.org/10.1016/j.jad.2019.06.064>
- Olatunji, B. O., Cisler, J. M., Meunier, S., Connolly, K., & Lohr, J. M. (2008). Expectancy bias for fear and disgust and behavioral avoidance in spider fearful individuals. *Cognitive Therapy and Research*, 32(3), 460–469. <https://doi.org/10.1007/s10608-007-9164-8>

- Olatunji, B. O., Cisler, J., McKay, D., & Phillips, M. L. (2010). Is disgust associated with psychopathology? Emerging research in the anxiety disorders. *Psychiatry Research, 175*(1–2), 1–10. <https://doi.org/10.1016/j.psychres.2009.04.007>
- Olatunji, B. O., & Deacon, B. (2008). Specificity of disgust sensitivity in the prediction of fear and disgust responding to a brief spider exposure. *Journal of Anxiety Disorders, 22*(2), 328–336. <https://doi.org/10.1016/j.janxdis.2007.03.007>
- Olatunji, B. O., Ebesutani, C., David, B., Fan, Q., & McGrath, P. B. (2011). Disgust proneness and obsessive-compulsive symptoms in a clinical sample: Structural differentiation. *Journal of Anxiety Disorders, 25*, 932–938. <https://doi.org/10.1016/j.janxdis.2011.05.006>
- Olatunji, B. O., Ebesutani, C., & Kim, E. H. (2015). Examination of a bifactor model of the Three Domains of Disgust Scale: Specificity in relation to obsessive-compulsive symptoms. *Psychological Assessment, 27*(1), 102–113. <https://doi.org/10.1037/pas0000039>
- Olatunji, B. O., Ebesutani, C., Kim, J., Riemann, B. C., & Jacobi, D. M. (2017). Disgust proneness predicts obsessive compulsive disorder symptom severity in a clinical sample of youth: Distinctions from negative affect. *Journal of Affective Disorders, 213*, 118–125. <http://dx.doi.org/10.1016/j.jad.2017.02.017>
- Olatunji, B. O., Kim, J., Cox, R. C., & Ebesutani, C. (2019). Prospective associations between disgust proneness and OCD symptoms: Specificity to excessive washing compulsions. *Journal of Anxiety Disorders, 65*, 34–40. <https://doi.org/10.1016/j.janxdis.2019.05.003>
- Olatunji, B. O., & McKay, D. (2009). *Disgust and its disorders: Theory, assessment, and treatment implications*. American Psychological Association.
- Olatunji, B. O., Moretz, M. W., McKay, D., Bjorklund, F., de Jong, P. J., Haidt, J., Hursti, T. J., Imada, S., Koller, S., Mancini, F., Page, A. C., & Schienle, A. (2009). Confirming the three-factor structure of the Disgust Scale—Revised in eight countries. *Journal of Cross-Cultural Psychology, 40*(2), 234–255. <https://doi.org/10.1177/0022022108328918>
- Olatunji, B. O., & Sawchuk, C. N. (2005). Disgust: Characteristic features, social manifestations, and clinical implications. *Journal of Social and Clinical Psychology, 24*(7), 932–962. <http://dx.doi.org/10.1521/jscp.2005.24.7.932>
- Olatunji, B. O., Sawchuk, C. N., de Jong, P. J., & Lohr, J. M. (2006). The structural relation between disgust sensitivity and blood-injection-injury fears: A cross-cultural comparison of US and Dutch data. *Journal of Behavior Therapy and Experimental Psychiatry, 37*, 16–29. <https://doi.org/10.1016/j.jbtep.2005.09.002>
- Olatunji, B. O., Sawchuk, C. N., de Jong, P. J., & Lohr, J. M. (2007). Disgust sensitivity and anxiety disorder symptoms: Psychometric properties of the Disgust Emotion Scale. *Journal of Psychopathology and Behavioral Assessment, 29*, 115–124. <https://doi.org/10.1007/s10862-006-9027-8>

- Olatunji, B. O., Sawchuk, C. N., Lohr, J. M., & de Jong, P. J. (2004). Disgust domains in the prediction of contamination fear. *Behaviour Research and Therapy*, *42*(1), 93–104. [https://doi.org/10.1016/S0005-7967\(03\)00102-5](https://doi.org/10.1016/S0005-7967(03)00102-5)
- Olatunji, B. O., Tart, C. D., Ciesielski, B. G., McGrath, P. B., & Smits, J. A. J. (2011). Specificity of disgust vulnerability in the distinction and treatment of OCD. *Journal of Psychiatric Research*, *45*(9), 1236–1242. <https://doi.org/10.1016/j.jpsychires.2011.01.018>
- Olatunji, B. O., Williams, N. L., Lohr, J. M., & Sawchuk, C. N. (2005). The structure of disgust: Domain specificity in relation to contamination ideation and excessive washing. *Behaviour Research and Therapy*, *43*(8), 1069–1086. <https://doi.org/10.1016/j.brat.2004.08.002>
- Olatunji, B. O., Williams, N. L., Tolin, D. F., Abramowitz, J. S., Sawchuk, C. N., Lohr, J. M., & Elwood, L. S. (2007). The Disgust Scale: Item analysis, factor structure, and suggestions for refinement. *Psychological Assessment*, *19*(3), 281–297. <https://doi.org/10.1037/1040-3590.19.3.281>
- Poli, A., Melli, G., & Radomsky, A. S. (2019). Different disgust domains specifically relate to mental and contact contamination fear in obsessive–compulsive disorder: Evidence from a path analytic model in an Italian clinical sample. *Behavior Therapy*, *50*(2), 380–394. <https://doi.org/10.1016/j.beth.2018.07.006>
- Popa, M. (2010). *Statistici multivariate aplicate în psihologie*. Polirom.
- Preti, A., De Girolamo, G., Vilagut, G., Alonso, J., De Graaf, R., Bruffaerts, R., Demyttenaere, K., Pinto-Meza, A., Haro, J. M., Morosini, P., & The ESEMeD-WMH Investigators. (2009). The epidemiology of eating disorders in six European countries: Results of the ESEMeD-WMH project. *Journal of Psychiatric Research*, *43*(14), 1125–1132. <https://doi.org/10.1016/j.jpsychires.2009.04.003>
- R Core Team. (2016). *R: A language and environment for statistical computing*. R Foundation for Statistical Computing. <https://www.R-project.org/>
- Rachman, S. (2004). Fear of contamination. *Behaviour Research and Therapy*, *42*(11), 1227–1255. <https://doi.org/10.1016/j.brat.2003.10.009>
- Rozin, P., Fallon, A. E., & Mandell, R. (1984). Family resemblance in attitudes to foods. *Developmental Psychology*, *20*(2), 309–314. <http://dx.doi.org/10.1037/0012-1649.20.2.309>
- Samejima, F. (1997). Graded Response Model. In W.J. Linden & R. K. Hambleton (Eds.), *Handbook of Modern Item Response Theory* (pp. 85–100). Springer.
- Shams, G., Janani, L., Milosevic, I., & Foroughi, E. (2015). Disgust emotion and obsessive compulsive symptoms in an Iranian clinical sample. *Psychology*, *6*(13), 1721–1731. <https://doi.org/10.4236/psych.2015.613168>
- Shapira, N. A., Liu, Y., He, A. G., Bradley, M. M., Lessig, M. C., James, G. A., Stein, D. J., Lang, P. J., & Goodman, W. K. (2003). Brain activation by disgust-inducing pictures in obsessive-compulsive disorder. *Biological Psychiatry*, *54*(7), 751–756. [https://doi.org/10.1016/S0006-3223\(03\)00003-9](https://doi.org/10.1016/S0006-3223(03)00003-9)

- Siegrist, M., & Hartmann, C. (2020). Perceived naturalness, disgust, trust and food neophobia as predictors of cultured meat acceptance in ten countries. *Appetite*, *155*, 104814. <https://doi.org/10.1016/j.appet.2020.104814>
- Skolnick, A. J., & Dzokoto, V. A. (2013). Disgust and contamination: A cross national comparison of Ghana and the United States. *Frontiers in Psychology*, *4*(91), 1–11. <https://doi.org/10.3389/fpsyg.2013.00091>
- Steer, R. A., & Beck, A. T. (1997). Beck Anxiety Inventory. In C. P. Zalaquett & R. J. Wood (Eds.), *Evaluating stress: A book of resources* (pp. 23–40). Scarecrow Education.
- Stein, D. J., Fineberg, N. A., Bienvenu, O. J., Denys, D., Lochner, C., Nestadt, G., Leckman, J. F., Rauch, S. L., & Phillips, K. A. (2010). Should OCD be classified as an anxiety disorder in DSM-V? *Depression & Anxiety*, *27*(6), 495–506. <https://doi.org/10.1002/da.20699>
- Tybur, J. M., Lieberman, D., & Griskevicius, V. (2009). Microbes, mating, and morality: Individual differences in three functional domains of disgust. *Journal of Personality and Social Psychology*, *97*(1), 103–122. <https://doi.org/10.1037/a0015474>
- Van Delft, I., Finkenauer, C., Tybur, J. M., & Lamers-Winkelmann, F. (2016). Disgusted by sexual abuse: Exploring the association between disgust sensitivity and posttraumatic stress symptoms among mothers of sexually abused children. *Journal of Traumatic Stress*, *29*(3), 237–244. <https://doi.org/10.1002/jts.22099>
- Van Overveld, M., de Jong, P. J., & Peters, M. L. (2010). The Disgust Propensity and Sensitivity Scale – Revised: Its predictive value for avoidance behavior. *Personality and Individual Differences*, *49*(7), 706–711. <https://doi.org/10.1016/j.paid.2010.06.008>
- Van Overveld, M., de Jong, P. J., Peters, M. L., & Schouten, E. (2011). The Disgust Scale-R: A valid and reliable index to investigate separate disgust domains? *Personality and Individual Differences*, *51*(3), 325–330. <https://doi.org/10.1016/j.paid.2011.03.023>
- Van Overveld, W. J. M., de Jong, P. J., Peters, M. L., Cavanach, K., & Davey, G. C. L. (2006). Disgust propensity and disgust sensitivity: Separate constructs that are differentially related to specific fears. *Personality and Individual Differences*, *41*, 1241–1252. <https://doi.org/doi:10.1016/j.paid.2006.04.021>
- Wood, N. D., Akloubou Gnonhosou, D. C., & Bowling, J. (2015). Combining parallel and exploratory factor analysis in identifying relationship scales in secondary data. *Marriage & Family Review*, *51*(5), 385–395. <https://doi.org/10.1080/01494929.2015.1059785>
- Woody, S. R., & Tolin, D. F. (2002). The relationship between disgust sensitivity and avoidant behavior: Studies of clinical and nonclinical samples. *Journal of Anxiety Disorders*, *16*, 543–559. [https://doi.org/10.1016/S0887-6185\(02\)00173-1](https://doi.org/10.1016/S0887-6185(02)00173-1)

## INSTRUCTIONS TO AUTHORS

### *Manuscript preparation.*

Manuscripts should not exceed 50 pages, must be prepared according to the *Publication Manual of the American Psychological Association*, 7<sup>th</sup> edition, and must be typed double-spaced throughout including the cover sheet, abstract and keywords, text, references, and tables/figures. Articles should be written in English. All articles should include an English abstract of no more than 250 words. Manuscripts are submitted for blind review; therefore, the author's name, degree, and affiliation should appear on the cover sheet only, which should also include the article title and the complete mailing address and telephone number of the corresponding author.

### *Submitting the manuscript.*

Manuscripts can be currently submitted using the Journal's electronic submission system, using: <https://www.ejmanager.com/my/jebp/>. The corresponding author will receive a confirmation e-mail once a manuscript number has been assigned. For manuscript-related inquiries, please also contact the Editor ([jebp@psychology.ro](mailto:jebp@psychology.ro)).

The corresponding author should provide a cover letter confirming that the manuscript is not being concurrently reviewed by another journal together with an anti-plagiarism declaration stating that the paper they are submitting does not contain any plagiarized content. The opinions and statements do not necessarily represent the policies of IIAS of PAMH or the views of the editor. By submitting a manuscript, the authors agree that the copyright for their article is transferred to the IIAS of PAMH, if and when the article is accepted for publication.

### *Subscriptions.*

Starting with volume XXIII (2023), JEBP has become a Platinum Open Access journal which allows immediate access to the content of the journal without the payment of a subscription fee or licence. Authors pay no article publication charge and all the costs of publishing the journal are met by one or more sponsoring organizations.

We acknowledge the support of Babeş-Bolyai University Program for Research, Competitiveness and Excellence, and CNFIS-FDI-2022-0179 Project.

ARTICLES SECTION

- Temporal Dynamics of Stress, Affect, and Abdominal Pain in IBS: Insights from a Clinical Sample..... 1**  
 SANDA PLETIKOSIĆ TONČIĆ, MARKO TONČIĆ, TAJANA JANČEC
- Evaluation of a Schema Therapy-Based Prevention Group Program for Children and Their Parents ..... 23**  
 ROZA LAIOUS, EVANGELIA P. GALANAKI, AIKATERINI AGGELI, CHARA TZAVARA, EFTYCHIA ARGALIA, DARIA BAKOURINI, VASSILIKI KOUTRAFOURI, AIKATERINI MARINI, AND IOANNA SINTILA
- Psychometric Properties of the Italian Version of the Interpersonal Sensitivity Measure (IPSM) ..... 53**  
 COMPARE LISA, CANSU ALSANCAK-AKBULUT, GIOVANNI TUMMINARO, MARTINA SMORTI, OLIVIA BERNINI, FRANCESCA RAVAGLI, CARMEN BERROCAL MONTIEL
- The Effectiveness of Compassionate Mind Training (CMT) for Undergraduate Students..... 69**  
 TÜNDE PÓKA AND ANDREA BARTA
- Impaired Emotional Processing in Major Depressive Disorder. Accuracy versus Processing Speed ..... 105**  
 BOGDAN NEMEŞ, HORIA G. COMAN, DANA C. HERŢA, RALUCA N. TRIFU, DOINA M. C. COZMAN
- Loneliness and Cognitive Vulnerability Factors: A Systematic Review Focused on Maladaptive Cognitions ..... 117**  
 LIA-ECATERINA OLTEAN, MIRUNA-GABRIELA CANACHE, ANDREI PATRICHI, RALUCA IOANA RÎMBU, DARIA SÎNTOMA, ANDREI C. MIU, AURORA SZENTÁGOTAI-TÁTAR
- Adaptation and Validation of the Meteoropathy Questionnaire to the Turkish Sample ..... 139**  
 CENNET YASTIBAŞ-KAÇAR, İMRAN GÖKÇEN YILMAZ-KARAMAN, MARIANNA MAZZA
- Loneliness And Mental Health During the First Covid-19 Lockdown in Romania..... 155**  
 A. HOPULELE-PETRI, S.A. MATU, O. CAPATINA, M. MANEA
- Potential Mechanisms Underlying Reappraisal Strategies: An Exploratory Study.. 177**  
 KAROL J. WILD, BIANCA MACAVEI, ADRIAN N. OPRE
- Psychometric Properties and Factor Structure of the Disgust Scale-Revised (DS-R) for the Romanian population..... 201**  
 SIMONA A. PASCAL

The abstracts of the articles are available online on the website of the Journal of Evidence-Based Psychotherapies <http://jebp.psychotherapy.ro/>  
 International Institute for the Advanced Studies of Psychotherapy and Applied Mental Health (IIAS of PAMH) <http://www.psychotherapy.ro>

